

**September 30, 2021**

**Applicant(s):** Mark D. Larkin, Jr.  
Inkworks, Inc., T/a Coppermine  
5602 Cottonworth Avenue k/a 5731 Cottonworth Avenue 21209

**Class:** "BD7" Beer, Wine & Liquor License

Application to transfer ownership and location of a Class "BD7" BWL License presently located at 5736 Falls Road to 5602 Cottonworth Avenue k/a 5731 Cottonworth Avenue.

(a) **Applicant(s) Information:** (1) Mark D. Larkin, Jr. was born in Baltimore, MD in January of 1989. He lives in Baltimore, MD.

(b) **Ownership Breakdown:** (1) Mark D. Larkin, Jr. (100%).

(c) **Purchase Price of Business:** The purchase price of the business is \$35,000. Deposit of \$10,000 was made. Remaining balance to be paid at settlement.

(d) **Qualified Voters:** Carson Dach, Gregory Rogers and Paul Gochar are qualified Baltimore City voters.

(e) **Zoning:** Applicant has applied for a USE permit, for the use of the property as a recreational facility adding accessory restaurant/snack bar.

(f) **Corporate Standing:** Inkworks, Inc. is a MD Corporation and as of 9/2/2021 is active and in good standing.

(g) **Posting Report:** The location was posted on 9/1/2021, and checked on 9/10/2021. This meets the 10-day rule. There is 1 licensed liquor establishment(s) in the 2x2 area "A" BWL-1.

(h) **Timeline:** Last Inspection by BLLC was performed 3/11/2020. At that time, the establishment was open and operating. According to the licensee the establishment was permanently closed due to the pandemic. On 3/12/2020, the Governor issued an Executive Order that extended timelines under Alc. Bev. Article 12-2202. License is valid.

(j) **Letters of Support/Opposition:** At this time the Board has no letter(s) of opposition or support.

In considering this request, under the provisions of Alcoholic Beverages Article 4-210(A) the Board must consider the following factors: 1. The public need and desire for the license; 2. The number and location of existing license holders; 3. The potential effect on existing license holders of the license for which application is made; 4. The potential commonality or uniqueness of the services and products to be offered by the business of the applicant; 5. The impact of the license for which application is made on the health, safety, and welfare of the community, including issues relating to crime, traffic conditions, parking, or convenience; and 6. Any other factor that the local licensing Board considers necessary.

**Board's Decision:**

2020 Application for Alcoholic Beverages License Board of Liquor License Commissioners for Baltimore City

NEW/TRANSFER/EXPANSION/AMENDMENT(S) APPLICATION FEE - \$600.00

INDICATE TYPE OF LICENSE APPLICATION: TRANSFER  NEW  EXPANSION OF PREMISES  AMENDMENT(S)

EXPLANATION OF REQUEST: Transfer of ownership and location CLASS TYPE: BD7

*Please select one option and fill out the requested information*

A) NEW LICENSE REQUEST: ADDRESS OF PROPOSED LOCATION: N/A

B) TRANSFER OF OWNERSHIP ONLY: ADDRESS OF CURRENT LICENSE: N/A

C) TRANSFER OF OWNERSHIP AND LOCATION: CURRENT ADDRESS OF LICENSED LOCATION: 5736 Falls Road  
 TRANSFER OF OWNERSHIP AND LOCATION: ADDRESS OF PROPOSED RELOCATION: 5602 Cottonworth Avenue

D) AMENDMENT OR EXPANSION REQUEST: ADDRESS OF THE LOCATION: N/A 5412

CORPORATE/LLC/LLP/PARTNERSHIP NAME: Inkworks, Inc. TRADE NAME: Coppermine

BUSINESS PHONE NUMBER: 410-337-7701 BUSINESS EMAIL ADDRESS: mark@gocoppermine.com

ATTORNEY FOR THE APPLICANT: Stephan W. Fogleman Esq ADDRESS: 1720 Thames St #300 Baltimore MD 21231 PHONE: 410-258-8500

Part of Premises Used (Note: Floors and Areas for Storage): 1st floor bus and storage Outdoor Table Service Provided?  Yes  No Delivery of alcohol?  Yes  No  
 Live Entertainment provided?  Yes  No What Kind (Ex. D.J. Band, Etc.)? \_\_\_\_\_ Off Premise Catering of Food and Alcohol?  Yes  No  
 Zoning Receipt or Current Certificate of Occupancy Permit attached to Application?  Yes  No Estimated Seating Capacity: 135

*Please note that as per Alc. Bev. Art. 5-12-1407(A)(2), an application for the issuance or transfer, is not complete unless the applicant has obtained approval and/or verification from the Baltimore Municipal Zoning Appeals (BMZA)*

1. Applicant A

Mark D. Larkin, Jr. \_\_\_\_\_  
 (Full name) \_\_\_\_\_ (Telephone no.) \_\_\_\_\_ E-mail (Required) \_\_\_\_\_  
844 S. Kenwood Avenue Baltimore MD 21224 6 years  
 (Residence) Street City State Zip Code (period of residency in Baltimore City)  
1/89 M Baltimore County MD  
 (Month/Year of Birth) (Sex: Male or Female) (Place of Birth)  
 Check:  Yes  No Are you currently a resident of the City of Baltimore?

2. Applicant B

\_\_\_\_\_  
 (Full name) \_\_\_\_\_ (Telephone no.) \_\_\_\_\_ E-mail (Required) \_\_\_\_\_  
 \_\_\_\_\_  
 (Residence) Street City State Zip Code (period of residency in Baltimore City)  
 \_\_\_\_\_  
 (Month/Year of Birth) (Sex: Male or Female) (Place of Birth)  
 Check:  Yes  No Are you currently a resident of the City of Baltimore?

3. Applicant C

\_\_\_\_\_  
 (Full name) \_\_\_\_\_ (Telephone no.) \_\_\_\_\_ E-mail (Required) \_\_\_\_\_  
 \_\_\_\_\_  
 (Residence) Street City State Zip Code (period of residency in Baltimore City)  
 \_\_\_\_\_  
 (Month/Year of Birth) (Sex: Male or Female) (Place of Birth)  
 Check:  Yes  No Are you currently a resident of the City of Baltimore?

1. Has the applicant(s) been adjudged guilty of a felony in the State of Maryland or any other?  Yes  No - If yes, indicate applicant and explain.

Applicant A  B  C

2. Has the applicant(s) been adjudged guilty of violating the laws governing the sale of any alcoholic beverage or for gambling in any State, including Maryland?  Yes  No - If yes, mark applicant and provide explanation in adjacent space provided.

Applicant A  B  C

3. State whether the applicant(s) has ever been adjudged guilty of any offense against the laws of the State of Maryland, any other State within the United States, or against the United States (Federal Crime)?  Yes  No - If yes, mark applicant and explain.

Applicant A  B  C

4. Has the applicant(s) ever had a license for the sale of alcoholic beverages in the State of Maryland?  Yes  No If yes, mark applicant and explain (address of location, dates that the applicant was a licensee, and the trade name).

Applicant A  B  C

5. Has the applicant(s) ever had a liquor license suspended or revoked?  Yes  No If yes, mark applicant and explain.

Applicant A  B  C

6. Does the applicant(s) have a financial interest in any other alcoholic beverage business or business for which an alcoholic beverage license has been applied for, granted, and issued?  Yes  No If yes, mark applicant and explain (address of location and trade name).

Applicant A  B  C

7. Do the spouses or dependent children of any of the applicant(s) have a financial interest in any other alcoholic beverages license or business in Baltimore City or any other jurisdiction in the State of Maryland?  Yes  No If yes, mark applicant and explain (address of location and trade name).

Applicant A  B  C

8. Are you financially interested in any other alcoholic beverages license applied, granted or issued?  Yes  No If yes, please explain.

Applicant A  B  C

9. Is the licensed premise currently open and operating?  Yes  No If no, then provide date of last day of operation of the establishment.

9/31/20

10. Do any of the applicant(s) - personally or through an entity - have any indebtedness or other financial obligations to any manufacturer, brewer, distiller, or wholesaler at the time of making this application?  Yes  No If yes, please explain. If yes, please provide information as to the applicant(s) indebted - personally or through an entity - the amount of the indebtedness, and the name of the manufacturer, brewer, distiller, or wholesaler?

Applicant A  B  C

11. Please list the following information for the Manager of the establishment to be licensed:

Name	Address	Phone	Email
Mark Larkin Jr	844 S kenwood ave	[REDACTED]	[REDACTED]

Applicants Applying as Business Entities - (Give name(s) and addresses - in Corporation list all officers (attach list if necessary) or in Limited Liability Company/Partnerships list all authorized persons.) *Please note that all licensees MUST have a FINANCIAL INTEREST in the license applied for as per Alc. Bev. Art. 8-4-109 (a)(11). If necessary, please attach a list of the names and address of all outstanding stock holders who at the time of application own any stock of the corporation and the articles of incorporation, partnership agreement or articles of organization.*

- 1) NAME: Mark Larkin Jr ADDRESS: 844 S Kenwood Ave TITLE: Pres. %OF STOCK HELD: 100
- 2) NAME: \_\_\_\_\_ ADDRESS: \_\_\_\_\_ TITLE: \_\_\_\_\_ %OF STOCK HELD: \_\_\_\_\_
- 3) NAME: \_\_\_\_\_ ADDRESS: \_\_\_\_\_ TITLE: \_\_\_\_\_ %OF STOCK HELD: \_\_\_\_\_
- 4) NAME: \_\_\_\_\_ ADDRESS: \_\_\_\_\_ TITLE: \_\_\_\_\_ %OF STOCK HELD: \_\_\_\_\_

*\*Extract from Law: If any affidavit or oath required under the provisions of this Act shall contain any false statements, the offender shall be deemed guilty of perjury. And upon indictment and conviction thereof, shall be subject to penalties provided by Law for that crime.*

CERTIFICATE OF APPLICANTS: At least one applicant whose signature appears below certifies that he/she is a current resident of Baltimore City, Maryland at the time of filing of this application. Each of said applicants hereby certifies further that if the license applied for is granted, he/she will conform to all State and County laws and regulations relating to the sale of alcoholic beverages, as well as to the rules and regulations of the Board of License Commissioners for Baltimore City, and hereby grants permission to the State Comptroller, his duly authorized deputies, inspectors and clerks, The Board of License Commissioners for Baltimore City, its duly authorized agents and employees, and any peace officer of Baltimore City or the State of Maryland to inspect and search at any and all hours, without warrant, the premises and any and all parts thereof upon and in which said business is to be conducted. If license is issued, the applicants must ensure that at least one licensee remains a resident of Baltimore City throughout the duration of this license.

[Signature]  
Signature of Applicant A

I hereby certify that on the 21 day of April, 2021, before me, the subscriber, a notary public of the State of Maryland in and for Baltimore City, personally appeared Mark Larkin Jr. the applicant(s) named in this application made oath in due form of law that the matter and facts contained in said application are true and correct. As witness, my hand and notarial seal.

Signature: [Signature] (Notary Seal) My Commission expires \_\_\_\_\_  
 Printed Name: Stephen W Fogelman Jr.  
 STEPHAN W. FOGLEMAN, JR.  
 NOTARY PUBLIC STATE OF MARYLAND  
 My Commission Expires \_\_\_\_\_

Signature of Applicant B

I hereby certify that on the \_\_\_\_\_ day of \_\_\_\_\_, 20\_\_\_\_, before me, the subscriber, a notary public of the State of \_\_\_\_\_ in and for \_\_\_\_\_, personally appeared \_\_\_\_\_ the applicant(s) named in this application made oath in due form of law that the matter and facts contained in said application are true and correct. As witness, my hand and notarial seal.

Signature: \_\_\_\_\_ (Notary Seal) My Commission expires \_\_\_\_\_

Printed Name: \_\_\_\_\_

Signature of Applicant C

I hereby certify that on the \_\_\_\_\_ day of \_\_\_\_\_, 20\_\_\_\_, before me, the subscriber, a notary public of the State of \_\_\_\_\_ in and for \_\_\_\_\_, personally appeared \_\_\_\_\_ the applicant(s) named in this application made oath in due form of law that the matter and facts contained in said application are true and correct. As witness, my hand and notarial seal.

Signature: \_\_\_\_\_ (Notary Seal) My Commission expires \_\_\_\_\_

Printed Name: \_\_\_\_\_

Alex Jacobs 13100 Beaver Dam RD 21020

Name and Address of the owners of the premise/landlord: Northwest Partners LLC Phone Number: 

**STATEMENT OF OWNER OF PREMISES REQUIRED IN CONNECTION WITH ALCOHOLIC BEVERAGES LAW OF MARYLAND**

(I, WE) Alex Jacobs HEREBY CERTIFY, That (I am, we are) the owner(s) of the property located at 5731 Cottonworth Ave 21209, Baltimore, City with a Zip Code of 21209, which is named in the present application made to the Board of Liquor License Commissioners of Baltimore City under the Alcoholic Beverage Laws of Maryland and assent to the granting of the license applied for, and hereby authorize the State Comptroller, his duly authorized deputies, inspectors and clerks, the Board of Liquor License Commissioners of Baltimore City, its duly authorized agents and employees, and any peace officer of the City of Baltimore and State of Maryland, to inspect and search, without warrant, the premises upon which the business is to be conducted, and any and all parts of the building in which said business is to be conducted, at any and all hours.

  
Signature of Owner of the Property

I hereby certify that on the 29 day of March, 2021, before me, the subscriber, a notary public of the State of Maryland, in and for Baltimore City personally appeared Alex Jacobs the landlord/property owner named in this application made oath in due form of law that the matter and facts contained in said application are true and correct.



As witness, my hand and notarial seal

Notary Signature:   
Notary Printed Name: Stephan W Fugleman Jr

(Notary Seal) My Commission expires 12/16/22  
STEPHAN W. FUGLEMAN, JR.  
NOTARY PUBLIC STATE OF MARYLAND  
My Commission Expires 12/16/22

The following certificates must be signed by at least 3 persons.

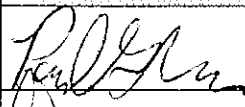
We, the undersigned citizens, real estate owners and registered voters in the City of Baltimore in which the business covered by the present application is to be conducted. We certify that the qualifying applicant(s) is/are personally known to us and is a resident of Baltimore City and a resident of the State of Maryland at the time of this application.

Names	Address	Signature	DOB (Month/Year)	Length of time Acquainted with the Applicant(s)
Paul Gochar	2363 Boston St. 21224		07/1975	12 years
Carson Dach	1115 Baylis St Baltimore 21204		9/1980	8 years
Grea Rogers	904 S Linwood Pl BA Home, MD 21224		9/1970	8 years

RECEIVED

2021  
Baltimore City  
Liquor Board

RECEIVED

APR 30 2021

RECEIVED

APR 30 2021

Board of Liquor License Commissioners for the City of Baltimore  
14 North Charles Street, Suite 100, Baltimore, Maryland 21201  
Phone: 410-396-4377 Fax: 410-396-4382

Please note that this is a public document and upon request will be provided to the general members of the public.

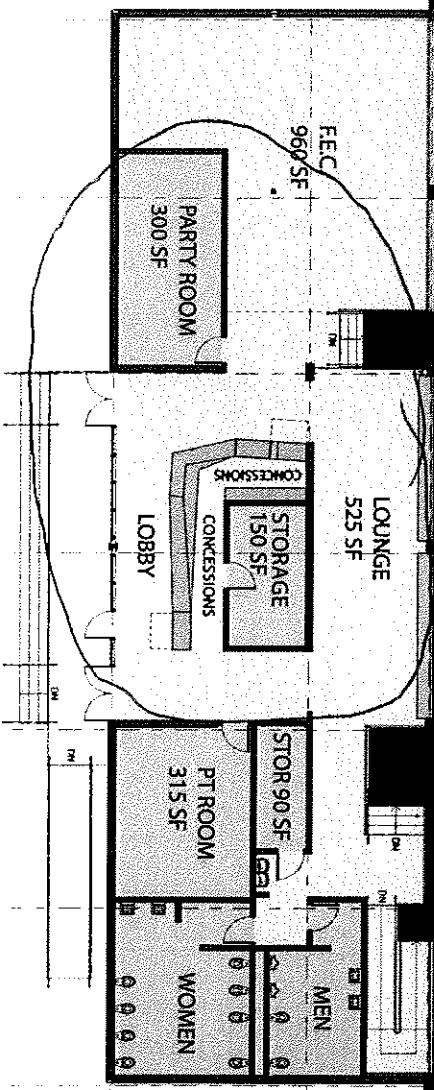
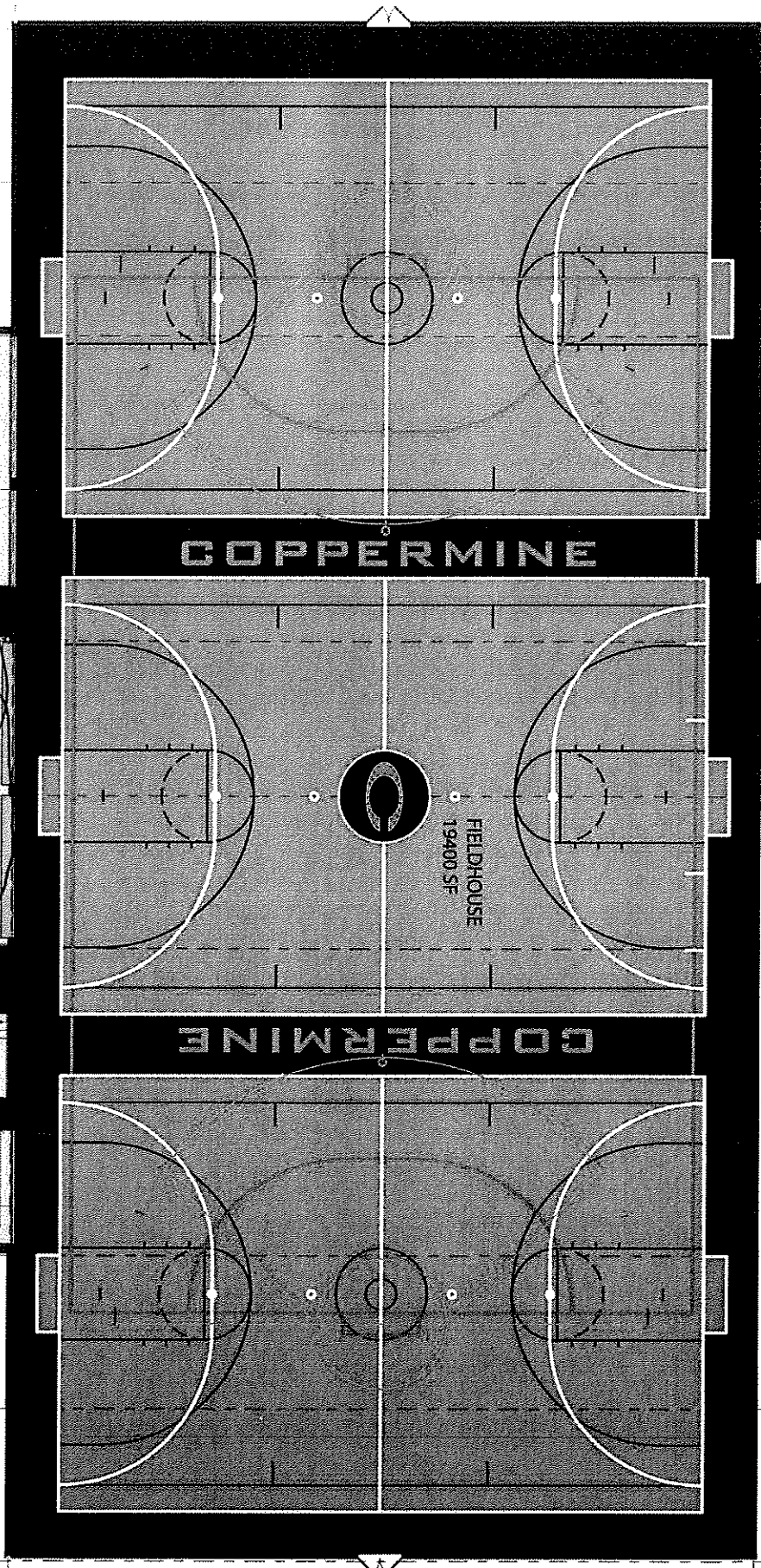



## Liquor Board System

Version 1.0

Annual-Renewal ▾ | License-Transfer ▾ | One-Day ▾ | Add New License ▾ | Query ▾

### License Detail

#### License Info

License Num: **LBD7 301**      Cert Num: **0832**      Fee: **\$1,320.00**      Status: **Renewed**  
 License Date: 5/1/2021      License Year: 2021  
 CR Number: 16536009  
 Payment Date: 09-14-21

2020 - 2021 TPP Paid   
 2021 Trader's License

### Add Adult Entertainment License

#### Location

Corp Name: **CURB SHOPPE, LLC**  
 Trade Name: **CURB SHOPPE**  
 Zone Code: 48  
 Phone: 410-433-8299

Block Num: 5736      Street: FALLS ROAD  
 City: BALTIMORE      State: MD      Zip: 21209

CR Number: 16536009

Portion of Business Used:  
 FIRST FLOOR FRONT OF ONE STORY BUILDING FOR BUSINESS

Restriction:  
 NO CURB SERVICE PERMITTED. NO CONSUMPTION OF ALCOHOLIC BEVERAGES  
 PERMITTED IN AUTOMOBILES. NO LIVE ENTERTAINMENT, LIVE MUSIC OR DANCING. NO   
 SEPARATE PACKAGE GOODS STORE OR DEPARTMENT TO BE CREATED. ALL PACKAGE   
 GOODS SALES TO BE MADE OVER THE BAR.

#### License Owners

First Name	Last Name	Street	City	State	Zip	Action	Change Owner
JAMES	LITTLE	1107 HARRITON ROAD	BALTIMORE	MD	21210	<input type="button" value="Edit"/>	<input type="button" value="Remove Owner"/>

**Comments**

Date	Comment	Action
05/07/2021	Application for transfer of ownership and location of a class "BD7" BWL License presently located at 5736 Falls Road to 5731 Cottonworth Avenue filed on behalf of Inkworks, Inc. T/a Coppermine, Mark D. Larkin, Jr. on 4/30/2021 /kk	Delete
11/21/2019	Submitted 2019 Trader's License..../sb	Delete
10/30/2019	Personal Property Tax Owed to City of Baltimore was cleared as per the email received from Law Department on October 29, 2019..../mb.	Delete
09/26/2019	***PERSONAL PROPERTY TAX OWED TO CITY OF BALTIMORE Letter sent to Licensee/s Home Address on September 26, 2019.*** /mb	Delete
12/13/2018	Personal Property Tax Owed to City of Baltimore was cleared on December 13, 2018..../mb.	Delete
11/23/2018	Personal Property tax letter mailed to Licensee(s) Home Address on 11/19/18../mb	Delete
05/10/2018	STATE OF MD TAX HOLD RELEASED..../mb	Delete
01/30/2018	****STATE OF MD TAX HOLD, letter sent to Licensee on January 30, 2018.****/mb	Delete
12/29/2016	Alcohol Awareness expires on 12/02/20 (Thomas W. Hawkins, Brandon Harris, Mellissa Russell & Courtney Pelletier).... /sb	Delete
11/18/2016	11/17/16- Public Hearing re: Application to transfer ownership- APPROVED (3-0 vote)	Delete
11/14/2016	State of MD Tax RELEASE , letter sent on 11/10/2016 CR#0699832-transfer .....k/r	Delete
04/22/2016	Given Annual License to Chief Inspector, M.Fosler for delivery to establishment.... /sb	Delete
02/08/2016	Alcohol Awareness expires 02/03/2020 (Paul F. Schiffbauer) John S Murray	Delete
02/08/2016	Alcohol Awareness expires 02/03/2020 (Steven R. Beadle) John S Murray	Delete
03/01/2004	7/23/91 Police arrested disorderly person outside establishment i CC 5G-56756	Delete

Print History (Print Card)

License num: LBD7 301

Address: 5736 FALLS ROAD

Trade Name: CURB SHOPPE

Comment:

Add Comment

**Hold Info**





## INKWORKS INC.: D12960985

**Department ID Number:**

D12960985

**Business Name:**

INKWORKS INC.

**Principal Office:** 

13100 BEAVER DAM ROAD  
HUNT VALLEY MD 21030

**Resident Agent:** 

ALEXANDER JACOBS  
13100 BEAVER DAM ROAD  
HUNT VALLEY MD 21030

**Status:**

INCORPORATED

**Good Standing:**

THIS BUSINESS IS IN GOOD STANDING

**Business Type:**

CORPORATION

**Business Code:**

03 ORDINARY BUSINESS - STOCK

**Date of Formation/ Registration:**

01/30/2009

**State of Formation:**

MD

**Stock Status:**

STOCK

**Close Status:**

NO

PROPOSED LOCATION: 5602 Co-Henrieville Ave

### MAP SUMMARY (RECAPITULATION)

TOTAL ESTABLISHMENTS IN MAP AREA 1

"A" BEER & WINE \_\_\_\_\_

"B" BEER & WINE \_\_\_\_\_

"C" BEER & WINE \_\_\_\_\_

"D" BEER & WINE \_\_\_\_\_

"A" BEER, WINE & LIQUOR 1

"A-2" BEER, WINE & LIQUOR \_\_\_\_\_

"B" BEER, WINE & LIQUOR \_\_\_\_\_

"C" BEER, WINE & LIQUOR \_\_\_\_\_

"D" BEER, WINE & LIQUOR \_\_\_\_\_

"ED7" BEER, WINE & LIQUOR \_\_\_\_\_

ARENA \_\_\_\_\_

HOTEL/MOTEL \_\_\_\_\_

RACING \_\_\_\_\_

PREPARED BY: Darryl Clark DATE: 9/2/21

# 5602 Cottonworth Ave

Liquor Licensed establishments

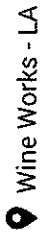

Wine Works - LA



5602 Cottonworth Ave

Transfer of ownership and location

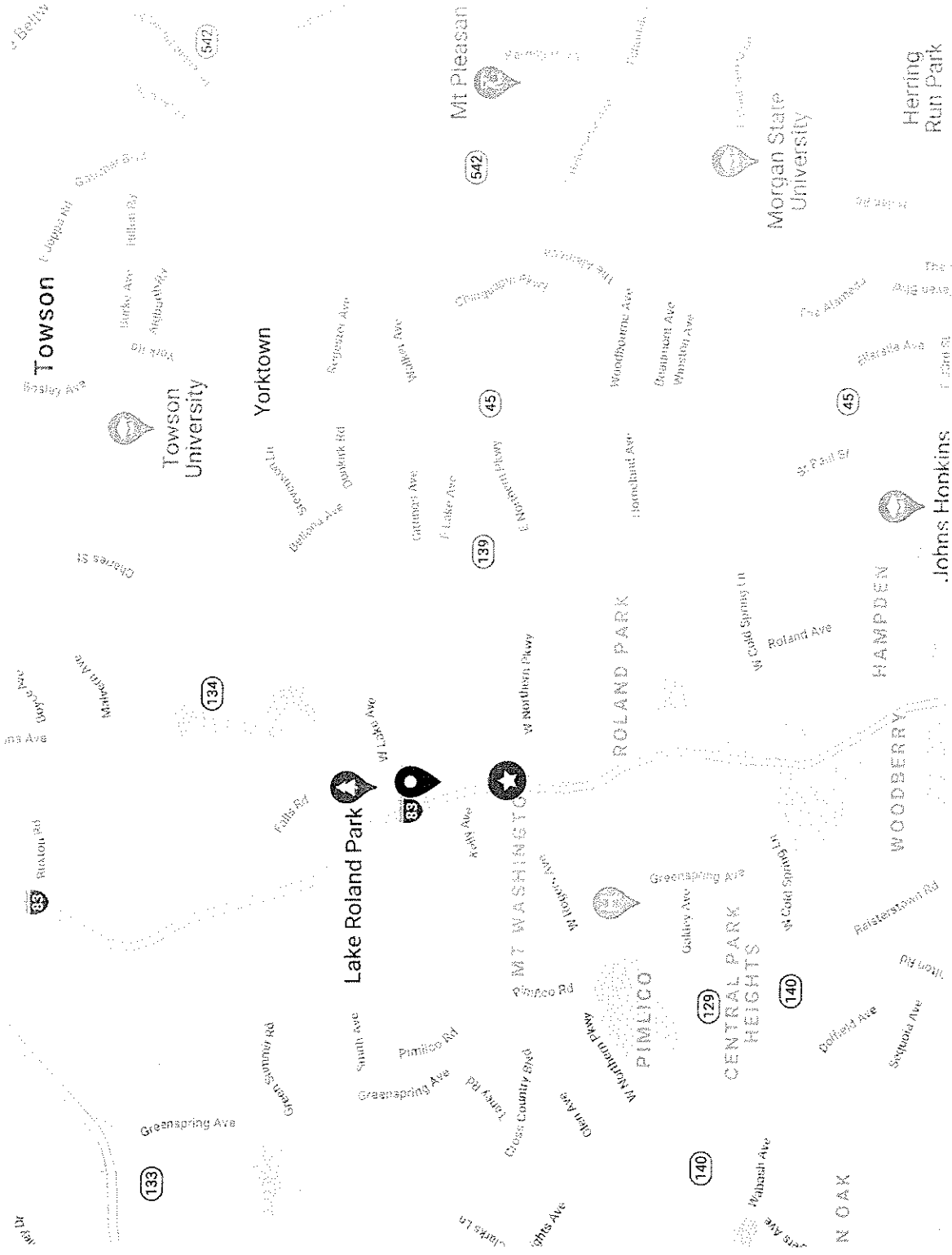

### Board of Liquor License Commissioners

For Baltimore City  
1 North Charles Street, 15th Floor  
Baltimore, Maryland, 21201

## INSPECTORS REPORT - TRANSFERS/NEW APPLICATIONS

Licensee Information (Trade Name):	<input type="text" value="Coppermine"/>
Corporation Name:	<input type="text" value="Inkworks, Inc"/>
Location Address:	<input type="text" value="5731 Cottonworth Ave"/>
License Type:	Class "BD7" Beer, Wine and Liquor <input type="button" value="v"/>
Is the establishment open and operating in a safe and sanitary manner? (If not open, not in comments - CLOSED or NOT OPERATING)	No <input type="button" value="v"/>
Is the location within 300 feet of Church and/or School?	No <input type="button" value="v"/>
Date Posted?	<input type="text" value="9/1/2021"/> <input type="button" value="calendar"/>
Estimated Date of Removal?	<input type="text" value="9/10/2021"/> <input type="button" value="calendar"/>
Are there any other licensed establishments within a two block radius?	Yes <input type="button" value="v"/>

*Other licensed locations - Describe/Note:*

Please see map for additional locations of Liquor Licensed establishment

*Comments and Follow-up Items(s) (please note any issues or concerns about the location):*

Filed application for the transfer of ownership and location  
From 5736 Falls road to 5731 Cottonworth Ave  
Not operating as of yet

*Insert Photo of Sign and location:*

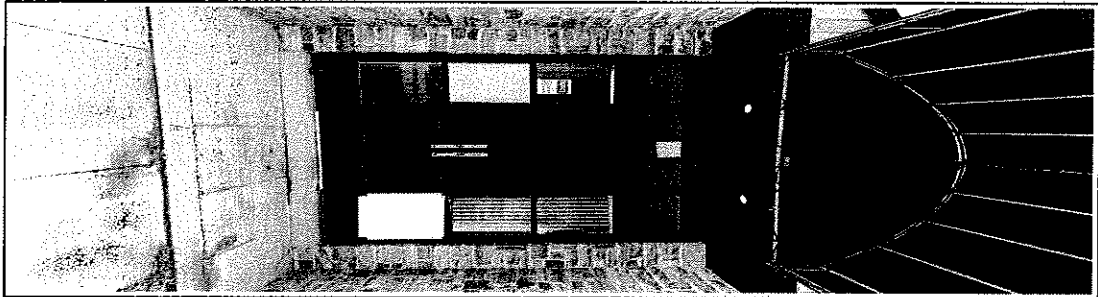

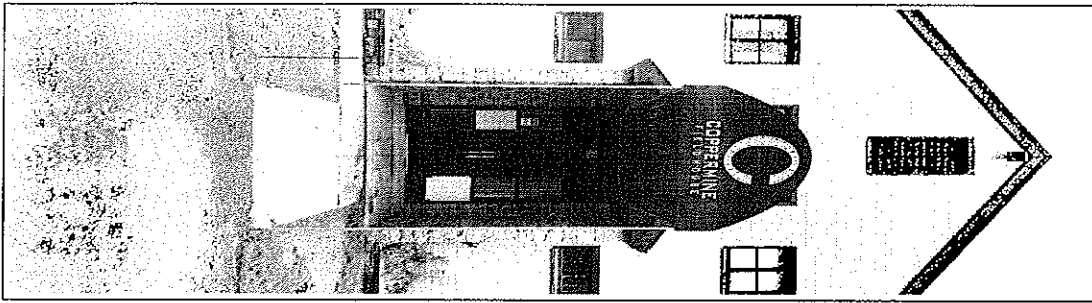

Attach Additional Photos

Inspector Name		Date and Time	
<input type="text" value="i:\0#.w\baltimore\darryl.clark"/>		<input type="text" value="5/25/2021"/>	<input type="text" value="1:57:20 PM"/>
Name of Licensee (if present)			
<input type="text"/>			
Approve		Disapprove	

**Board of Liquor License Commissioners**  
For Baltimore City  
1 North Charles Street, 15th Floor  
Baltimore, Maryland, 21201

**POSTING SIGNS REPORT**

*Applicant(s) Name:*

*Address of Premises:*

*Inspector:*

*Date Posted:*

*Time Posted:*

*Date Rechecked:*

*Time Rechecked:*

*Manager or Owner when sign posted:*

*Summary on location of sign posted:*

Sign is posted on front window

*Summary on location of sign rechecked:*

Sign is still posted on the front window of the establishment

*Insert Photo of Sign and location:*

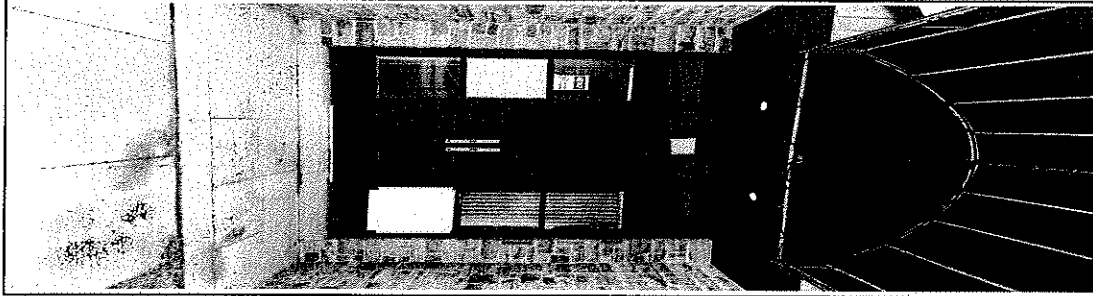

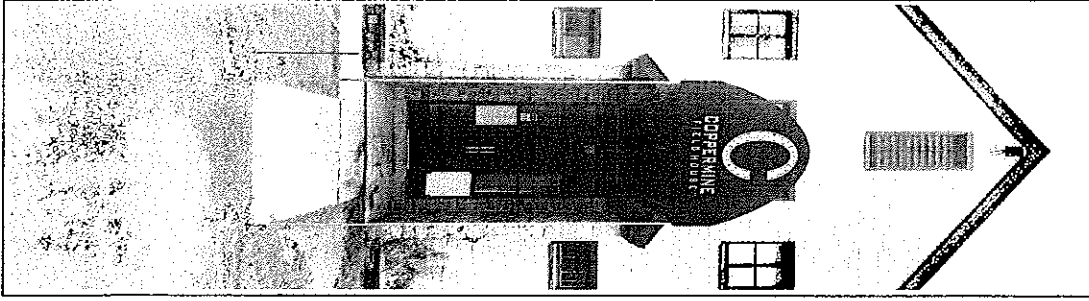

Attach Additional Photos

Approve

Disapprove

# NOTICE



**FACE MASK  
REQUIRED**

# NOTICE

*Application has been filed with the*

## Board of Liquor License Commissioners for Baltimore City

Address of Premises: 5602 Cotton worth Ave (AKA) 5731 Cotton worth Ave  
Class of License: BD7- Beer, Wine + Liquor  
Scope of Application: 1  
Transfer of ownership and location of a Class "BD7" Beer, Wine and Liquor license presently located at 5736 Falls Rd to 5731 Cotton worth Ave.  
Application filed by: Inkwork, Inc. T/A Coppermine  
Mark Larkin, Jr, ~~out~~  
Present Licensee(s): Curb Shoppe, LLC T/A Curb Shoppe  
James Little

The hearing concerning this application will be held after Sept 9, 2021  
Persons who oppose this application should send their written protest to the office of the Board at 1 N. Charles Street, Suite 1500, Baltimore, Maryland 21201. Written protests will be acknowledged and protestants will be notified of the hearing date and time.

**FOR MORE INFORMATION CALL  
410-396-4377**

Hon. Albert J. Marisciani, Jr., Esq.  
Aaron J. Greenfield, Esq.  
Robert L. Guy  
Douglas K. Page

Chairman  
Commissioner  
Commissioner  
Executive Secretary



# BLLC Routine Inspection

*Licensee information*

Address: 5736 FALLS ROAD 21209

Trade Name: CURB SHOPPE

Corporation Name CURB SHOPPE, LLC

Type of License: Class "BD7" Beer, Wine and Liquor

Date/Time of Inspection: 3/11/2020 10:38:20 AM

Manager/Licensee Kristen Wrightson

*Open/Closed Status*

Open/Closed: Open

Closed Date:

*External Appearance*

Clean and Free of Debris: Satisfactory

*Internal Appearance*

Location of Bar: Front

Shape of Bar:

Condition of Bar Area/Floors: Satisfactory

Hot Water: Yes

Disinfectant Solution: Yes

Three Compartment/Washer: Yes

*Package Goods/BD7 Checklist*

Bulletproof Partitioning: N/A

Separate Pkg. Goods Dept.: N/A

Separate Pkg. Goods Store: N/A

Bar/Tavern Open and Operating: Yes

Selling Household/Grocery: N/A

Dining Area

Capacity:

Location of Dining Area:

Condition of Dining Area/Floors: Satisfactory

Sanitation: Satisfactory

Menu: Yes

Business Records

Traders License: Yes

Alcohol Awareness Certification Date Issued: 4/10/2019

Employee Records: Yes

Alcohol Beverage Information Invoice Numbers and Date:

Kitchen

Inspector Comments:

Restroom

Inspector Comments:

Public Safety

Exits Marked, Unobstructed: Yes

Fire Capacity:

Outdoor Seating Capacity:

Adult Entertainment - If Applicable

License is Valid: N/A

Dancers Present 18 and older: N/A

Cleanliness of Dressing Room: N/A

*Amphibious Services*

Live Entertainment (Describe):

Outdoor Table Service N/A

*Violations*

Violation Issued: No

Violations Noted:

*Wrap-Up*

Instructions Given to Licensee:

Inspector's Comments:

Health permit expires 7/15/2020. Inspected on 3/10/2020 by Chase.

Photo Taken:

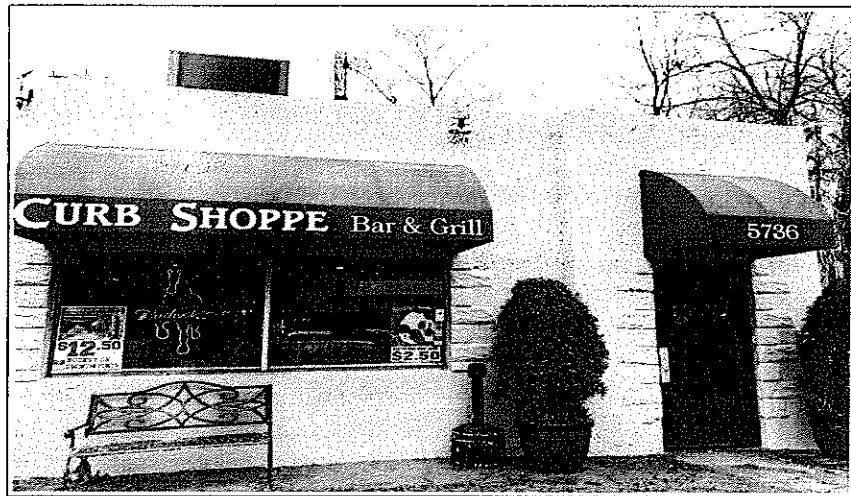

Owner Email:

Submitted by Inspector

Department Of: Housing And Community Development  
 Division Of Construction And Building Inspection

**Online Use & Occupancy Permit  
 Application**

Property Address: 5731 COTTONWORTH AVE  
 Block/Lot: 4778B/055A  
 Applicant: STEPHAN FOGLEMAN  
 Owner/Lessee:  
 Owner: NORTHWEST PARTNERS, LLC  
 Lessee: INKWORKS, INC.

Permit No: **USE2020-55443**

1001-000000-2600-159400-400540 Filing Fee	50.00
1001-000000-1500-102800-400230 Tax	3.00
1001-000000-2600-158009-400480 Use&Occupancy	45.00
<b>Total :</b>	<b>98.00</b>

**Please pay the Use & Occupancy permit fee  
 before scheduling inspections.**

**Property Use & Occupancy Information:**

Existing Use : (Commercial) Recreation: Indoor

Proposed Use : (Commercial) Recreation: Indoor

	Dwelling:	Roomming:	Efficiency:
Existing Count:	000	000	000
Proposed Count:	0	0	0

Description	Created	Completed	Assigned To
FIRE INSPECTION	12/03/2020		JGIB
HEALTH DEPARTMENT INSPECTION	11/30/2020		JWEL
Application Received		11/30/2020	
Zoning Sign-off	11/30/2020	11/30/2020	
One Stop Permit Office Review	11/30/2020		LONG
FIRE DEPARTMENT REFERRAL	11/30/2020	12/03/2020	LDZI
F01 - FLOODWAY	11/30/2020	12/02/2020	KKNO

District:502

MINOR PRIVILEGE:

THIS IS NOT A PERMIT. THIS DOCUMENT IS PROOF OF APPLICATION FOR A PERMIT. YOU MUST OBTAIN THE ACTUAL PERMIT OR CERTIFICATE OF OCCUPANCY BEFORE THE BELOW STATED WORK OR USE CAN BEGIN. FOR MORE INFORMATION CONTACT THE ONE STOP SHOP PERMIT CENTER AT 443-984-1809.

CONTINUE TO USE AS A RECREATIONAL FACILITY ADDING ACCESSORY RESTAURANT/SNACK BAR

**AFFIDAVIT BY: STEPHAN W FOGLEMAN**

THE OWNER OF THE DESCRIBED PROPERTY FOR THE PROJECT NAMED BELOW HEREBY APPROVED THIS PERMIT APPLICATION AND AGREES TO COMPLY WITH ALL ORDINANCES OF THE MAYOR AND CITY COUNCIL OF BALTIMORE AND TO DO NO WORK NOT SPECIFICALLY COVERED BY THIS APPLICATION. "I DECLARE UNDER PENALTIES OF PERJURY THAT THIS APPLICATION, INCLUDING ANY ACCOMPANYING PLANS, SPECIFICATIONS, ETC. HAS BEEN EXAMINED BY ME AND TO THE BEST OF MY KNOWLEDGE AND BELIEF IS A TRUE, CORRECT AND COMPLETE STATEMENT OF THE WORK TO BE COVERED BY THIS APPLICATION. I ALSO DECLARE THAT I AM THE OWNER OR HAVE SPECIFIC APPROVAL OF THE OWNER TO ACT AS AGENT FOR THIS APPLICATION .

Project Name: COPPERMINE

Owner First Name:

Role: Agent

Owner Last Name Or Company Name: NORTHWEST PARTNERS, LLC

Applicant: FOGLEMAN,STEPHAN

Phone:

Project Note:

Address1:

Address2:

City:

State:

Zip:

**September 30, 2021**

**Applicant(s):** Jasimin Jones  
Chedda John's, LLC, T/a Chedda John's  
1184-86 Nanticoke Street 21230

**Class:** "BD7" Beer, Wine & Liquor License

Application to transfer ownership.

(a) **Applicant(s) Information:** (1) Jasimin Jones was born in Baltimore, MD in July of 1990. She lives in Baltimore, MD.

(b) **Ownership Breakdown:** (1) Jasimin Jones (100%).

(c) **Purchase Price of Business:** Commercial lease to be paid at \$4,250 per month for 5 years.

(d) **Qualified Voters:** Kennishia L. Boone, Shanay Gregory and Paulette Stiff are qualified Baltimore City voters.

(e) **Zoning:** Applicant has applied for a USE permit, for the use of property 1<sup>st</sup> floor as a restaurant and basement for storage.

(f) **Corporate Standing:** Chedda John's, LLC is a MD LLC and as of 9/10/2021 is active and in good standing.

(g) **Posting Report:** The location was posted on 8/17/2021, and will be checked on 8/26/2021. This meets the 10-day rule. There are 3 licensed liquor establishment(s) in the 2x2 area "A" BW-1; and "BD7" BWL-2.

(h) **Timeline:** Last Inspection by BLLC was performed on 8/19/2021. At that time, the establishment was closed. Licensed Establishment closed in March of 2020. On 3/12/2020, the Governor issued an Executive Order that extended timelines under Alc. Bev. Article 12-2202. License is Valid.

(i) **Letters of Support/Opposition:** At this time the Board has no letter(s) of opposition or support.

In considering this request, under the provisions of Alcohol Beverages Article 4-210(A) the Board must consider the following factors: 1. The public need and desire for the license; 2. The number and location of existing license holders; 3. The potential effect on existing license holders of the license for which application is made; 4. The potential commonality or uniqueness of the services and products to be offered by the business of the applicant; 5. The impact of the license for which application is made on the health, safety, and welfare of the community, including issues relating to crime, traffic conditions, parking, or convenience; and 6. Any other factor that the local licensing Board considers necessary.

**Board's Decision:**

2020 Application for Alcoholic Beverages License Board of Liquor License Commissioners for Baltimore City

NEW/TRANSFER/EXPANSION/AMENDMENT(S) APPLICATION FEE - \$600.00

INDICATE TYPE OF LICENSE APPLICATION: TRANSFER  NEW  EXPANSION OF PREMISES  AMENDMENT(S)

EXPLANATION OF REQUEST: Transfer of Ownership Only CLASS TYPE: BD7

*Please select one option and fill out the requested information*

A) NEW LICENSE REQUEST: ADDRESS OF PROPOSED LOCATION: N/A

B) TRANSFER OF OWNERSHIP ONLY: ADDRESS OF CURRENT LICENSE: 1184-86 Nanticoke Street

C) TRANSFER OF OWNERSHIP AND LOCATION: CURRENT ADDRESS OF LICENSED LOCATION: N/A

TRANSFER OF OWNERSHIP AND LOCATION: ADDRESS OF PROPOSED RELOCATION: N/A

D) AMENDMENT OR EXPANSION REQUEST: ADDRESS OF THE LOCATION: N/A

CORPORATE/LLC/LLP/PARTNERSHIP NAME: Chedda John's LLC TRADE NAME: Chedda John's

BUSINESS PHONE NUMBER: 443-622-9864 BUSINESS EMAIL ADDRESS: jazzyjones0790@icloud.com

ATTORNEY FOR THE APPLICANT: Stephan W Fogleman Esq ADDRESS: 1720 Thames St #300 21231 PHONE: 410-258-8500

Part of Premises Used (Note: Floors and Areas for Storage): 1st fl business basement storage Outdoor Table Service Provided?  Yes  No Delivery of alcohol?  Yes  No

Live Entertainment provided?  Yes  No What Kind (Ex. DJ, Band, Etc.): \_\_\_\_\_ Off Premise Catering of Food and Alcohol?  Yes  No

Zoning Receipt or Current Certificate of Occupancy Permit attached to Application?  Yes  No Estimated Seating Capacity: 75

*Please note that as per Alc. Bev. Art. § 12-1407(A)(2), an application for the issuance or transfer, is not complete unless the applicant has obtained approval and/or verification from the Baltimore Municipal Zoning Appeals (BMZA)*

1. Applicant A

Jasimin Jones \_\_\_\_\_  
 (Full name) (Telephone no.) E-mail (Required)  
 5508 Lothian Road Baltimore MD 21212 30 years  
 (Residence) Street City State Zip Code (period of residency in Baltimore City)  
 07/90 F Baltimore City MD  
 (Month/Year of Birth) (Sex: Male or Female) (Place of Birth)  
 Check:  Yes  No Are you currently a resident of the City of Baltimore?

2. Applicant B

\_\_\_\_\_  
 (Full name) (Telephone no.) E-mail (Required)  
 \_\_\_\_\_  
 (Residence) Street City State Zip Code (period of residency in Baltimore City)  
 \_\_\_\_\_  
 (Month/Year of Birth) (Sex: Male or Female) (Place of Birth)  
 Check:  Yes  No Are you currently a resident of the City of Baltimore?

3. Applicant C

\_\_\_\_\_  
 (Full name) (Telephone no.) E-mail (Required)  
 \_\_\_\_\_  
 (Residence) Street City State Zip Code (period of residency in Baltimore City)  
 \_\_\_\_\_  
 (Month/Year of Birth) (Sex: Male or Female) (Place of Birth)  
 Check:  Yes  No Are you currently a resident of the City of Baltimore?

**RECEIVED**

JUL 01 2021

Baltimore City  
Liquor Board

1. Has the applicant(s) been adjudged guilty of a felony in the State of Maryland or any other?  Yes  No - If yes, indicate applicant and explain.  
Applicant A  B  C

[Redacted area]

2. Has the applicant(s) been adjudged guilty of violating the laws governing the sale of any alcoholic beverage or for gambling in any State, including Maryland?  Yes  No - If yes, mark applicant and provide explanation in adjacent space provided.  
Applicant A  B  C

[Redacted area]

3. State whether the applicant(s) has ever been adjudged guilty of any offense against the laws of the State of Maryland, any other State within the United States, or against the United States (Federal Crime)?  Yes  No - If yes, mark applicant and explain.  
Applicant A  B  C

A: Although not convicted, Applicant was arrested in 2015 for CD5  
Att Poss Dist, Baltimore City Circuit Court

4. Has the applicant(s) ever had a license for the sale of alcoholic beverages in the State of Maryland?  Yes  No If yes, mark applicant and explain (address of location, dates that the applicant was a licensee, and the trade name).  
Applicant A  B  C

[Redacted area]

5. Has the applicant(s) ever had a liquor license suspended or revoked?  Yes  No If yes, mark applicant and explain.  
Applicant A  B  C

[Redacted area]

6. Does the applicant(s) have a financial interest in any other alcoholic beverage business or business for which an alcoholic beverage license has been applied for, granted, and issued?  Yes  No If yes, mark applicant and explain (address of location and trade name).  
Applicant A  B  C

[Redacted area]

7. Do the spouses or dependent children of any of the applicant(s) have a financial interest in any other alcoholic beverages license or business in Baltimore City or any other jurisdiction in the State of Maryland?  Yes  No If yes, mark applicant and explain (address of location and trade name).  
Applicant A  B  C

[Redacted area]

8. Are you financially interested in any other alcoholic beverages license applied, granted or issued?  Yes  No If yes, please explain.  
Applicant A  B  C

[Redacted area]

9. Is the licensed premise currently open and operating?  Yes  No If no, then provide date of last day of operation of the establishment.

8/2020

10. Do any of the applicant(s) - personally or through an entity - have any indebtedness or other financial obligations to any manufacturer, brewer, distiller, or wholesaler at the time of making this application?  Yes  No If yes, please explain. If yes, please provide information as to the applicant(s) indebted - personally or through an entity - the amount of the indebtedness, and the name of the manufacturer, brewer, distiller, or wholesaler?  
Applicant A  B  C

[Redacted area]



II. Please list the following information for the Manager of the establishment to be licensed:

Name	Address	Phone	Email
Darius Divers	4090 Hilltop Rd Baltimore 21212	[REDACTED]	[REDACTED]

Applicants Applying as Business Entities - (Give name(s) and addresses - in Corporation list all officers (attach list if necessary) or in Limited Liability Company/Partnerships list all authorized persons.) *Please note that all licensees MUST have a FINANCIAL INTEREST in the license applied for as per Alc. Bev. Art. § 4-109 (a)(10). If necessary, please attach a list of the names and address of all outstanding stock holders who at the time of application own any stock of the corporation and the articles of incorporation, partnership agreement or articles of organization.*

- 1) NAME: Jasmin Jones ADDRESS: 5508 Lothian Road TITLE: Owner %OF STOCK HELD: 100
- 2) NAME: \_\_\_\_\_ ADDRESS: \_\_\_\_\_ TITLE: \_\_\_\_\_ %OF STOCK HELD: \_\_\_\_\_
- 3) NAME: \_\_\_\_\_ ADDRESS: \_\_\_\_\_ TITLE: \_\_\_\_\_ %OF STOCK HELD: \_\_\_\_\_
- 4) NAME: \_\_\_\_\_ ADDRESS: \_\_\_\_\_ TITLE: \_\_\_\_\_ %OF STOCK HELD: \_\_\_\_\_

*\*Extract from Law: If any affidavit or oath required under the provisions of this Act shall contain any false statements, the offender shall be deemed guilty of perjury. And upon indictment and conviction thereof, shall be subject to penalties provided by Law for that crime.*

**CERTIFICATE OF APPLICANTS:** At least one applicant whose signature appears below certifies that he/she is a current resident of Baltimore City, Maryland at the time of filing of this application. Each of said applicants hereby certifies further that if the license applied for is granted, he/she will conform to all State and County laws and regulations relating to the sale of alcoholic beverages, as well as to the rules and regulations of the Board of License Commissioners for Baltimore City, and hereby grants permission to the State Comptroller, his duly authorized deputies, inspectors and clerks, The Board of License Commissioners for Baltimore City, its duly authorized agents and employees, and any peace officer of Baltimore City or the State of Maryland to inspect and search at any and all hours, without warrant, the premises and any and all parts thereof upon and in which said business is to be conducted. If license is issued, the applicants must ensure that at least one licensee remains a resident of Baltimore City throughout the duration of this license.

[Signature]  
Signature of Applicant A

I hereby certify that on the 21 day of June, 2021, before me, the subscriber, a notary public of the State of Maryland in and for Baltimore City, personally appeared Jasmin Jones the applicant(s) named in this application made oath in due form of law that the matter and facts contained in said application are true and correct. As witness, my hand and notarial seal.

Signature: [Signature] [Notary Seal] My Commission expires 12/16/22  
Printed Name: Stephan W Fogelman, Jr.

Signature of Applicant B

I hereby certify that on the \_\_\_\_\_ day of \_\_\_\_\_, 20\_\_\_\_, before me, the subscriber, a notary public of the State of \_\_\_\_\_ in and for \_\_\_\_\_, personally appeared \_\_\_\_\_ the applicant(s) named in this application made oath in due form of law that the matter and facts contained in said application are true and correct. As witness, my hand and notarial seal.

Signature: \_\_\_\_\_ [Notary Seal] My Commission expires \_\_\_\_\_  
Printed Name: \_\_\_\_\_

Signature of Applicant C

I hereby certify that on the \_\_\_\_\_ day of \_\_\_\_\_, 20\_\_\_\_, before me, the subscriber, a notary public of the State of \_\_\_\_\_ in and for \_\_\_\_\_, personally appeared \_\_\_\_\_ the applicant(s) named in this application made oath in due form of law that the matter and facts contained in said application are true and correct. As witness, my hand and notarial seal.

Signature: \_\_\_\_\_ [Notary Seal] My Commission expires \_\_\_\_\_  
Printed Name: \_\_\_\_\_

Name and Address of the owners of the premise/landlord: ELST LLC Phone Number: 

**STATEMENT OF OWNER OF PREMISES REQUIRED IN CONNECTION WITH ALCOHOLIC BEVERAGES LAW OF MARYLAND**

(I, WE) Ryle Leibowitz HEREBY CERTIFY, That (I am, we are) the owner(s) of the property located at 1187 Nantuxet St, Baltimore, City with a Zip Code of 21230, which is named in the present application made to the Board of Liquor License Commissioners of Baltimore City under the Alcoholic Beverage Laws of Maryland and assent to the granting of the license applied for, and hereby authorize the State Comptroller, his duly authorized deputies, inspectors and clerks, the Board of Liquor License Commissioners of Baltimore City, its duly authorized agents and employees, and any peace officer of the City of Baltimore and State of Maryland, to inspect and search, without warrant, the premises upon which the business is to be conducted, and any and all parts of the building in which said business is to be conducted, at any and all hours.

  
Signature of Owner of the Property

I hereby certify that on the 25 day of June, 2021, before me, the subscriber, a notary public of the State of Maryland, in and for Baltimore City personally appeared \_\_\_\_\_ the landlord/property owner named in this application made oath in due form of law that the matter and facts contained in said application are true and correct.

As witness, my hand and notarial seal.

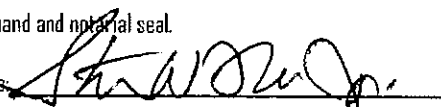
Notary Signature:  (Notary Seal) My Commission expires 12/16/22  
Notary Printed Name: Stephen W Fogelmann Jr.

**STEPHAN W. FOGELMANN, JR.**  
**NOTARY PUBLIC STATE OF MARYLAND**  
My Commission Expires 12/16/22

The following certificates must be signed by at least 3 persons.

We, the undersigned citizens, real estate owners and registered voters in the City of Baltimore in which the business covered by the present application is to be conducted. We certify that the qualifying applicant(s) is/are personally known to us and is a resident of Baltimore City and a resident of the State of Maryland at the time of this application.

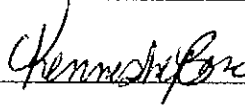
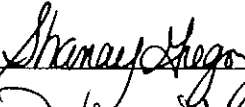
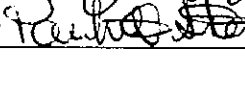
Names	Address	Signature	DOB (Month/Year)	Length of time Acquainted with the Applicant(s)
<u>Kennisha Beune</u>	<u>5116 Ardmore Way</u>		<u>04/14/71</u>	<u>29 yrs</u>
<u>Shanay Gregory</u> <u>Mayo</u>	<u>2716 Cyburn Ave</u>		<u>05/19/85</u>	<u>28 yrs</u>
<u>Paulette Still</u>	<u>3745 Rowenwood Ave</u>		<u>08/1977</u>	<u>43 years</u>

Board of Liquor License Commissioners for the City of Baltimore  
1 North Charles Street, Suite 1500, Baltimore, Maryland 21201  
Phone: 410-396-4377 Fax: 410-396-4382

Please note that this is a public document and upon request will be provided to the general members of the public.

Nanticoke Street

Door

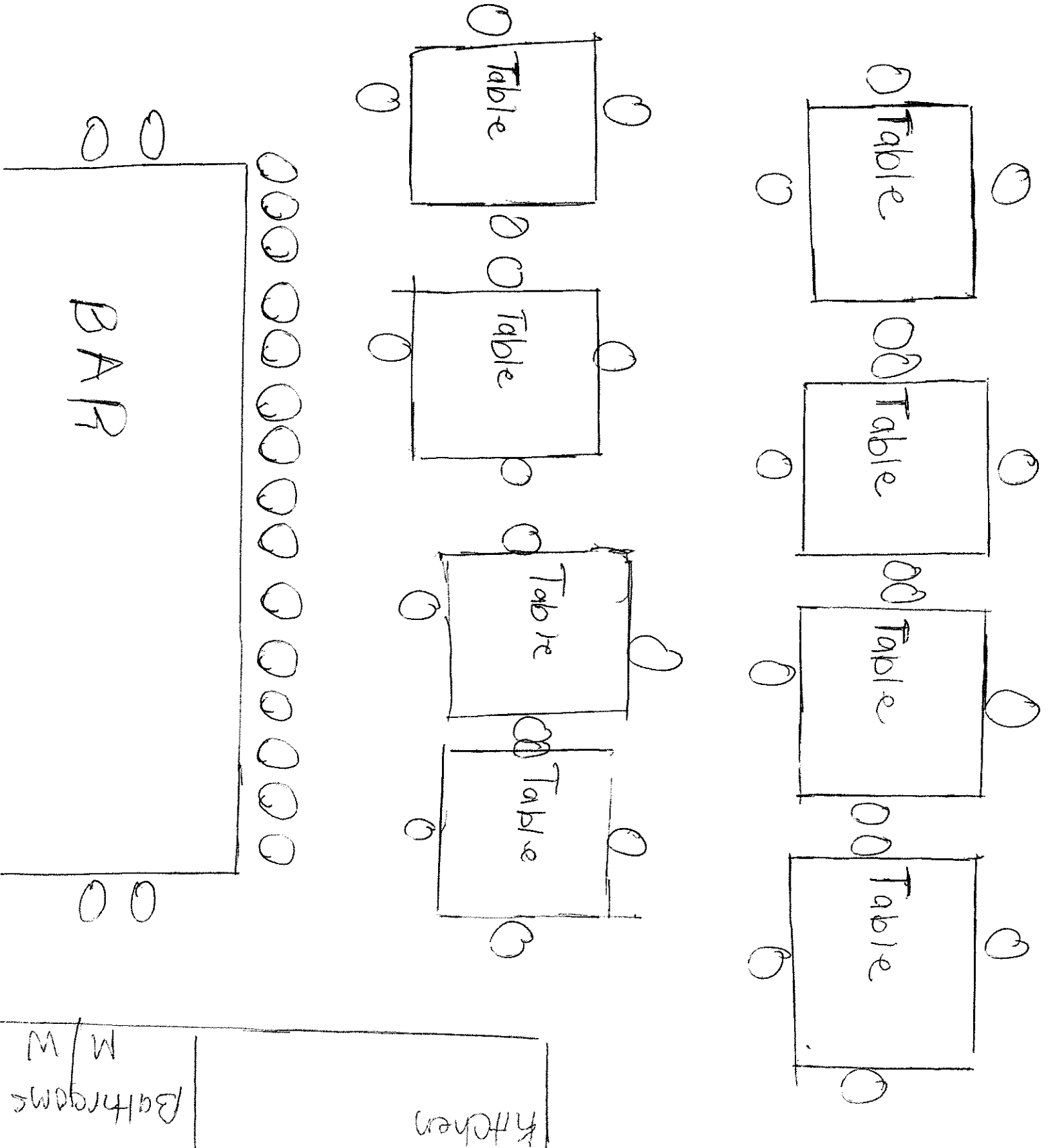



## Liquor Board System

Version 1.0

Annual-Renewal ▼ | License-Transfer ▼ | One-Day ▼ | Add New License ▼ | Query ▼ | Help ▼

### License Detail

#### License Info

License Num: **LBD7 357**      Cert Num: **0975**      Fee: **\$1,320.00**      Status: **Renewed**  
 License Date: 5/1/2021      License Year: 2021  
 CR Number: 06462927  
 Payment Date: 08-25-21

2020 - 2021 TPP Paid   
 2021 Trader's License

[Click to Start License Renewal](#)

### Add Adult Entertainment License

#### Location

Corp Name: **FIELDER'S, INC.**  
 Trade Name: **FIELDER'S TAVERN**  
 Zone Code: 5  
 Phone: 410-727-1890

Block Num: 1184-86      Street: NANTICOKE STREET  
 City: BALTIMORE      State: MD      Zip: 21230

CR Number: 06462927

Portion of Business Used:  
 FIRST FLOOR AND GARAGE FOR BUSINESS AND BASEMENT FOR STORAGE

Restriction:  
 NO ALCOHOLIC BEVERAGES MAY BE SOLD OR CONSUMED IN THE GARAGE AREA

#### License Owners

First Name	Last Name	Street	City	State	Zip	Action	Change Owner
MICHAEL D	DAY	421 WELLHAM AVENUE	GLEN BURNIE	MD	21061	<input type="button" value="Edit"/>	<input type="button" value="Remove Owner"/>
VALERIE A.	DAY	421 WELLHAM AVENUE	GLEN BURNIE	MD	21061	<input type="button" value="Edit"/>	<input type="button" value="Remove Owner"/>

#### Comments

--

Date	Comment	Action
07/12/2021	Application for transfer of ownership filed on behalf of Chedda John's, LLC T/a Chedda John's, Jasimin Jones on 7/1/2021 /kk	Delete
03/12/2019	Alcohol Awareness expires on March 08, 2023; certified by John S Murray (Michael Day).... /sb	Delete
08/25/2015	Submitted 2014-2015 statement on Personal Property Tax.... /sb	Delete
05/06/2015	Alcohol Awarness exprise on 4/11/2019 (Michael D. Day)	Delete
03/01/2004	6/20/96 Public hearing re: Violation of Rule 4.18 (illegal act), i Rule 3.12 (Disturbing the community), Rule 4.05(a) & (b) (after i hours) Decision: Ruels 4.05(b), 4.18 and 3.12 dismissed Rule i 4.01(a) guilty 5 days or \$500 reduced to 1 day or \$100 6/26/96 i \$100 fine paid BT 00949	Delete

[Print History \(Print Card\)](#)

License num: LBD7 357                      Address: 1184-86 NANTICOKE STREET  
 Trade Name: FIELDER'S TAVERN

Comment:

[Add Comment](#)

**Hold Info**

Powered by:



## CHEDDA JOHN'S LLC: W21577051

**Department ID Number:**

W21577051

**Business Name:**

CHEDDA JOHN'S LLC

**Principal Office:** 

1184 NANTICOKE ST  
BALTIMORE MD 21230

**Resident Agent:** 

DARIUS DIVERS  
27 SHAWNEE COURT  
APT 102  
PARKVILLE MD 21234

**Status:**

ACTIVE

**Good Standing:**

THIS BUSINESS IS IN GOOD STANDING

**Business Type:**

DOMESTIC LLC

**Business Code:**

20 ENTITIES OTHER THAN CORPORATIONS

**Date of Formation/ Registration:**

03/22/2021

**State of Formation:**

MD

**Stock Status:**

N/A

**Close Status:**

N/A

PROPOSED LOCATION: 1184-86 Nanticoke St.

### MAP SUMMARY (RECAPITULATION)

TOTAL ESTABLISHMENTS IN MAP AREA 3

"A" BEER & WINE 1

"B" BEER & WINE \_\_\_\_\_

"C" BEER & WINE \_\_\_\_\_

"D" BEER & WINE \_\_\_\_\_

"A" BEER, WINE & LIQUOR \_\_\_\_\_

"A-2" BEER, WINE & LIQUOR \_\_\_\_\_

"B" BEER, WINE & LIQUOR \_\_\_\_\_

"C" BEER, WINE & LIQUOR \_\_\_\_\_

"D" BEER, WINE & LIQUOR \_\_\_\_\_

"BD7" BEER, WINE & LIQUOR 2

ARENA \_\_\_\_\_

HOTEL/MOTEL \_\_\_\_\_

RACING \_\_\_\_\_

PREPARED BY: Steven Han DATE: 8/19/21





# Board of Liquor License Commissioners

For Baltimore City  
1 North Charles Street, 15th Floor  
Baltimore, Maryland, 21201

## INSPECTORS REPORT - TRANSFERS/NEW APPLICATIONS

Licensee Information (Trade Name):	<input type="text" value="CHEDDA JOHN'S"/>
Corporation Name:	<input type="text" value="CHEDDA JOHN'S LLC"/>
Location Address:	<input type="text" value="1184-86 NANTICOKE ST"/>
License Type:	Class "BD7" Beer, Wine and Liquor <input type="button" value="v"/>
Is the establishment open and operating in a safe and sanitary manner? (If not open, not in comments - CLOSED or NOT OPERATING)	No <input type="button" value="v"/>
Is the location within 300 feet of Church and/or School?	Yes <input type="button" value="v"/>
Date Posted?	<input type="text" value="8/17/2021"/> <input type="button" value="calendar"/>
Estimated Date of Removal?	<input type="text" value="8/26/2021"/> <input type="button" value="calendar"/>
Are there any other licensed establishments within a two block radius?	Yes <input type="button" value="v"/>

Other licensed locations - Describe/Note:

see map

Comments and Follow-up Items(s) (please note any issues or concerns about the location):

Transfer new ownership

Insert Photo of Sign and location:

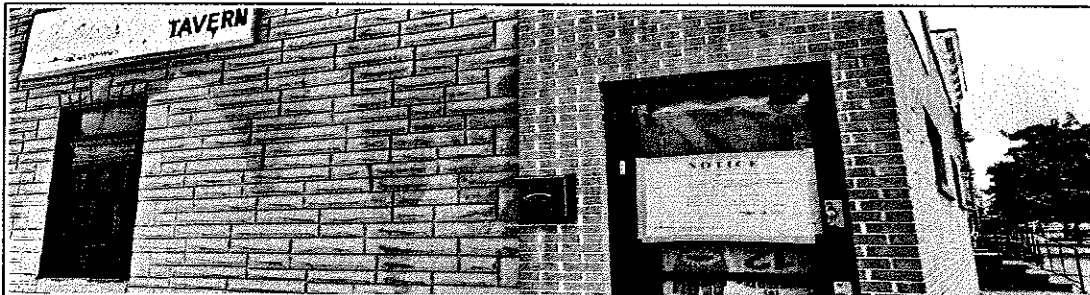

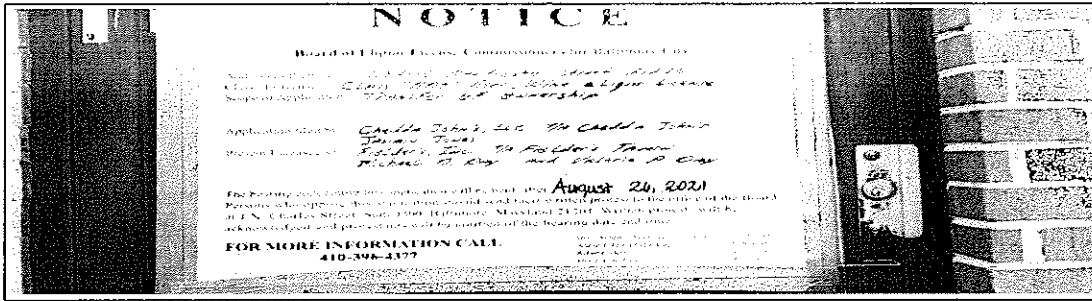

Attach Additional Photos

Inspector Name	Date and Time	
i:\0#w\baltimore\steven.han	8/25/2021	10:48:36 AM
Name of Licensee (if present)		
<input type="text"/>		
Approve		Disapprove

Board of Liquor License Commissioners

For Baltimore City  
1 North Charles Street, 15th Floor  
Baltimore, Maryland, 21201

**POSTING SIGNS REPORT**

Applicant(s) Name: JAMES RANDALL BISS JR.

Address of Premises: 1184 NANTICOK ST.

Inspector: i:0#w|baltimore\steven.han

Date Posted: 8/17/2021

Time Posted:

Date Rechecked: 8/26/2021

Time Rechecked:

Manager or Owner when sign posted:

Summary on location of sign posted:

FRONT DOOR

Summary on location of sign rechecked:

Was up for ten days

Insert Photo of Sign and location:

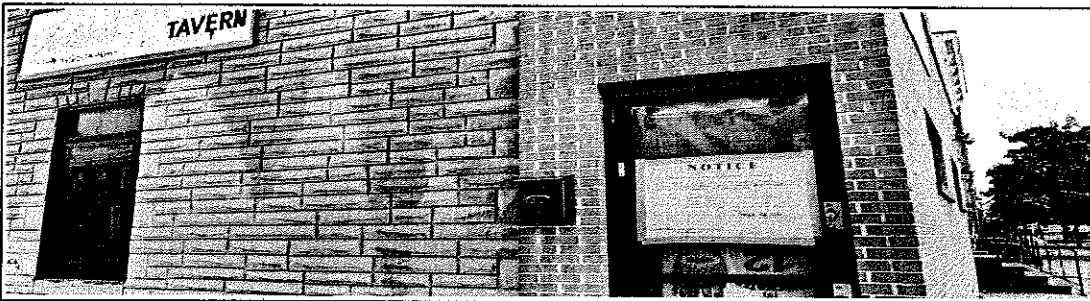

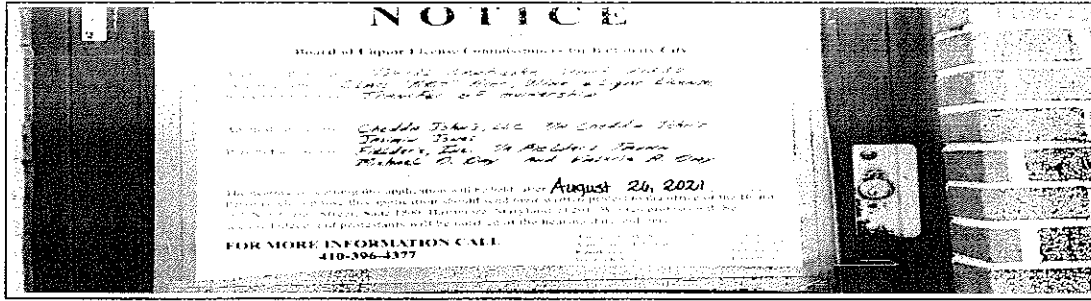

Attach Additional Photos

Approve

Disapprove

# NOTICE

Application has been filed with the

## Board of Liquor License Commissioners for Baltimore City

Address of Premises: 1184-86 Nanticoke Street 21230  
Class of License: Class "BD7" Beer, Wine & Liquor License  
Type of Application: Transfer of Ownership  
Application filed by: Chedda Johns, LLC TA Chedda Johns  
Jasmin Jones  
Present Licensee(s): Fielder's, Inc. TA Fielder's Tavern  
Michael D. Day And Valerie A. Day

A hearing concerning this application will be held after August 24, 2021  
Persons who oppose this application should send their written protest to the office of the Board  
1 N. Charles Street, Suite 1500, Baltimore, Maryland 21201. Written protests will be  
acknowledged and protestants will be notified of the hearing date and time.

**FOR MORE INFORMATION CALL**  
**410-396-4377**

Hon. Albert J. Matricciani, Jr., Esq.      *Chairman*  
Aaron J. Greenfield, Esq.                *Commissioner*  
Robert E. Guye                                *Commissioner*  
Douglas K. Paige                             *Executive Secretary*

Back

# BLLC Compliance Inspection

Address: 1184-86 NANTICOKE STREET 21230 ▼

Trade Name: FIELDER'S TAVERN

Corporation Name: FIELDER'S, INC.

Type of License: Class "BD7" Beer, Wine and Liquor ▼

Date/Time of Inspection: 8/19/2021 12:43:02 PM

Manager/Licensee

## Inspection Status

Open/Closed: Closed ▼

Closed Date: 8/17/2021

## Inspection Details

Clean and Free of Debris: N/A ▼

## Inspection Notes

Traders License: N/A ▼

Alcohol Awareness Certification Date Issued:

## Inspection Safety

Exits Marked, Unobstructed: N/A ▼

Fire Capacity:

Outdoor Seating Capacity:

## Adult Entertainment - If Applicable

License is Valid: N/A ▼

## Violations

Violation Issued: No ▼

Violations Noted:

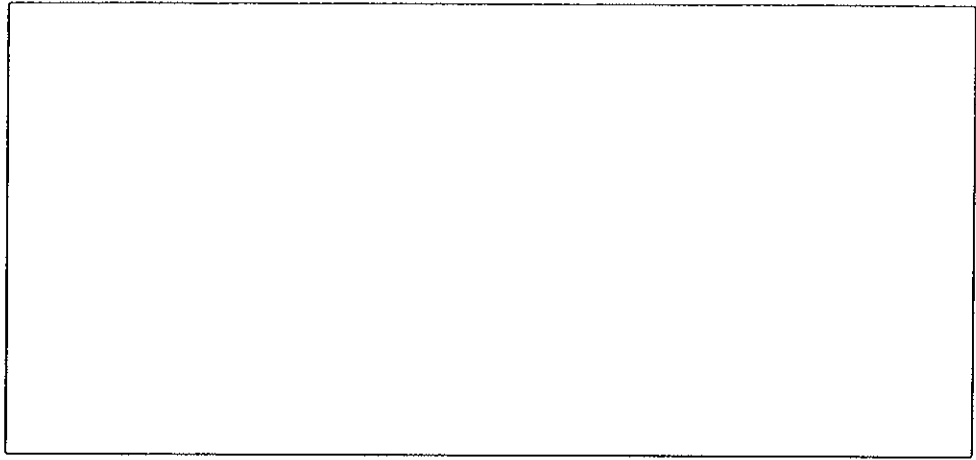

Instructions Given to Licensee:

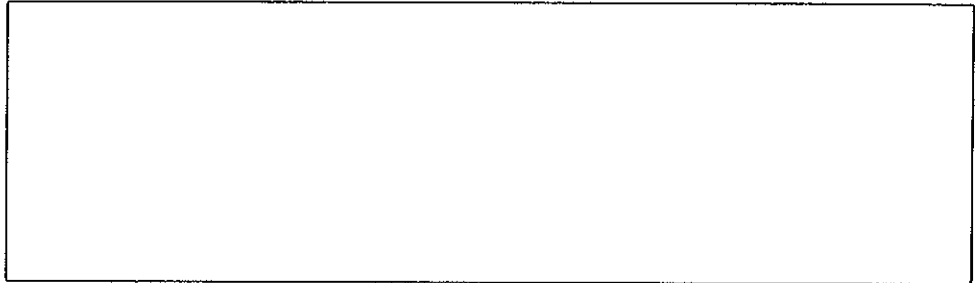

Inspector's Comments:

CLOSED AT THE TIME OF INSPECTION 8/17/2021

Photo Taken:

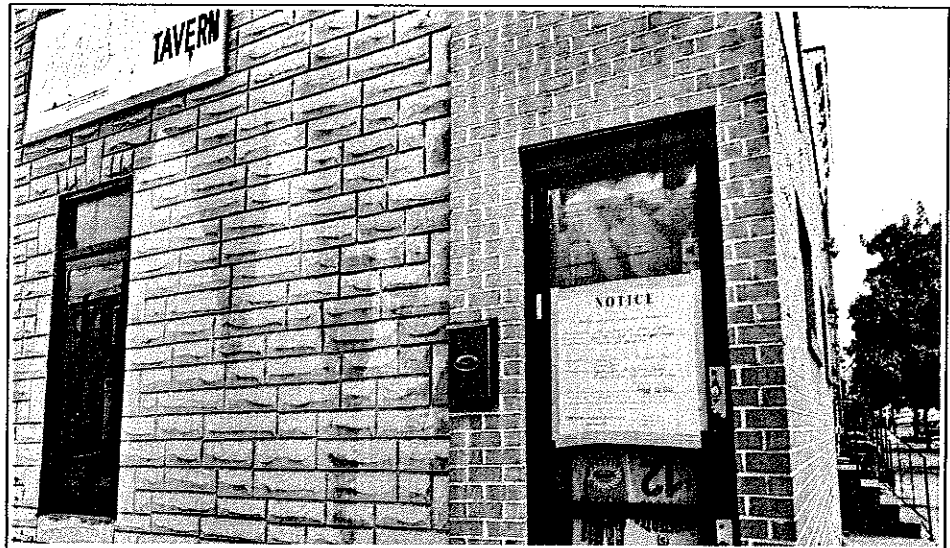

Attach Additional Photos

Owner Email:

Submitted by Inspector

Department Of Housing And Community Development  
 Division Of Construction And Building Inspection

**Online Use & Occupancy Permit  
 Application**

Property Address: 1184 NANTICOKE ST Block/Lot: 0791/033

Permit No: **USE2021-52899**

Applicant:  
 STEPHAN FOGLEMAN

1001-000000-2600-159400-400540 Filing Fee	50.00
1001-000000-1500-102800-400230 Tax	3.00
1001-000000-2600-158009-400480 Use&Occupancy	45.00
<b>Total :</b>	<b>98.00</b>

Owner/Lessee:  
 Owner EIST LLC

Lessee CHEDDA JOHN'S LLC

**Please pay the Use & Occupancy permit fee  
 before scheduling inspections.**

**Property Use & Occupancy Information:**

Existing Use : (Commercial) Tavern

Proposed Use : (Commercial) Restaurant

	Dwelling:	Rooming:	Efficiency:
Existing Count:	001	000	000
Proposed Count:	0	0	0

Description	Created	Completed	Assigned To
FIRE DEPARTMENT REFERRAL	06/22/2021		LDZI
HEALTH DEPARTMENT INSPECTION	06/22/2021		JWEL
Application Received		06/21/2021	
Zoning Sign-off	06/21/2021	06/21/2021	
One Stop Permit Office Review	06/22/2021		SMIT
R35- WASHINGTON VILLAGE	06/22/2021		JLAN

District:902

**MINOR PRIVILEGE:**

THIS IS NOT A PERMIT. THIS DOCUMENT IS PROOF OF APPLICATION FOR A PERMIT. YOU MUST OBTAIN THE ACTUAL PERMIT OR CERTIFICATE OF OCCUPANCY BEFORE THE BELOW STATED WORK OR USE CAN BEGIN. FOR MORE INFORMATION CONTACT THE ONE STOP SHOP PERMIT CENTER AT 443-984-1809.

USE FIRST FLOOR FOR RESTAURANT AND BASEMENT FOR STORAGE PER BMZA2020-151.

**AFFIDAVIT BY: STEPHAN W FOGLEMAN**

THE OWNER OF THE DESCRIBED PROPERTY FOR THE PROJECT NAMED BELOW HEREBY APPROVED THIS PERMIT APPLICATION AND AGREES TO COMPLY WITH ALL ORDINANCES OF THE MAYOR AND CITY COUNCIL OF BALTIMORE AND TO DO NO WORK NOT SPECIFICALLY COVERED BY THIS APPLICATION. "I DECLARE UNDER PENALTIES OF PERJURY THAT THIS APPLICATION, INCLUDING ANY ACCOMPANYING PLANS, SPECIFICATIONS, ETC. HAS BEEN EXAMINED BY ME AND TO THE BEST OF MY KNOWLEDGE AND BELIEF IS A TRUE, CORRECT AND COMPLETE STATEMENT OF THE WORK TO BE COVERED BY THIS APPLICATION. I ALSO DECLARE THAT I AM THE OWNER OR HAVE SPECIFIC APPROVAL OF THE OWNER TO ACT AS AGENT FOR THIS APPLICATION .

Project Name: 1184 NANTICOKE  
 Role: Agent  
 Applicant: FOGLEMAN,STEPHAN

Owner First Name:  
 Owner Last Name Or Company Name: EIST LLC  
 Phone:

Project Note:

Address1:  
 Address2:  
 City:  
 State:  
 Zip:



**September 30, 2021**

**Applicant(s):** Edwin Aguilar and Dany Lopez  
O’Ryan, LLC, T/a O’Ryan’s Pub  
53-55 S. Kresson Street 21224

**Class:** “BD7” Beer, Wine & Liquor License

Application to transfer ownership.

(a) **Applicant(s) Information:** (1) Edwin Aguilar was born in Guatemala in May of 1987. He lives in Baltimore, MD; and (2) Dany Lopez was born in EL Salvador in September of 1985. He lives in Baltimore, MD.

(b) **Ownership Breakdown:** (1) Edwin Aguilar (50%); and (2) Dany Lopez (50%).

(c) **Purchase Price of Business:** The purchase price of the business is \$130,000 to be paid at closing.

(d) **Qualified Voters:** Jose Ribadeneira, Johanna Sternberg, and Alice L. Kistner are qualified Baltimore City voters.

(e) **Zoning:** Applicant has applied for a USE permit, for the use of the property 1<sup>st</sup> floor as a tavern/carry-out and 2<sup>nd</sup> floor as a dwelling.

(f) **Corporate Standing:** O’Ryan, LLC is a MD LLC and as of 9/15/2021 is active and in good standing.

(g) **Posting Report:** The location was posted on 9/1/2021, and will be checked on 9/13/2021. This meets the 10-day rule. There are 8 licensed liquor establishment(s) in the 2x2 area “B” BWL-2; “D” BWL-2; and “BD7” BWL-4.

(h) **Timeline:** Last Inspection by BLLC was performed 7/31/2021. At that time, the establishment was open and operating.

(i) **Letters of Support/Opposition:** At this time the Board has no letter(s) of opposition or support.

In considering this request, under the provisions of Alcohol Beverages Article 4-210(A) the Board must consider the following factors: 1. The public need and desire for the license; 2. The number and location of existing license holders; 3. The potential effect on existing license holders of the license for which application is made; 4. The potential commonality or uniqueness of the services and products to be offered by the business of the applicant; 5. The impact of the license for which application is made on the health, safety, and welfare of the community, including issues relating to crime, traffic conditions, parking, or convenience; and 6. Any other factor that the local licensing Board considers necessary.

**Board’s Decision:**

2020 Application for Alcoholic Beverages License Board of Liquor License Commissioners for Baltimore City

NEW/TRANSFER/EXPANSION/AMENDMENT(S) APPLICATION FEE - \$600.00

INDICATE TYPE OF LICENSE APPLICATION: TRANSFER  NEW  EXPANSION OF PREMISES  AMENDMENT(S)

EXPLANATION OF REQUEST: transfer of ownership only CLASS TYPE: BD7

*Please select one option and fill out the requested information*

A) NEW LICENSE REQUEST: ADDRESS OF PROPOSED LOCATION: N/A

B) TRANSFER OF OWNERSHIP ONLY: ADDRESS OF CURRENT LICENSE: 53-55 S Kresson Street 21224

C) TRANSFER OF OWNERSHIP AND LOCATION: CURRENT ADDRESS OF LICENSED LOCATION: N/A

TRANSFER OF OWNERSHIP AND LOCATION: ADDRESS OF PROPOSED RELOCATION: N/A

D) AMENDMENT OR EXPANSION REQUEST: ADDRESS OF THE LOCATION: N/A

CORPORATE/LLC/LLP/PARTNERSHIP NAME: O'Ryan, LLC TRADE NAME: O'Ryans Pub

BUSINESS PHONE NUMBER: 410-878-0133 BUSINESS EMAIL ADDRESS: edaguilar0605@gmail.com

ATTORNEY FOR THE APPLICANT: Stephan W. Fogleman Esq ADDRESS: 1720 Thames Street #300 21231 PHONE: 410-258-8500

Part of Premises Used (Note: Floors and Areas for Storage): 1st flr business bsmt storage Outdoor Table Service Provided?  Yes  No Delivery of alcohol?  Yes  No

Live Entertainment provided?  Yes  No What Kind (Ex. DJ, Band, Etc.)? N/A Off Premise Catering of Food and Alcohol?  Yes  No

Zoning Receipt or Current Certificate of Occupancy Permit attached to Application?  Yes  No Estimated Seating Capacity: 70

*Please note that as per Alc. Bev. Art. § 12-1407(A)(2), an application for the issuance or transfer, is not complete unless the applicant has obtained approval and/or verification from the Baltimore Municipal Zoning Appeals (BMZA)*

1. Applicant A

Edwin Aguilar [REDACTED] [REDACTED]

(Full name) (Telephone no.) E-mail (Required)

5006 Remmell Avenue Baltimore MD 21206 3 years

(Residence) Street City State Zip Code (period of residency in Baltimore City)

5187 M Guatemala

(Month/Year of Birth) (Sex: Male or Female) (Place of Birth)

Check:  Yes  No Are you currently a resident of the City of Baltimore?

2. Applicant B

Dany Lopez [REDACTED] [REDACTED]

(Full name) (Telephone no.) E-mail (Required)

5006 Remmell Avenue Baltimore MD 21206 3 years

(Residence) Street City State Zip Code (period of residency in Baltimore City)

9/85 M El Salvador

(Month/Year of Birth) (Sex: Male or Female) (Place of Birth)

Check:  Yes  No Are you currently a resident of the City of Baltimore?

3. Applicant C

(Full name) (Telephone no.) E-mail (Required)

(Residence) Street City State Zip Code (period of residency in Baltimore City)

(Month/Year of Birth) (Sex: Male or Female) (Place of Birth)

Check:  Yes  No Are you currently a resident of the City of Baltimore?

1. Has the applicant(s) been adjudged guilty of a felony in the State of Maryland or any other?  Yes  No - If yes, indicate applicant and explain.

Applicant A  B  C

2. Has the applicant(s) been adjudged guilty of violating the laws governing the sale of any alcoholic beverage or for gambling in any State, including Maryland?  Yes  No - If yes, mark applicant and provide explanation in adjacent space provided.

Applicant A  B  C

3. State whether the applicant(s) has ever been adjudged guilty of any offense against the laws of the State of Maryland, any other State within the United States, or against the United States (Federal Crime)?  Yes  No - If yes, mark applicant and explain.

Applicant A  B  C

2010, DUI, Baltimore County Maryland, Probation before Judgment

4. Has the applicant(s) ever had a license for the sale of alcoholic beverages in the State of Maryland?  Yes  No If yes, mark applicant and explain (address of location, dates that the applicant was a licensee, and the trade name).

Applicant A  B  C

A: current licensee since 2019

5. Has the applicant(s) ever had a liquor license suspended or revoked?  Yes  No If yes, mark applicant and explain.

Applicant A  B  C

6. Does the applicant(s) have a financial interest in any other alcoholic beverage business or business for which an alcoholic beverage license has been applied for, granted, and issued?  Yes  No If yes, mark applicant and explain (address of location and trade name).

Applicant A  B  C

7. Do the spouses or dependant children of any of the applicant(s) have a financial interest in any other alcoholic beverages license or business in Baltimore City or any other jurisdiction in the State of Maryland?  Yes  No If yes, mark applicant and explain (address of location and trade name).

Applicant A  B  C

8. Are you financially interested in any other alcoholic beverages license applied, granted or issued?  Yes  No If yes, please explain.

Applicant A  B  C

9. Is the licensed premise currently open and operating?  Yes  No If no, then provide date of last day of operation of the establishment.

10. Do any of the applicant(s) - personally or through an entity - have any indebtedness or other financial obligations to any manufacturer, brewer, distiller, or wholesaler at the time of making this application?  Yes  No If yes, please explain. If yes, please provide information as to the applicant(s) indebted - personally or through an entity - the amount of the indebtedness, and the name of the manufacturer, brewer, distiller, or wholesaler?

Applicant A  B  C

11. Please list the following information for the Manager of the establishment to be licensed:

Name	Address	Phone	Email
Dany Lopez	5006 Remmel Ave	[REDACTED]	[REDACTED]

hotmail.com

Applicants Applying as Business Entities - (Give name(s) and addresses - in Corporation list all officers (attach list if necessary) or in Limited Liability Company/Partnerships list all authorized persons.) *Please note that all licensees MUST have a FINANCIAL INTEREST in the license applied for as per Ab. Gov. Art. 84-109 (a)(10). If necessary, please attach a list of the names and address of all outstanding stock holders who at the time of application own any stock of the corporation and the articles of incorporation, partnership agreement or articles of organization.*

- 1) NAME: Edwin Aguilar ADDRESS: 5006 Remmel Ave 21206 TITLE: co-owner %OF STOCK HELD: 50
- 2) NAME: Dany Lopez ADDRESS: 5006 Remmel Ave 21206 TITLE: co-owner %OF STOCK HELD: 50
- 3) NAME: \_\_\_\_\_ ADDRESS: \_\_\_\_\_ TITLE: \_\_\_\_\_ %OF STOCK HELD: \_\_\_\_\_
- 4) NAME: \_\_\_\_\_ ADDRESS: \_\_\_\_\_ TITLE: \_\_\_\_\_ %OF STOCK HELD: \_\_\_\_\_

*\*Extract from Law: If any affidavit or oath required under the provisions of this Act shall contain any false statements, the offender shall be deemed guilty of perjury. And upon indictment and conviction thereof, shall be subject to penalties provided by Law for that crime.*

**CERTIFICATE OF APPLICANTS:** At least one applicant whose signature appears below certifies that he/she has been a resident and taxpayer of Baltimore City, Maryland for at least two years preceding the filing of this application. Each of said applicants hereby certifies further that if the license applied for is granted, he/she will conform to all State and County laws and regulations relating to the sale of alcoholic beverages, as well as to the rules and regulations of the Board of License Commissioners for Baltimore City, and hereby grants permission to the State Comptroller, his duly authorized deputies, inspectors and clerks, The Board of License Commissioners for Baltimore City, its duly authorized agents and employees, and any peace officer of Baltimore City or the State of Maryland to inspect and search at any and all hours without warrant, the premises and any and all parts thereof upon and in which said business is to be conducted.

[Signature]  
Signature of Applicant A

I hereby certify that on the 26 day of October, 2022, before me, the subscriber, a notary public of the State of Maryland in and for Baltimore City, personally appeared Edwin Aguilar the applicant(s) named in this application made oath in due form of law that the matter and facts contained in said application are true and correct. As witness, my hand and notarial seal.

Signature: [Signature] (Notary Seal) My Commission expires 12/16/22  
Printed Name: Stephan W Feigleman, Jr.

[Signature]  
Signature of Applicant B

I hereby certify that on the 26 day of October, 2022, before me, the subscriber, a notary public of the State of Maryland in and for Baltimore City, personally appeared Dany Lopez the applicant(s) named in this application made oath in due form of law that the matter and facts contained in said application are true and correct. As witness, my hand and notarial seal.

Signature: [Signature] (Notary Seal) My Commission expires 12/16/22  
Printed Name: Stephan W Feigleman, Jr.

Signature of Applicant C

I hereby certify that on the \_\_\_\_\_ day of \_\_\_\_\_, 20\_\_\_\_, before me, the subscriber, a notary public of the State of \_\_\_\_\_ in and for \_\_\_\_\_, personally appeared \_\_\_\_\_ the applicant(s) named in this application made oath in due form of law that the matter and facts contained in said application are true and correct. As witness, my hand and notarial seal.

Signature: \_\_\_\_\_ (Notary Seal) My Commission expires \_\_\_\_\_  
Printed Name: \_\_\_\_\_

Name and Address of the owners of the premise/landlord: Dishol Partners LLC Phone Number: [REDACTED]

**STATEMENT OF OWNER OF PREMISES REQUIRED IN CONNECTION WITH ALCOHOLIC BEVERAGES LAW OF MARYLAND**

(I, WE) Solomon Weldekirstas HEREBY CERTIFY, That (I am, we are) the owner(s) of the property located at 53-55 S. KEESSON ST, Baltimore, City with a Zip Code of 21229, which is named in the present application made to the Board of Liquor License Commissioners of Baltimore City under the Alcoholic Beverage Laws of Maryland and assent to the granting of the license applied for, and hereby authorize the State Comptroller, his duly authorized deputies, inspectors and clerks, the Board of Liquor License Commissioners of Baltimore City, its duly authorized agents and employees, and any peace officer of the City of Baltimore and State of Maryland, to inspect and search, without warrant, the premises upon which the business is to be conducted, and any and all parts of the building in which said business is to be conducted, at any and all hours.

[Signature]  
Signature of Owner of the Property

I hereby certify that on the 22 day of October, 2020, before me, the subscriber, a notary public of the State of Maryland, in and for Baltimore City, personally appeared Solomon Weldekirstas the landlord/property owner named in this application made oath in due form of law that the matter and facts contained in said application are true and correct.

As witness, my hand and notarial seal.

Notary Signature: [Signature]

STEPHAN W. FOGLEMAN, JR.  
NOTARY PUBLIC STATE OF MARYLAND  
My Commission Expires 12/16/22  
[Notary Seal] My Commission expires

Notary Printed Name: Stephan W. Fogelman, Jr.

**The following certificates must be signed by at least 3 persons.**

We, the undersigned citizens, real estate owners and registered voters in the City of Baltimore in which the business covered by the present application is to be conducted. We certify that the qualifying applicant(s) is/are personally known to us and has been a resident or a taxpayer of Baltimore City and a resident of the State of Maryland for 2 years preceding this application.

Names	Address	Signature	DOB (Month/Year)	Length of time Acquainted with the Applicant(s)
<u>Jose E. Ribadeniera</u>	<u>1811 E. LOMBARD ST BALTO. MD. 21231</u>	<u>[Signature]</u>	<u>12-1956</u>	<u>FIVE YEARS</u>
<u>James A. Brees</u>	<u>1045 Edwood Ave Baltimore, MD 21219</u>	<u>[Signature]</u>	<u>91-11-1952</u>	<u>15+ Years</u>
<u>Johanne Steuberg</u>	<u>728 S Clinton St Baltimore, MD 21234</u>	<u>[Signature]</u>	<u>2-1979</u>	<u>2 years</u>

**RECEIVED**  
NOV 12 2020  
BALTIMORE CITY  
BALTIMORE CITY  
LIQUOR BOARD

Board of Liquor License Commissioners for the City of Baltimore  
1 North Charles Street, Suite 1500, Baltimore, Maryland 21201  
Phone: 410-396-4377 Fax: 410-396-4382

Please note that this is a public document and a copy of this document will be provided to the general members of the Board.

Name and Address of the owners of the premise/landlord: \_\_\_\_\_ Phone Number: \_\_\_\_\_

**STATEMENT OF OWNER OF PREMISES REQUIRED IN CONNECTION WITH ALCOHOLIC BEVERAGES LAW OF MARYLAND**

(I, WE) \_\_\_\_\_ HEREBY CERTIFY, That (I am, we are) the owner(s) of the property located at 55 S Kresson St, Baltimore, City with a Zip Code of \_\_\_\_\_, which is named in the present application made to the Board of Liquor License Commissioners of Baltimore City under the Alcoholic Beverage Laws of Maryland and assent to the granting of the license applied for, and hereby authorize the State Comptroller, his duly authorized deputies, inspectors and clerks, the Board of Liquor License Commissioners of Baltimore City, its duly authorized agents and employees, and any peace officer of the City of Baltimore and State of Maryland, to inspect and search, without warrant, the premises upon which the business is to be conducted, and any and all parts of the building in which said business is to be conducted, at any and all hours.

\_\_\_\_\_  
Signature of Owner of the Property

I hereby certify that on the \_\_\_\_\_ day of \_\_\_\_\_, 20\_\_\_\_, before me, the subscriber, a notary public of the State of \_\_\_\_\_, in and for \_\_\_\_\_, personally appeared \_\_\_\_\_ the landlord/property owner named in this application made oath in due form of law that the matter and facts contained in said application are true and correct.

As witness, my hand and notarial seal.

Notary Signature: \_\_\_\_\_ [Notary Seal] My Commission expires \_\_\_\_\_

Notary Printed Name: \_\_\_\_\_

**The following certificates must be signed by at least 3 persons.**

We, the undersigned citizens, real estate owners and registered voters in the City of Baltimore in which the business covered by the present application is to be conducted. We certify that the qualifying applicant(s) is/are personally known to us and is a resident of Baltimore City and a resident of the State of Maryland at the time of this application.

Names	Address	Signature	DOB (Month/Year)	Length of time Acquainted with the Applicant(s)
Alice Kutner	625 S Clinton St	<i>AK</i>	10/1977	2 years

Board of Liquor License Commissioners for the City of Baltimore  
1 North Charles Street, Suite 1500, Baltimore, Maryland 21201  
Phone: 410-396-4377 Fax: 410-396-4382

Please note that this is a public document and upon request will be provided to the general members of the public.

**\*Please present/draw a Floor Plan/Rendering of the Licensed Premises here. If you have a professionally drafted rendering, please attach it to the application.\***

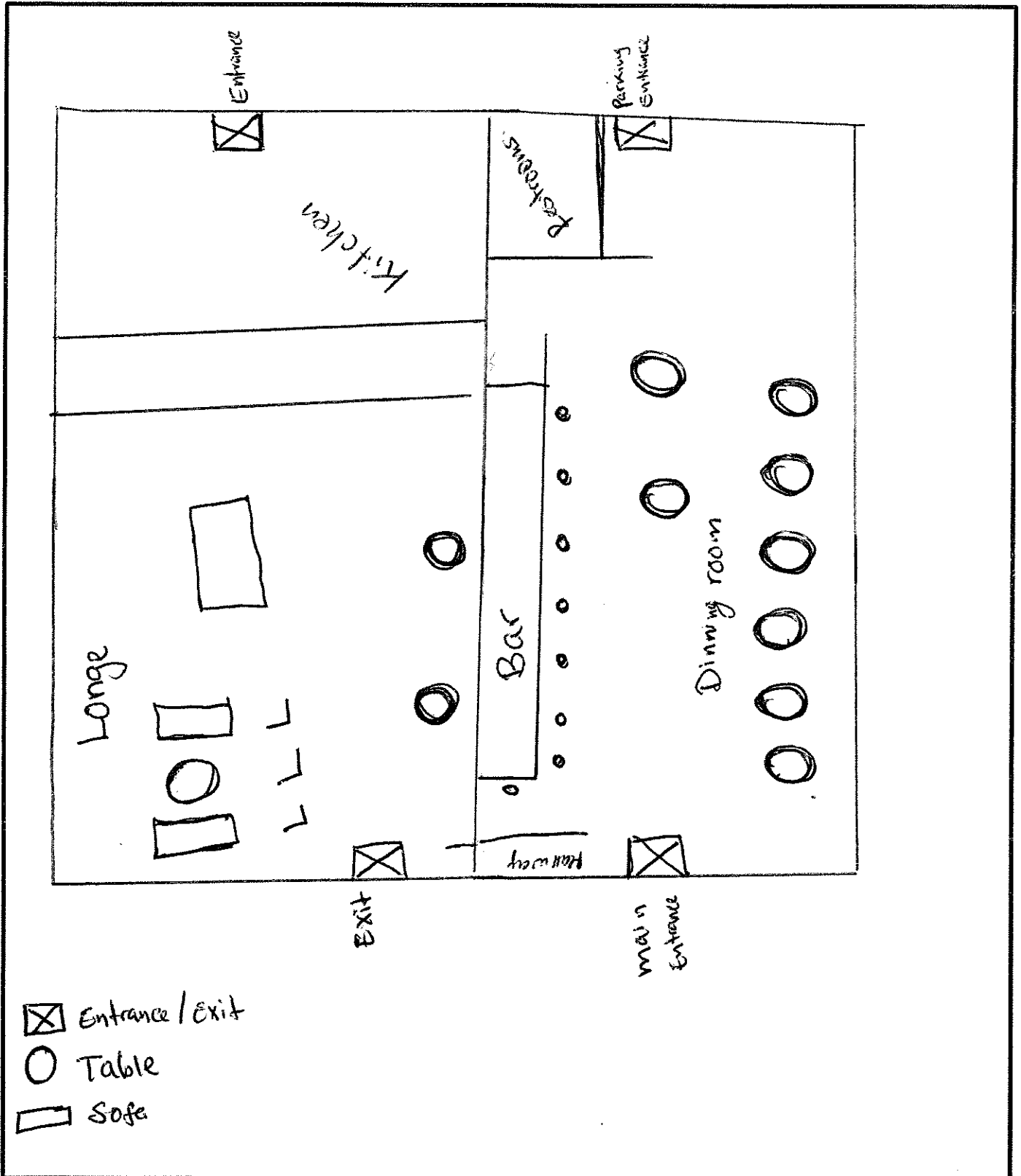



## Liquor Board System

Version 1.0

Annual-Renewal ▼ | License-Transfer ▼ | One-Day ▼ | Add New License ▼ | Query ▼ | Help ▼

### License Detail

#### License Info

License Num: **LBD7 324**      Cert Num: **0864**      Fee: **\$1,320.00**      Status: **Renewed**  
 License Date: 5/1/2021      License Year: 2021  
 CR Number: 16578478  
 Payment Date: 09-01-21

2020 - 2021 TPP Paid   
 2021 Trader's License

[Click to Start License Renewal](#)

### Add Adult Entertainment License

#### Location

Corp Name: **O'RYAN, LLC**  
 Trade Name: **O'RYAN'S PUB**  
 Zone Code: 11  
 Phone: 443-835-3775

Block Num: 53-55      Street: **KRESSON STREET SOUTH**  
 City: **BALTIMORE**      State: **MD**      Zip: **21224**

CR Number: 16578478

Portion of Business Used:  
 USE PREMISES AS A TAVERN/CARRY-OUT AND 1ST FLOOR TAVERN 2ND FLOOR 1  
 DWELLING UNIT 8 ROOMING UNITS REMOVED IN 1987  
 Restriction:

#### License Owners

First Name	Last Name	Street	City	State	Zip	Action	Change Owner
EDWIN	AGUILAR	5006 REMMELL AVENUE	BALTIMORE	MD	21205	<input type="button" value="Edit"/>	<input type="button" value="Remove Owner"/>
SOLOMON	WELDEKIRSTOS	11550 PROSEPCT HILL ROAD	GLENNDAL	MD	20769	<input type="button" value="Edit"/>	<input type="button" value="Remove Owner"/>

#### Comments

--



Date	Comment	Action
07/12/2021	Application for transfer of ownership filed on behalf of O'Ryan, LLC T/a O'Ryan's Pub, Edwin Aguilar and Dany Lopez on 11/2/2020 /kk	Delete
03/22/2021	Letter dated 03/16/2021 Application to Transfer of Ownership was withdrawn Attorney, Steve Fogleman..../sb	Delete
12/17/2020	*****RELEASED STATE OF MD TAX HOLD....***** /mb	Delete
03/13/2020	PAID IN FULL for Violation Hearing dated February 13, 2020; Invoice #119003..../sb	Delete
03/09/2020	Called Attorney for Status on Additional Character Witness names that are still needed for the transfer application submitted to our office on November 12, 2019. Attorney states that he is still trying to get his clients to gather some good names. Advised attorney application is still on hold pending confirmed character witnesses...../jr	Delete
03/03/2020	Given an Invoice to Chief Inspector John for Violation Hearing fee dated on February 13, 2020 Fine Fee to be paid \$625.00.... /mb.	Delete
02/18/2020	2/13/2020 - Public Hearing Re: Violation of Rule 4.05(a)Prohibited Hours and Violation of Rule 4.05(b) Prohibited Hours - Rule 4.05(a)-Admission-Fined \$500; Rule 4.05(b)-Denial-Dismissed, No fine; \$500 + \$125 admin fee; \$625 total fine, 30 days to pay (3-0 vote)..../jr	Delete
01/28/2020	****STATE OF MD TAX HOLD, letter sent to the Business address on January 28, 2020.****/mb	Delete
01/15/2020	Holding Transfer application for change of ownership with licensee's only that the liquor board received on November 12, 2019 and processed payment but did not put in ad. Was not able to process due to needing additional character witnesses. Liquor Board has been in contact with Attorney Cohen on several occasions which is noted on Transfer file and has been advised by attorney that his clients has been unable to get the additional names and that he is staying on top of his clients to come up with the additional character witnesses. Contacted Attorney again today (1/15/2020) and was again advised my Attorney of the same and that the liquor board should hold the application until the end of January and if his clients still have not given any additional names he (the attorney) would come and pick up the application to try and get names himself. Advised atty. that I will continue to hold application along with also reminding him of when the ad for February closes...../jr	Delete
07/24/2019	Alcohol Awareness expires on 07/20/23 Dany Guadalupe Lopez, Edwin S. Aguilar, Maira Guadalupe Reyes and Karla Hojana Martinez (certified by John S Murray)...../sb	Delete
04/30/2019	* Licensee(s) changed during 2019 renewal period - Edwin Aguilar replaced Kibrom Samuel * /kk	Delete
04/29/2019	***** RELEASED STATE TAX HOLD (Dahlak Partners, LLC) ***** /sb	Delete
03/12/2019	*****RELEASED STATE OF MD TAX HOLD*****/mb	Delete
01/25/2019	****STATE OF MD TAX HOLD, letter sent to the Business address on January 25, 2019.****/mb	Delete
01/10/2019	Personal Property Tax Owed to City of Baltimore was cleared as per the email received from Law Department on January 9, 2019..../mb.	Delete
11/23/2018	Personal Property tax letter mailed to Licensee(s) Home Address on 11/20/18../mb.	Delete
03/01/2018	Mailed letter of recognition for underage drinking compliance check on 2/8/2018 /kk	Delete
03/22/2017	*****RELEASED STATE HOLD..... /mb	Delete
02/23/2017	02/23/17 - Public Hearing RE: Application to transfer ownership - APPROVED (3 -0 VOTE)	Delete
01/17/2017	*****STATE OF MD TAX HOLD, letter sent to Licensee on January 17, 2017.***** /sb	Delete
05/06/2015	Alcohol Awareness expies 3/30/2019 ( Lawrence C. O'Donnell)	Delete
10/15/2008	10/14/08 \$100 COMPLIANCE CONF.FEE PAID IN FULL #65151	Delete

Print History (Print Card)

License num: LBD7 324

Address: 53-55 KRESSON STREET SOUTH

Trade Name: O'RYAN'S PUB

Comment:

Add Comment

## O'RYAN, LLC: W17494113

**Department ID Number:**

W17494113

**Business Name:**

O'RYAN, LLC

**Principal Office:** ⓘ

55 S. KRESSON ST  
BALTIMORE MD 21224

**Resident Agent:** ⓘ

SOLOMON WELDEKIRSTOS  
53 S KRESSON ST  
BALTIMORE MD 21224

**Status:**

ACTIVE

**Good Standing:**

THIS BUSINESS IS IN GOOD STANDING

**Business Type:**

DOMESTIC LLC

**Business Code:**

20 ENTITIES OTHER THAN CORPORATIONS

**Date of Formation/ Registration:**

09/14/2016

**State of Formation:**

MD

**Stock Status:**

N/A

**Close Status:**

N/A

PROPOSED LOCATION: 53.55 S. Kresson St

### MAP SUMMARY (RECAPITULATION)

TOTAL ESTABLISHMENTS IN MAP AREA 8

"A" BEER & WINE \_\_\_\_\_

"B" BEER & WINE \_\_\_\_\_

"C" BEER & WINE \_\_\_\_\_

"D" BEER & WINE \_\_\_\_\_

"A" BEER, WINE & LIQUOR \_\_\_\_\_

"A-2" BEER, WINE & LIQUOR \_\_\_\_\_

"B" BEER, WINE & LIQUOR 2

"C" BEER, WINE & LIQUOR \_\_\_\_\_

"D" BEER, WINE & LIQUOR 2

"BD7" BEER, WINE & LIQUOR 4

ARENA \_\_\_\_\_

HOTEL/MOTEL \_\_\_\_\_

RACING \_\_\_\_\_

PREPARED BY: A. Perez DATE: 9/7/21



### Board of Liquor License Commissioners

For Baltimore City  
1 North Charles Street, 15th Floor  
Baltimore, Maryland, 21201

## INSPECTORS REPORT - TRANSFERS/NEW APPLICATIONS

<i>Licensee Information (Trade Name):</i>	O'Ryans Pub
<i>Corporation Name:</i>	O'Ryan, LLC
<i>Location Address:</i>	53-55 . Kresson St
<i>License Type:</i>	Class "BD7" Beer, Wine and Liquor
<i>Is the establishment open and operating in a safe and sanitary manner? (If not open, not in comments - CLOSED or NOT OPERATING)</i>	Yes
<i>Is the location within 300 feet of Church and/or School?</i>	No
<i>Date Posted?</i>	9/1/2021
<i>Estimated Date of Removal?</i>	9/10/2021
<i>Are there any other licensed establishments within a two block radius?</i>	Yes

*Other licensed locations - Describe/Note:*

see attached map

*Comments and Follow-up Items(s) (please note any issues or concerns about the location):*

Application filed for transfer of ownership

*Insert Photo of Sign and location:*

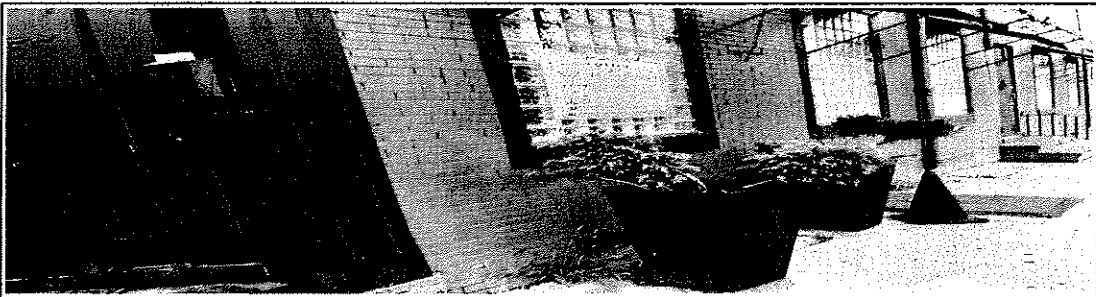

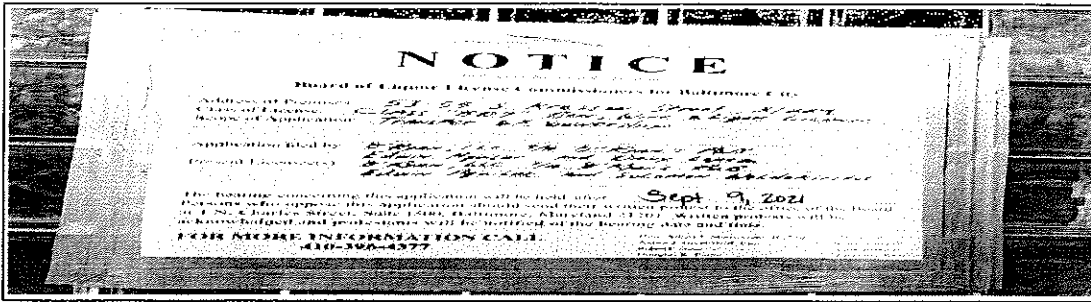

Inspector Name		Date and Time	
i:\O#w\baltimore\andy.perez		9/8/2021	12:26:30 AM
Name of Licensee (if present)			

### Board of Liquor License Commissioners

For Baltimore City  
1 North Charles Street, 15th Floor  
Baltimore, Maryland, 21201

### POSTING SIGNS REPORT

<i>Applicant(s) Name:</i>	Edwin Aguilar, Dany Lopez
<i>Address of Premises:</i>	53-55 S. Kresson St
<i>Inspector:</i>	i:0#w baltimore\andy.perez
<i>Date Posted:</i>	9/1/2021
<i>Time Posted:</i>	
<i>Date Rechecked:</i>	9/13/2021
<i>Time Rechecked:</i>	
<i>Manager or Owner when sign posted:</i>	

*Summary on location of sign posted:*

Sign posted on side window

*Summary on location of sign rechecked:*

Sign remained as posted for the required 10 days period.

*Insert Photo of Sign and location:*

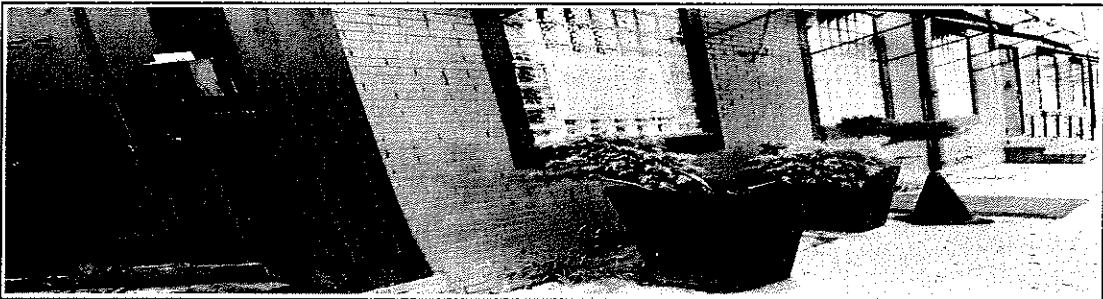

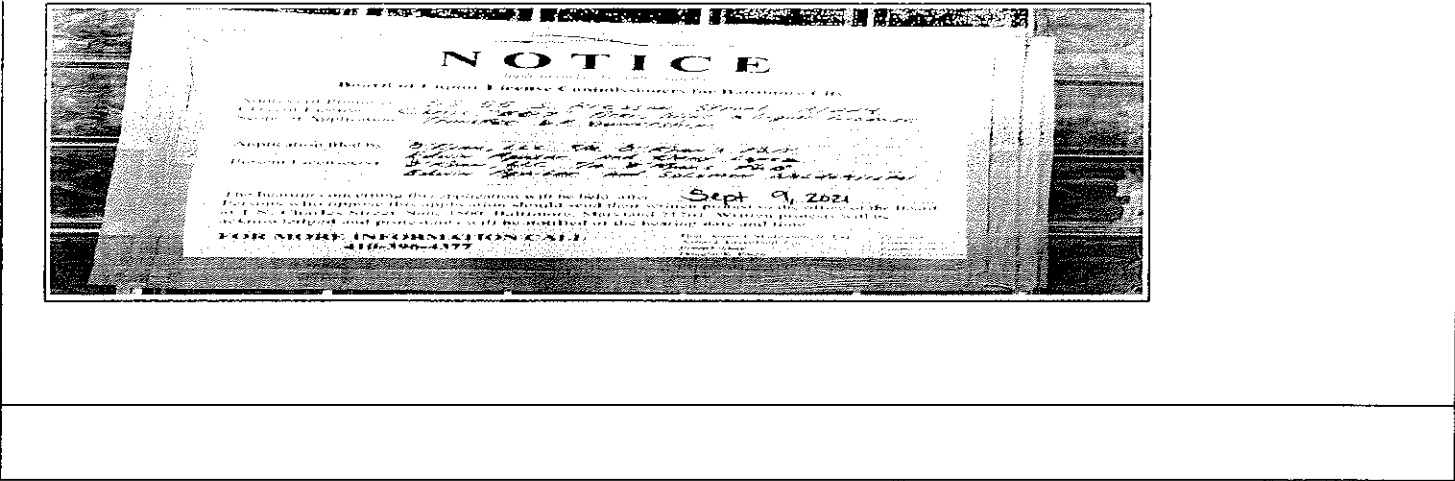



# NOTICE

*Application has been filed with the*

## Board of Liquor License Commissioners for Baltimore City

Address of Premises: 53-55 S. Kresson Street A1224  
Class of License: CLASS "BD7" Beer, Wine & Liquor License  
Scope of Application: TRANSFER OF OWNERSHIP

Application filed by: O'RYAN, LLC TA O'RYAN'S PUB  
Edwin Aguilar and Dany Lopez  
Present Licensee(s): O'RYAN, LLC TA O'RYAN'S PUB  
Edwin Aguilar and Solomon Woldemirstos

The hearing concerning this application will be held after Sept 9, 2021  
Persons who oppose this application should send their written protest to the office of the Board  
at 1 N. Charles Street, Suite 1500, Baltimore, Maryland 21201. Written protests will be  
acknowledged and protestants will be notified of the hearing date and time.

**FOR MORE INFORMATION CALL**  
**410-396-4377**

Hon. Albert J. Matteduciani, Jr., Esq. *Chairman*  
Aaron J. Greenfield, Esq. *Commissioner*  
Robert E. Gaye *Commissioner*  
Douglas K. Paige *Executive Secretary*

# BLLC Routine Inspection

Address: 53-55 KRESSON STREET SOUTH 21224

Trade Name:

Corporation Name:

Type of License: Class "BD7" Beer, Wine and Liquor

Date/Time of Inspection:

Manager/Licensee:

### Operational Status

Open/Closed: Open

Closed Date:

### Sanitation

Clean and Free of Debris: Satisfactory

### Bar Area

Location of Bar: Front

Shape of Bar:

Condition of Bar Area/Floors: Satisfactory

Hot Water: Yes

Disinfectant Solution: Yes

Three Compartment/Washer: Yes

### Package Goods/BD7 Checklist

Bulletproof Partitioning: N/A

Separate Pkg. Goods Dept.: N/A

Separate Pkg. Goods Store: N/A

Bar/Tavern Open and Operating: Yes

Selling Household/Grocery: N/A

Capacity:

Location of Dining Area:

Condition of Dining Area/Floors: Satisfactory

Sanitation: Satisfactory

Menu: Yes

Traders License: No

Alcohol Awareness Certification Date Issued: 7/20/2019

Employee Records: Yes

Alcohol Beverage Information Invoice Numbers and Date:

Inspector Comments:

Inspector Comments:

Public Safety

Exits Marked, Unobstructed: Yes

Fire Capacity:

Outdoor Seating Capacity:

Adult Entertainment - If Applicable

License is Valid:

N/A

*Dancers Present 18 and older:* N/A

*Cleanliness of Dressing Room:* N/A

*Live Entertainment (Describe):*

*Outdoor Table Service* N/A

*Violation Issued:* No

*Violations Noted:*

*Instructions Given to Licensee:*

*Must provide updated business records*

*Inspector's Comments:*

*Health 10/08/2021  
Inspected on 07/30/2021 with the SCTF*

*Photo Taken:*

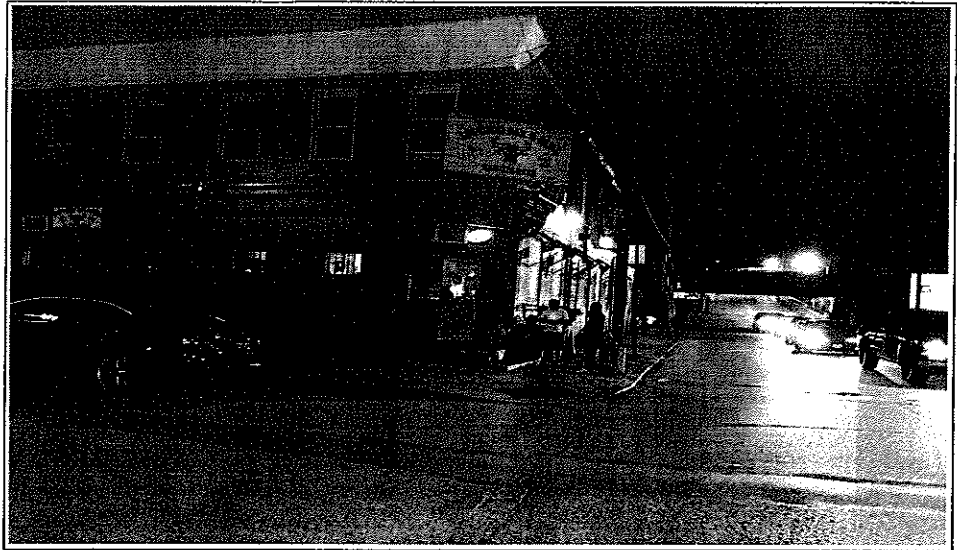

Owner Email:

Submitted by Inspector

# Certificate of Occupancy

THIS WRITTEN INSTRUMENT, WHEN PROPERLY VALIDATED, CONSTITUTES AUTHORITY FOR DOING OR RECEIVING THE THINGS INDICATED BY THE FEES OR CHARGES SHOWN IN THE APPROPRIATE SPACES BELOW. ANY AND ALL THINGS TO BE DONE OR RECEIVED UNDER THIS WRITTEN INSTRUMENT SHALL BE DONE OR RECEIVED IN STRICT COMPLIANCE WITH THE APPLICATION SUBMITTED AND FILED IN THIS DEPARTMENT FOR THE AUTHORITY CONTAINED HEREIN INCLUDING ANY AND ALL APPROVED DRAWINGS AND OTHER DATA OR INFORMATION ATTACHED HERETO, AND SUBJECT TO ANY AND ALL LAWS, ORDINANCES, RULES AND REGULATIONS IN EFFECT IN THE CITY OF BALTIMORE AND THE STATE OF MARYLAND. WARNING: IT IS UNLAWFUL TO WORK BETWEEN THE HOURS OF 7:00 PM AND 7:00 AM WITHIN THE CITY OF BALTIMORE.

WARNING: IT IS UNLAWFUL TO CONCEAL ANY WORK UNTIL INSPECTED AND APPROVED BY THIS DEPARTMENT.

WARD	SEC.	BLOCK	LOT	ISSUE DATE	DISTRICT
26	18	6242	060	11/23/16	202

PROPERTY ADDRESS: 53 S KRESSON ST

OWNER: LAWRENCE O'DONNELL ADDR: 53 S. KRESSON ST BALTIMORE MD

LESSEE: ADDR:

LAND USE CODES 1113 1113 5823 0000

USE PREMISES AS A TAVERN/CARRY-OUT AND 1 FAMILY 1ST FLOOR TAVERN 2ND FLOOR 1 DWELLING UNIT 8 ROOMING UNITS REMOVED IN 1987

1001-00000-2600-15800-00000 PERMITS	1001-00000-2600-15800-00000 MISC	1001-00000-2600-15800-00000 CH USE	1001-00000-2600-15800-00000 NEW BLDG	1001-00000-2600-15800-00000 D ADDITIONS
		45.00		
1001-00000-2600-15800-00000 ALTERATIONS	1001-00000-2600-15800-00000 REPAIRS	1001-00000-2600-15800-00000 MISC - CONSI	1001-00000-2600-15800-00000 ELECT	1001-00000-2600-15800-00000 HYDRO-PNEUMATIC
1001-00000-2600-15800-00000 DISMISAL-FEE	1001-00000-2600-15800-00000 ALL COND	1001-00000-2600-15800-00000 DISP - TAXES	1001-00000-2600-15800-00000 DPI	1001-00000-2600-15800-00000 FUEL-BURNING EQUIPMENT
1001-00000-2600-15800-00000 ELEVATOR	1001-00000-2600-15800-00000 PLUMBING	0.00	1001-00000-2600-15800-00000 S & I CONCRET	1001-00000-2600-15800-00000 TAX
1001-00000-2600-15800-00000 RAZING	1001-00000-2600-15800-00000 BUILDING	50.00	1001-00000-2600-15800-00000 DW-VOLTAIR TELECOMMUNICATIONS	1001-00000-2600-15800-00000 PENALTY
				3.00
				98.00

THE AUTHORITY CONTAINED HEREIN MAY NOT BE VALIDLY EXERCISED UNTIL AND AFTER ALL OF THE FEES APPEARING HEREON HAVE BEEN PAID AND EVIDENCE THEREOF APPEARS IN THIS SPACE.



*Michael Braverman*  
 MICHAEL BRAVERMAN  
 BUILDING OFFICIAL

Please be advised that there is a presumption of lead-based paint in properties constructed prior to 1950. Protect workers and tenants by using the lead-safe work practices found in the Code of Maryland Regulations Section 26.02.07.

THE AUTHORITY CONTAINED HEREIN DOES NOT AUTHORIZE THE PERFORMANCE OF ANY WORK IN, ON, UNDER OR OVER ANY STREET, HIGHWAY, ALLEY, SIDEWALK OR ANY OTHER PUBLIC WAY, UNLESS PERMISSION TO DO SO HAS BEEN FIRST SECURED FROM THE PROPER AUTHORITY.

September 30, 2021

**Applicant(s):** Kynnee Sashae Decator  
Door 61, LLC, T/a Trade Name Pending  
2021 Maryland Avenue 21218

**Class:** "B" Beer, Wine & Liquor License

Application for a new Class "B" Beer, Wine and Liquor restaurant license, requesting outdoor table service and off-premise catering.

(a) **Applicant(s) Information:** (1) Kynnee Sashae Decator was born in Baltimore, MD in January of 1989. She lives in Baltimore, MD.

(b) **Ownership Breakdown:** (1) Kynnee Sashae Decator (100%).

(c) **Purchase Price of Business:** N/A

(d) **Qualified Voters:** Elijah Kelley, Raynell Smoot and Melody Ricks are qualified Baltimore City voters.

(e) **Zoning:** Applicant has applied for a USE permit, for the use of premise as a tavern with live entertainment, retail space and outdoor dining approved via BMZA 2019-394. Subject to continued compliance with the conditions stated in appeal 2019-394.

(f) **Corporate Standing:** Door 61, LLC is a MD LLC and as of 9/14/2021 is active and in good standing.

(g) **Posting Report:** The location was posted on 8/25/2021, and will be checked on 9/3/2021. This meets the 10-day rule. There are 9 licensed liquor establishment(s) in the 2x2 area "B" BW-8; and "A" BWL-1.

(h) **Timeline:** N/A

(i) **Letters of Support/Opposition:** At this time the Board has no letter(s) of opposition or support.

In considering this request, under the provisions of Alcohol Beverages Article 4-210(A) the Board must consider the following factors: 1. The public need and desire for the license; 2. The number and location of existing license holders; 3. The potential effect on existing license holders of the license for which application is made; 4. The potential commonality or uniqueness of the services and products to be offered by the business of the applicant; 5. The impact of the license for which application is made on the health, safety, and welfare of the community, including issues relating to crime, traffic conditions, parking, or convenience; and 6. Any other factor that the local licensing Board considers necessary.

**Board's Decision:**

# 2020 Application for Alcoholic Beverages License Board of Liquor License Commissioners for Baltimore City

NEW/TRANSFER/EXPANSION/AMENDMENT(S) APPLICATION FEE - \$600.00

INDICATE TYPE OF LICENSE APPLICATION: TRANSFER  NEW  EXPANSION OF PREMISES  AMENDMENT(S)

EXPLANATION OF REQUEST: New Restaurant License, CLASS TYPE: B

*Please select one option and fill out the requested information*

A) NEW LICENSE REQUEST: ADDRESS OF PROPOSED LOCATION: 2021 Maryland Ave, Baltimore 21218

B) TRANSFER OF OWNERSHIP ONLY: ADDRESS OF CURRENT LICENSE: \_\_\_\_\_

C) TRANSFER OF OWNERSHIP AND LOCATION: CURRENT ADDRESS OF LICENSED LOCATION: \_\_\_\_\_  
 TRANSFER OF OWNERSHIP AND LOCATION: ADDRESS OF PROPOSED RELOCATION: \_\_\_\_\_

D) AMENDMENT OR EXPANSION REQUEST: ADDRESS OF THE LOCATION: \_\_\_\_\_

---

CORPORATE/LLC/LLP/PARTNERSHIP NAME: Door 61, LLC TRADE NAME: pending

BUSINESS PHONE NUMBER: 202 751 7452 BUSINESS EMAIL ADDRESS: info@door61lounge.com

ATTORNEY FOR THE APPLICANT: A L Hurdle, Esq. ADDRESS: 320 N Charles St PHONE: 410 685 5100

Part of Premises Used (Note: Floors and Areas for Storage): First, basement Outdoor Table Service Provided?  Yes  No Delivery of alcohol?  Yes  No  
 Live Entertainment provided?  Yes  No What Kind (Ex. DJ, Band, Etc.)? \_\_\_\_\_ Off Premise Catering of Food and Alcohol?  Yes  No  
 Zoning Receipt or Current Certificate of Occupancy Permit attached to Application?  Yes  No Estimated Seating Capacity: 80+

YES FWH HOC

*Please note that as per Alc. Bev. Art. 8-12-1407(A)(2), an application for the issuance or transfer, is not complete unless the applicant has obtained approval and/or verification from the Baltimore Municipal Zoning Appeals (BMZA)*

### 1. Applicant A

Kynnee Sashae Decator  
 (Full name) \_\_\_\_\_ (Telephone no.) \_\_\_\_\_ E-mail (Required) \_\_\_\_\_  
 5502 Price Ave Baltimore MD 21215 32 yrs.  
 (Residence) Street City State Zip Code (period of residency in Baltimore City)  
 1/1989 Female Baltimore MD  
 (Month/Year of Birth) (Sex: Male or Female) (Place of Birth)  
 Check:  Yes  No Are you currently a resident of the City of Baltimore?

### 2. Applicant B

\_\_\_\_\_  
 (Full name) \_\_\_\_\_ (Telephone no.) \_\_\_\_\_ E-mail (Required) \_\_\_\_\_  
 \_\_\_\_\_ City State Zip Code (period of residency in Baltimore City)  
 \_\_\_\_\_ (Month/Year of Birth) (Sex: Male or Female) (Place of Birth)  
 Check:  Yes  No Are you currently a resident of the City of Baltimore?

### 3. Applicant C

\_\_\_\_\_  
 (Full name) \_\_\_\_\_ (Telephone no.) \_\_\_\_\_ E-mail (Required) \_\_\_\_\_  
 \_\_\_\_\_ City State Zip Code (period of residency in Baltimore City)  
 \_\_\_\_\_ (Month/Year of Birth) (Sex: Male or Female) (Place of Birth)  
 Check:  Yes  No Are you currently a resident of the City of Baltimore?



1. Has the applicant(s) been adjudged guilty of a felony in the State of Maryland or any other?  Yes  No - If yes, indicate applicant and explain.  
Applicant A  B  C

2. Has the applicant(s) been adjudged guilty of violating the laws governing the sale of any alcoholic beverage or for gambling in any State, including Maryland?  Yes  No - If yes, mark applicant and provide explanation in adjacent space provided.

Applicant A  B  C

3. State whether the applicant(s) has ever been adjudged guilty of any offense against the laws of the State of Maryland, any other State within the United States, or against the United States (Federal Crime)?  Yes  No - If yes, mark applicant and explain.

Applicant A  B  C

4. Has the applicant(s) ever had a license for the sale of alcoholic beverages in the State of Maryland?  Yes  No If yes, mark applicant and explain (address of location, dates that the applicant was a licensee, and the trade name).

Applicant A  B  C

5. Has the applicant(s) ever had a liquor license suspended or revoked?  Yes  No If yes, mark applicant and explain.

Applicant A  B  C

6. Does the applicant(s) have a financial interest in any other alcoholic beverage business or business for which an alcoholic beverage license has been applied for, granted, and issued?  Yes  No If yes, mark applicant and explain (address of location and trade name).

Applicant A  B  C

7. Do the spouses or dependent children of any of the applicant(s) have a financial interest in any other alcoholic beverages license or business in Baltimore City or any other jurisdiction in the State of Maryland?  Yes  No If yes, mark applicant and explain (address of location and trade name).

Applicant A  B  C

8. Are you financially interested in any other alcoholic beverages license applied, granted or issued?  Yes  No If yes, please explain.

Applicant A  B  C

9. Is the licensed premise currently open and operating?  Yes  No If no, then provide date of last day of operation of the establishment.

new "B" B,W,L

10. Do any of the applicant(s) - personally or through an entity - have any indebtedness or other financial obligations to any manufacturer, brewer, distiller, or wholesaler at the time of making this application?  Yes  No If yes, please explain. If yes, please provide information as to the applicant(s) indebted - personally or through an entity - the amount of the indebtedness, and the name of the manufacturer, brewer, distiller, or wholesaler?

Applicant A  B  C

II. Please list the following information for the Manager of the establishment to be licensed:

Name	Address	Phone	Email

Applicants Applying as Business Entities - (Give name(s) and addresses - in Corporation list all officers (attach list if necessary) or in Limited Liability Company/Partnerships list all authorized persons.) *Please note that all licensees MUST have a FINANCIAL INTEREST in the license applied for as per Alc. Bev. Art. § 4-109 (a)(11). If necessary, please attach a list of the names and address of all outstanding stock holders who at the time of application own any stock of the corporation and the articles of Incorporation, partnership agreement or articles of organization.*

- 1) NAME: Kynnee S. Decator ADDRESS: 5502 Price Ave TITLE: Sole Member %OF STOCK HELD: 100%  
 2) NAME: \_\_\_\_\_ ADDRESS: \_\_\_\_\_ TITLE: \_\_\_\_\_ %OF STOCK HELD: \_\_\_\_\_  
 3) NAME: \_\_\_\_\_ ADDRESS: \_\_\_\_\_ TITLE: \_\_\_\_\_ %OF STOCK HELD: \_\_\_\_\_  
 4) NAME: \_\_\_\_\_ ADDRESS: \_\_\_\_\_ TITLE: \_\_\_\_\_ %OF STOCK HELD: \_\_\_\_\_

*\*Extract from Law: If any affidavit or oath required under the provisions of this Act shall contain any false statements, the offender shall be deemed guilty of perjury. And upon indictment and conviction thereof, shall be subject to penalties provided by Law for that crime.*

**CERTIFICATE OF APPLICANTS:** At least one applicant whose signature appears below certifies that he/she is a current resident of Baltimore City, Maryland at the time of filing of this application. Each of said applicants hereby certifies further that if the license applied for is granted, he/she will conform to all State and County laws and regulations relating to the sale of alcoholic beverages, as well as to the rules and regulations of the Board of License Commissioners for Baltimore City, and hereby grants permission to the State Comptroller, his duly authorized deputies, inspectors and clerks, The Board of License Commissioners for Baltimore City, its duly authorized agents and employees, and any peace officer of Baltimore City or the State of Maryland to inspect and search at any and all hours, without warrant, the premises and any and all parts thereof upon and in which said business is to be conducted. If license is issued, the applicants must ensure that at least one licensee remains a resident of Baltimore City throughout the duration of this license.

[Signature]  
 Signature of Applicant A

I hereby certify that on the 28<sup>th</sup> day of April, 2021, before me, the subscriber, a notary public of the State of Maryland in and for Balto. Co., personally appeared Kynnee S. Decator the applicant(s) named in this application made oath in due form of law that the matter and facts contained in said application are true and correct. As witness, my hand and notarial seal.

Signature: Elaine Pappas (Notary Seal) My Commission expires 11/19/2022  
 Printed Name: Elaine Pappas



Signature of Applicant B

I hereby certify that on the \_\_\_\_\_ day of \_\_\_\_\_, 20\_\_\_\_, before me, the subscriber, a notary public of the State of \_\_\_\_\_ in and for \_\_\_\_\_, personally appeared \_\_\_\_\_ the applicant(s) named in this application made oath in due form of law that the matter and facts contained in said application are true and correct. As witness, my hand and notarial seal.

Signature: \_\_\_\_\_ (Notary Seal) My Commission expires \_\_\_\_\_  
 Printed Name: \_\_\_\_\_

Signature of Applicant C

I hereby certify that on the \_\_\_\_\_ day of \_\_\_\_\_, 20\_\_\_\_, before me, the subscriber, a notary public of the State of \_\_\_\_\_ in and for \_\_\_\_\_, personally appeared \_\_\_\_\_ the applicant(s) named in this application made oath in due form of law that the matter and facts contained in said application are true and correct. As witness, my hand and notarial seal.

Signature: \_\_\_\_\_ (Notary Seal) My Commission expires \_\_\_\_\_  
 Printed Name: \_\_\_\_\_

Name and Address of the owners of the premise/landlord: Elijah L. Kelley  
100 Harborview Dr, Ste. 405 Phone Number:   
Balto, MD 21230

**STATEMENT OF OWNER OF PREMISES REQUIRED IN CONNECTION WITH ALCOHOLIC BEVERAGES LAW OF MARYLAND**

(I, WE) Elijah L. Kelley HEREBY CERTIFY,  
 That (I am, we are) the owner(s) of the property located at 2021 Maryland Ave, Baltimore, City with a Zip  
 Code of 21218, which is named in the present application made to the Board of Liquor License Commissioners of Baltimore City  
 under the Alcoholic Beverage Laws of Maryland and assent to the granting of the license applied for, and hereby authorize the State Comptroller, his  
 duly authorized deputies, inspectors and clerks, the Board of Liquor License Commissioners of Baltimore City, its duly authorized agents and  
 employees, and any peace officer of the City of Baltimore and State of Maryland, to inspect and search, without warrant, the premises upon which  
 the business is to be conducted, and any and all parts of the building in which said business is to be conducted, at any and all hours.

  
 Signature of Owner of the Property

I hereby certify that on the 28<sup>th</sup> day of April, 2021, before me, the subscriber, a notary public of the State of Maryland, in and  
 for Balto. Co., personally appeared Elijah L. Kelley the  
 landlord/property owner named in this application made oath in due form of law that the matter and facts contained in said application are true and correct.

As witness, my hand and notarial seal.

Notary Signature: Elaine Pappas (Notary Seal) My Commission expires 11/19/2022  
 Notary Printed Name: Elaine Pappas

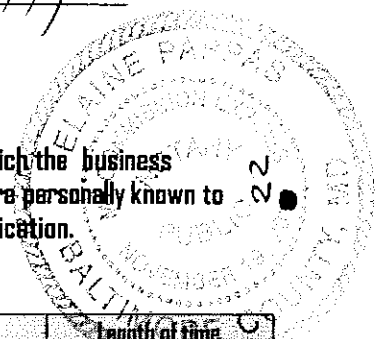

**The following certificates must be signed by at least 3 persons.**

We, the undersigned citizens, real estate owners and registered voters in the City of Baltimore in which the business  
 covered by the present application is to be conducted. We certify that the qualifying applicant(s) is/are personally known to  
 us and is a resident of Baltimore City and a resident of the State of Maryland at the time of this application.

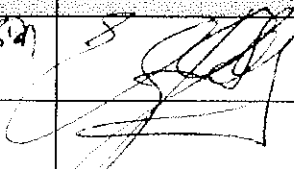
Names	Address	Signature	DOB (Month/Year)	Length of time Acquainted with the Applicant(s)
<u>Elijah Kelley</u>	<u>506 N. Paxson St</u>		<u>1/73</u>	<u>3 YEARS</u>

Board of Liquor License Commissioners for the City of Baltimore  
 1 North Charles Street, Suite 1500, Baltimore, Maryland 21201  
 Phone: 410-396-4377 Fax: 410-396-4382

Please note that this is a public document and upon request  
 will be provided to the general members of the public.

re: 2021 Maryland Ave; 21218

Name and Address of the owners of the premise/landlord: \_\_\_\_\_ Phone Number: \_\_\_\_\_

**STATEMENT OF OWNER OF PREMISES REQUIRED IN CONNECTION WITH ALCOHOLIC BEVERAGES LAW OF MARYLAND**

(I, WE) \_\_\_\_\_ HEREBY CERTIFY, That (I am, we are) the owner(s) of the property located at \_\_\_\_\_, Baltimore, City with a Zip Code of \_\_\_\_\_, which is named in the present application made to the Board of Liquor License Commissioners of Baltimore City under the Alcoholic Beverage Laws of Maryland and assent to the granting of the license applied for, and hereby authorize the State Comptroller, his duly authorized deputies, inspectors and clerks, the Board of Liquor License Commissioners of Baltimore City, its duly authorized agents and employees, and any peace officer of the City of Baltimore and State of Maryland, to inspect and search, without warrant, the premises upon which the business is to be conducted, and any and all parts of the building in which said business is to be conducted, at any and all hours.

Signature of Owner of the Property \_\_\_\_\_

I hereby certify that on the \_\_\_\_\_ day of \_\_\_\_\_, 20\_\_\_\_, before me, the subscriber, a notary public of the State of \_\_\_\_\_, in and for \_\_\_\_\_, personally appeared \_\_\_\_\_ the landlord/property owner named in this application made oath in due form of law that the matter and facts contained in said application are true and correct.

As witness, my hand and notarial seal.

Notary Signature: \_\_\_\_\_ [Notary Seal] My Commission expires \_\_\_\_\_

Notary Printed Name: \_\_\_\_\_

**The following certificates must be signed by at least 3 persons.**

We, the undersigned citizens, real estate owners and registered voters in the City of Baltimore in which the business covered by the present application is to be conducted. We certify that the qualifying applicant(s) is/are personally known to us and is a resident of Baltimore City and a resident of the State of Maryland at the time of this application.

Names	Address	Signature	DOB (Month/Year)	Length of time Acquainted with the Applicant(s)
Raynell Smart	438 S. August Ave Balti, MD 21229		1967 08/1967	32 years
Dawon Jackson	1837 Pennsylvania Ave, Balti, MD 21217		03/1982	8 years
Melody RICKS	4426 Firney Ave Balti, MD 21215		02/1958	32 years
Detra LUCK	607 Cator Ave Balti, MD 21218		03/1972	8 years

Board of Liquor License Commissioners for the City of Baltimore  
1 North Charles Street, Suite 1500, Baltimore, Maryland 21201  
Phone: 410-396-4377 Fax: 410-396-4382

Please note that this is a public document and upon request will be provided to the general members of the public.

\*Please present/draw a Floor Plan/Rendering of the Licensed Premises here. If you have a professionally drafted rendering, please attach it to the application.\*

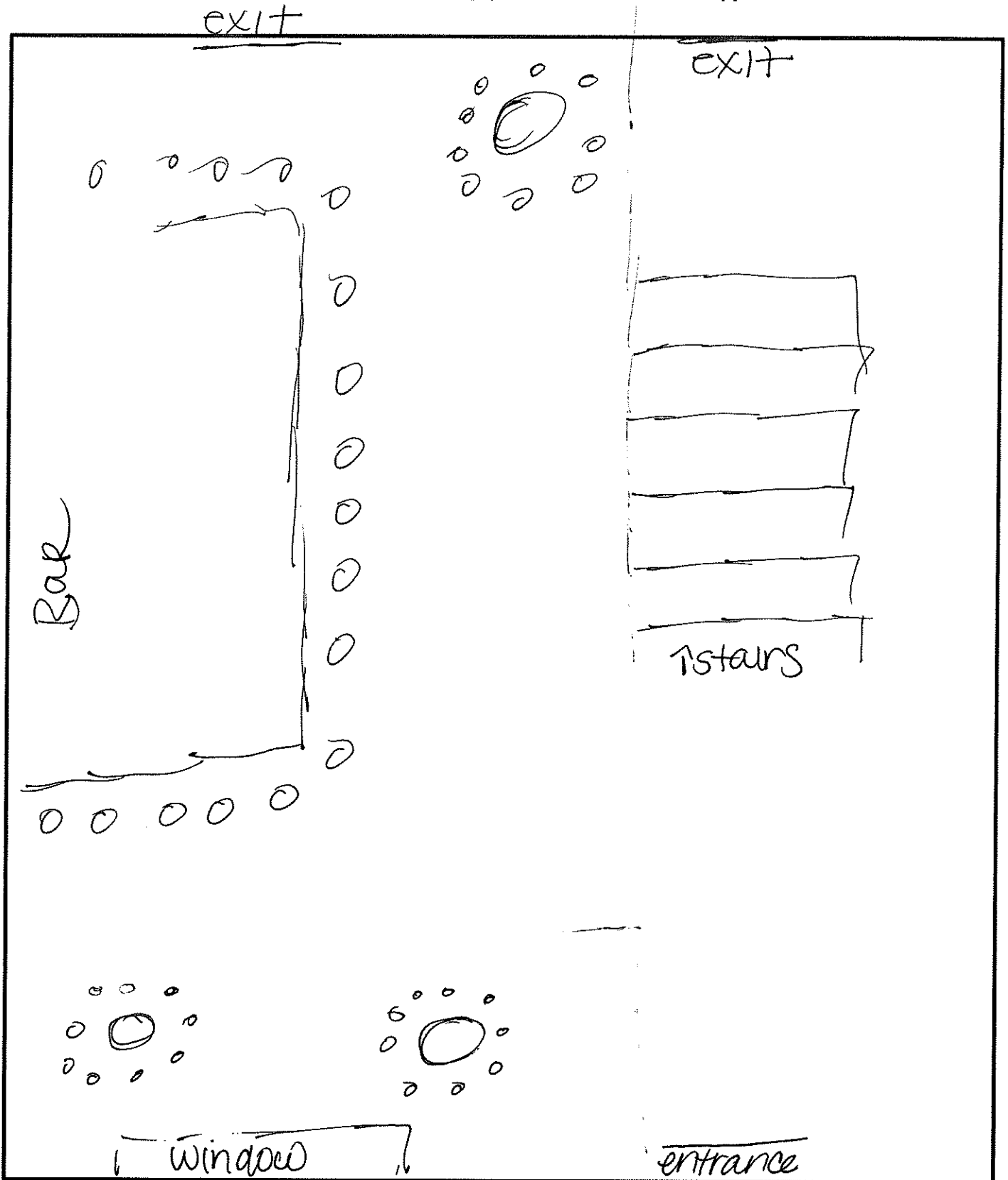

## DOOR 61 LLC: W21376132

**Department ID Number:**

W21376132

**Business Name:**

DOOR 61 LLC

**Principal Office:** ⓘ

2021 MARYLAND AVE

BALTIMORE MD 21218

**Resident Agent:** ⓘ

KYNNEE DECATOR

5502 PRICE AVE

BALTIMORE MD 21215

**Status:**

ACTIVE

**Good Standing:**

THIS BUSINESS IS IN GOOD STANDING

**Business Type:**

DOMESTIC LLC

**Business Code:**

20 ENTITIES OTHER THAN CORPORATIONS

**Date of Formation/ Registration:**

01/31/2021

**State of Formation:**

MD

**Stock Status:**

N/A

**Close Status:**

N/A

PROPOSED LOCATION: 2021 Maryland Ave

### MAP SUMMARY (RECAPITULATION)

TOTAL ESTABLISHMENTS IN MAP AREA 9

"A" BEER & WINE \_\_\_\_\_

"B" BEER & WINE 8

"C" BEER & WINE \_\_\_\_\_

"D" BEER & WINE \_\_\_\_\_

"A" BEER, WINE & LIQUOR 1

"A-2" BEER, WINE & LIQUOR \_\_\_\_\_

"B" BEER, WINE & LIQUOR \_\_\_\_\_

"C" BEER, WINE & LIQUOR \_\_\_\_\_

"D" BEER, WINE & LIQUOR \_\_\_\_\_

"BD7" BEER, WINE & LIQUOR \_\_\_\_\_

ARENA \_\_\_\_\_

HOTEL/MOTEL \_\_\_\_\_

RACING \_\_\_\_\_

PREPARED BY: Darryl Clark DATE: 8/30/21

# 2021 Maryland Ave - LB

## Liquor Licensed Establishments

- 📍 Joung Kak LB
- 📍 The Crown Baltimore LB
- 📍 Mi Comalito LB
- 📍 BeOne Korean BBQ Rest LB
- 📍 Beatnik Bar LB
- 📍 iBar LB
- 📍 Nam Kang LB
- 📍 Geri's Liquors LA
- 📍 2021 Maryland Ave
- 📍 No Land Beyond LB

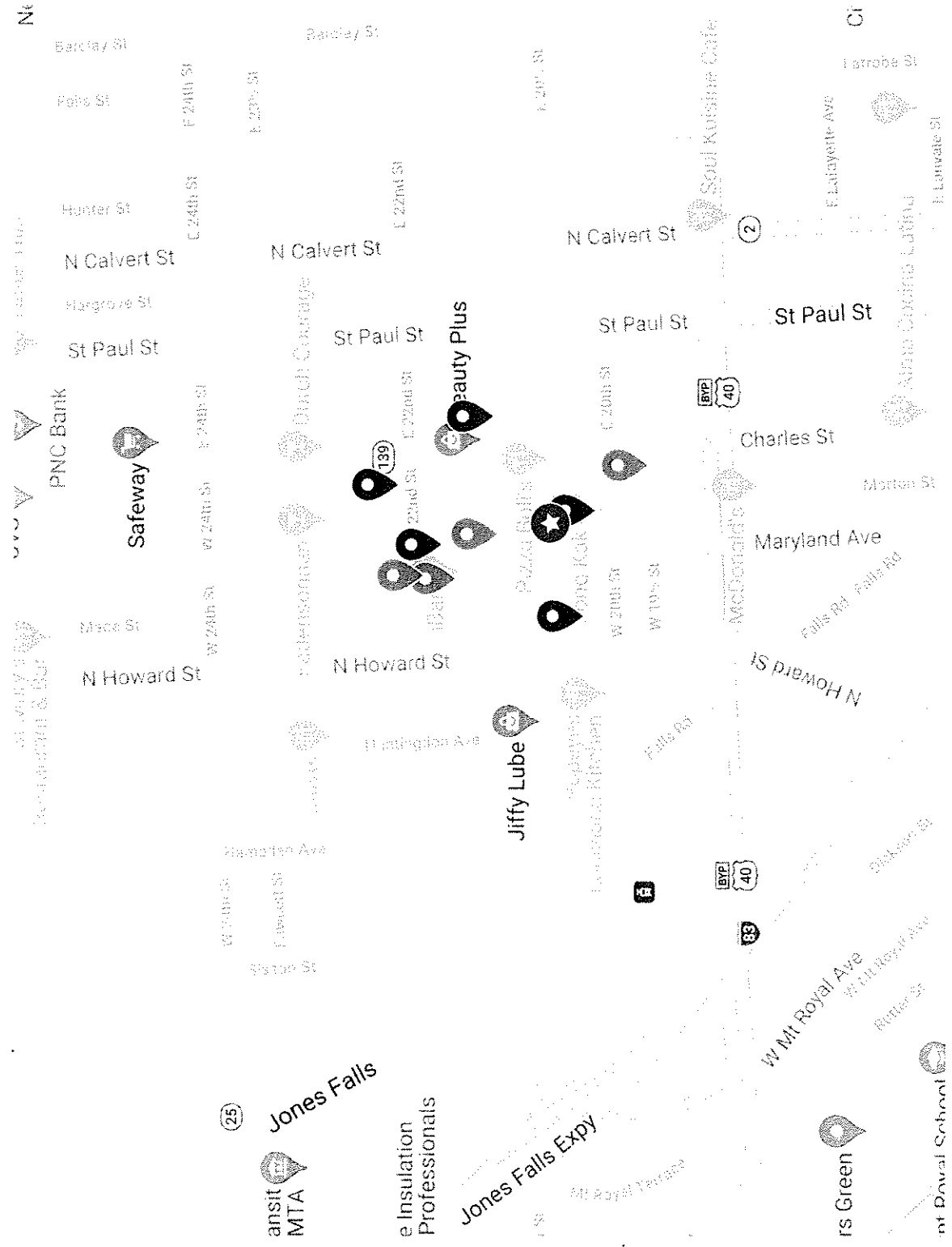



# Board of Liquor License Commissioners

For Baltimore City  
1 North Charles Street, 15th Floor  
Baltimore, Maryland, 21201

## INSPECTORS REPORT - TRANSFERS/NEW APPLICATIONS

Licensee Information (Trade Name):	Pending
Corporation Name:	Door 61 LLC
Location Address:	2021 Maryland Ave
License Type:	Class "B" Beer, Wine and Liquor <input type="checkbox"/>
Is the establishment open and operating in a safe and sanitary manner? (If not open, not in comments - CLOSED or NOT OPERATING)	No <input type="checkbox"/>
Is the location within 300 feet of Church and/or School?	No <input type="checkbox"/>
Date Posted?	8/25/2021 <input type="checkbox"/>
Estimated Date of Removal?	9/3/2021 <input type="checkbox"/>
Are there any other licensed establishments within a two block radius?	Yes <input type="checkbox"/>

**Other licensed locations - Describe/Note:**

Please see map for additional locations

**Comments and Follow-up Items(s) (please note any issues or concerns about the location):**

Filed application for new LB restaurant license with outdoor table service and off premises catering .

**Insert Photo of Sign and location:**

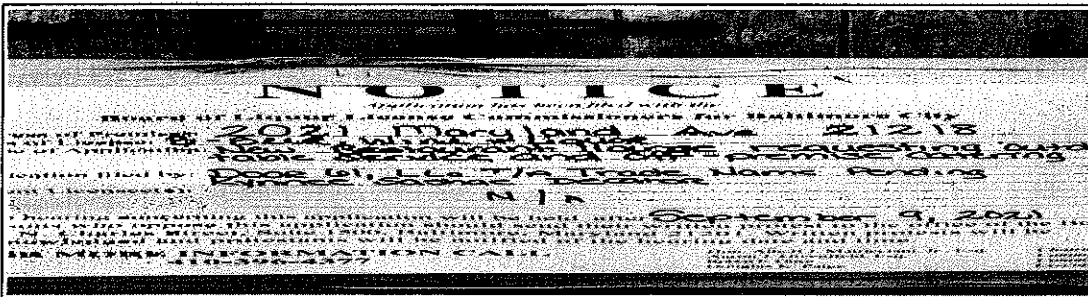

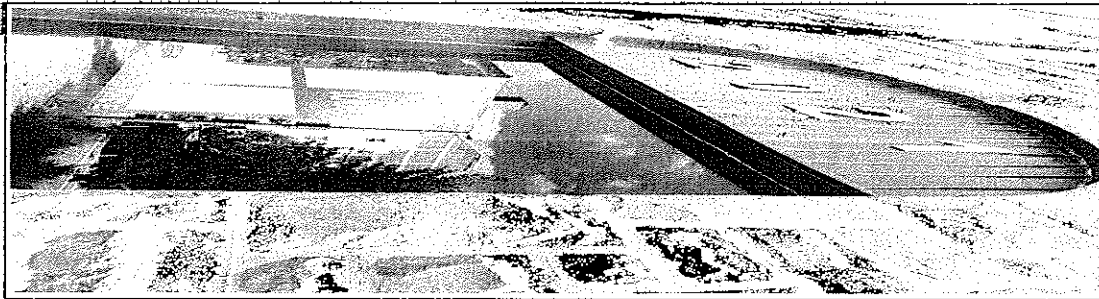

Attach Additional Photos

Inspector Name		Date and Time	
<input type="text" value="i:\0#w\baltimore\darryl.clark"/>		<input type="text" value="8/25/2021"/>	<input type="text" value="10:49:15 AM"/>
Name of Licensee (if present)			
<input type="text"/>			
Approve		Disapprove	

### Board of Liquor License Commissioners

For Baltimore City  
1 North Charles Street, 15th Floor  
Baltimore, Maryland, 21201

### POSTING SIGNS REPORT

Applicant(s) Name:

Address of Premises:

Inspector:

Date Posted:

Time Posted:

Date Rechecked:

Time Rechecked:

Manager or Owner when sign posted:

*Summary on location of sign posted:*

Sign posted on the front door

*Summary on location of sign rechecked:*

Sign still posted on the front door

*Insert Photo of Sign and location:*

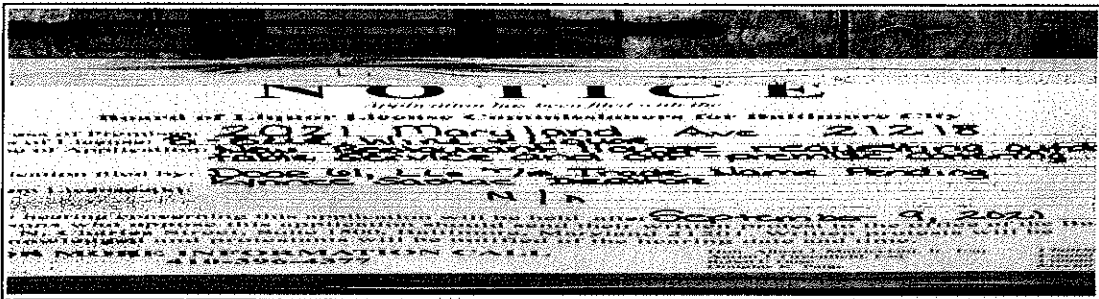

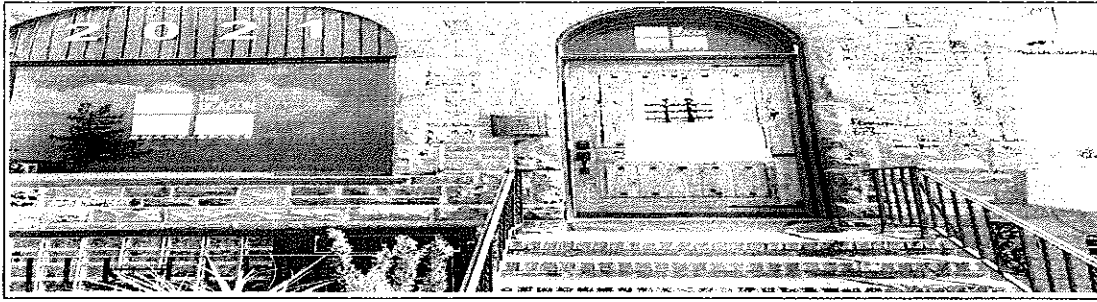

└ Attach Additional Photos

Approve

Disapprove

# NOTICE

*Application has been filed with the*

## Board of Liquor License Commissioners for Baltimore City

Address of Premises: 2021 Maryland Ave 21218  
Type of License: B-BLR, Wine & Liquor  
Purpose of Application: New Restaurant license requesting outdoor table service and off-premise catering  
Applicant: Door 61, LLC T/A Trade Name Pending  
Kymee Saahae Decator  
Applicant Licensee(s): N/A

A hearing concerning this application will be held after September 9, 2021. Persons who oppose this application should send their written protest to the office of the Board of Liquor License Commissioners, 100 N. Charles Street, Suite 1500, Baltimore, Maryland 21201. Written protests will be acknowledged and protestants will be notified of the hearing date and time.

**FOR MORE INFORMATION CALL**  
**410-396-4377**

Hon. Albert J. Matricciani, Jr., Esq. *Chairman*  
Aaron J. Greenfield, Esq. *Commissioner*  
Robert E. Guye *Commissioner*  
Douglas K. Paige *Executive Director*

Department Of Housing And Community Development  
Division Of Construction And Building Inspection

Online Use & Occupancy Permit  
Application

Property Address: 2021 MARYLAND AVE Block/Lot: 3603/011

Permit No: **USE2021-51806**

Applicant:  
ABRAHAM HURDLE

1001-000000-2600-159400-400540 Filing Fee	50.00
1001-000000-1500-102800-400230 Tax	3.00
1001-000000-2600-158009-400480 Use&Occupancy	45.00
Total :	<b>98.00</b>

Owner/Lessee:  
Owner ELIJAH KELLEY  
  
Lessee DOOR 61 LLC NA

**Please pay the Use & Occupancy permit fee  
before scheduling inspections.**

---

**Property Use & Occupancy Information:**

Existing Use : (N/A) Vacant House/Building/Structure

Proposed Use : (Commercial) Restaurant

	Dwelling:	Roomming:	Efficiency:
Existing Count:	001	000	000
Proposed Count:	0	0	0

Description	Created	Completed	Assigned To
One Stop Permit Office Review	04/22/2021		SMIT
R79 - CHARLES NORTH REVIT AREA Application Received	04/22/2021	04/22/2021	KLAW
Zoning Sign-off	04/22/2021	04/22/2021	

District:503

MINOR PRIVILEGE:

THIS IS NOT A PERMIT. THIS DOCUMENT IS PROOF OF APPLICATION FOR A PERMIT. YOU MUST OBTAIN THE ACTUAL PERMIT OR CERTIFICATE OF OCCUPANCY BEFORE THE BELOW STATED WORK OR USE CAN BEGIN. FOR MORE INFORMATION CONTACT THE ONE STOP SHOP PERMIT CENTER AT 443-984-1809.

---

USE THE FIRST FLOOR AS A RESTAURANT WITH OUTDOOR SEATING.

**AFFIDAVIT BY: ABRAHAM L HURDLE**

THE OWNER OF THE DESCRIBED PROPERTY FOR THE PROJECT NAMED BELOW HEREBY APPROVED THIS PERMIT APPLICATION AND AGREES TO COMPLY WITH ALL ORDINANCES OF THE MAYOR AND CITY COUNCIL OF BALTIMORE AND TO DO NO WORK NOT SPECIFICALLY COVERED BY THIS APPLICATION. "I DECLARE UNDER PENALTIES OF PERJURY THAT THIS APPLICATION, INCLUDING ANY ACCOMPANYING PLANS, SPECIFICATIONS, ETC. HAS BEEN EXAMINED BY ME AND TO THE BEST OF MY KNOWLEDGE AND BELIEF IS A TRUE, CORRECT AND COMPLETE STATEMENT OF THE WORK TO BE COVERED BY THIS APPLICATION. I ALSO DECLARE THAT I AM THE OWNER OR HAVE SPECIFIC APPROVAL OF THE OWNER TO ACT AS AGENT FOR THIS APPLICATION .

Project Name: 2021 MARYLAND V2

Owner First Name: ELIJAH

Role: Agent

Owner Last Name Or Company Name: KELLEY

Applicant: HURDLE, ABRAHAM

Phone:

Project Note:

Address1:

Address2:

City:

State:

Zip:

)

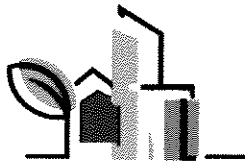

**BALTIMORE CITY  
DEPARTMENT OF HOUSING &  
COMMUNITY DEVELOPMENT**



**Search Results**

If you suspect that work is being performed without a permit or that the work is more than the scope of work indicates, please fill out a report at [311 Online](#).

Record Count : 12

(To organize your search click on the appropriate heading.)

Permit Number	Plan Number	Description	Address	District	Issued Date	Expiration Date	Neighborhood
USE2021-53680	-	USE 1ST FLOOR AND BASEMENT FOR RESTAURANT, WITH OUTDOOR SEATING	2021 MARYLAND AVE 1ST AND B	503			CHARLES NORTH
USE2021-53097	-	USE 1ST FLOOR AND BASEMENT FOR RESTAURANT, WITH OUTDOOR SEATING	2021 MARYLAND AVE 1ST AND B	503			CHARLES NORTH
COM2021-58725	-	Extend Original Permit (original permit:COM2020-79388: Extend Original Permit (original permit:COM2020-57425:INSTALL (2) 200 AMPS ELECTRIC SERVICE (>600 V), (50) # BRANCH CIRCUITS/FEEDERS , (32) # PLUMBING FIXTURES AS PER CODE ) Original Permit Description: (COM2020-57425) INSTALL (2) 200 AMPS ELECTRIC SERVICE (>600 V), (50) # BRANCH CIRCUITS/FEEDERS , (32) # PLUMBING FIXTURES AS PER CODE ) Original Permit Description: (COM2020-79388) Extend Original Permit (original permit:COM2020-57425:INSTALL (2) 200 AMPS ELECTRIC SERVICE (>600 V), (50) # BRANCH CIRCUITS/FEEDERS , (32) # PLUMBING FIXTURES AS PER CODE ) Original Permit Description: (COM2020-57425) INSTALL (2) 200 AMPS ELECTRIC SERVICE (>600 V), (50) # BRANCH CIRCUITS/FEEDERS , (32) # PLUMBING FIXTURES AS PER CODE.	2021 MARYLAND AVE	503	03/24/2021	09/24/2021	CHARLES NORTH
COM2021-56434	-	Extend Original Permit (original permit:COM2020-54930:SCOPE OF WORK: INTERIOR ALTERATIONS TO INCLUDE: FRAMING USING 2X4 TO CREATE NEW PARTITION WALLS ON THE FIRST AND SECOND FLOORS, INSTALL NEW DRYWALL, INSTALL NEW TRIM, INSTALL NEW INTERIOR DOORS, INSTALL NEW FLOORING, EXTERIOR	2021 MARYLAND AVE	503	03/03/2021	09/03/2021	CHARLES NORTH