

September 13, 2018

**Applicant(s):** Mandy Leeuwen  
Lighthouse Point Licensee, LLC, T/a Button  
2701 Boston Street 21224

**Class:** "BD7" Beer, Wine & Liquor License

Application to transfer ownership with continuation of outdoor table service, requesting off-premise catering and delivery of alcoholic beverages.

(a) **Applicant(s) Information:** (1) Mandy Leeuwen was born in Baltimore in May of 1980. She lives in Baltimore, MD.

(b) **Ownership Breakdown:** (1) Mandy Leeuwen (0%); and (2) J. Scott Plank (100%).

(c) **Purchase Price of Business:** The purchase price of the business was \$8,500,000 paid in full.

(d) **Qualified Voters:** Todd Sullivan, Keith Zickar, Jr., and Evalyn Tyson are qualified Baltimore City voters.

(e) **Zoning:** Applicant has applied for a USE permit, for the use of the property as a restaurant with outdoor table service, off-premise catering and delivery of alcoholic beverages.

(f) **Corporate Standing:** Lighthouse Point Licensee, LLC is a MD LLC and as of 8/29/2018 is active and in good standing.

(g) **Posting Report:** The location was posted on 8/8/2018, and checked on 8/17/2018. This meets the 10-day rule. There are 7 licensed liquor establishments in the 4x4 area: "B" BWL-3; and "BD7" BWL- 4.

(h) **Timeline:** Last inspection by BLLC was performed on 8/9/2018. At that time, the establishment was open and operating.

(i) **Letters of Support/Opposition:** At this time the Board has no letter(s) of opposition or support.

In considering this request, under the provisions of Alcohol Beverages Article 4-210(A) the Board must consider the following factors: 1. The public need and desire for the license; 2. The number and location of existing license holders; 3. The potential effect on existing license holders of the license for which application is made; 4. The potential commonality or uniqueness of the services and products to be offered by the business of the applicant; 5. The impact of the license for which application is made on the health, safety, and welfare of the community, including issues relating to crime, traffic conditions, parking, or convenience; and 6. Any other factor that the local licensing Board considers necessary.

**Board's Decision:**

# 2018 Application for Alcoholic Beverages License Board of Liquor License Commissioners for Baltimore City

NEW/TRANSFER/EXPANSION/AMENDMENT(S) APPLICATION FEE - \$600.00

INDICATE TYPE OF LICENSE APPLICATION: TRANSFER  NEW  EXPANSION OF PREMISES  AMENDMENT(S)

EXPLANATION OF REQUEST: Transfer of Ownership Only CLASS TYPE: BD7

*Please select one option and fill out the requested information*

A) NEW LICENSE REQUEST: ADDRESS OF PROPOSED LOCATION: \_\_\_\_\_

B) TRANSFER OF OWNERSHIP ONLY: ADDRESS OF CURRENT LICENSE: 2701 Boston Street, License #LBD7 074

C) TRANSFER OF OWNERSHIP AND LOCATION: CURRENT ADDRESS OF LICENSED LOCATION: \_\_\_\_\_

TRANSFER OF OWNERSHIP AND LOCATION: ADDRESS OF PROPOSED RELOCATION: \_\_\_\_\_

---

CORPORATE/LLC/LLP/PARTNERSHIP NAME: Lighthouse Point License, LLC TRADE NAME: Button

BUSINESS PHONE NUMBER: 443-478-1210 BUSINESS EMAIL ADDRESS: vickie@warhorsecities.com

ATTORNEY FOR THE APPLICANT: Joseph R. Woolman ADDRESS: 111 S. Calvert St., #2700, Balto. MD 21201 PHONE: 410-385-5328

Part of Premises Used (Note: Floors and Areas for Storage): Entire Premises Outdoor Table Service Provided?  Yes  No Delivery of alcohol?  Yes  No  
 Live Entertainment provided?  Yes  No What Kind (Ex. D.J. Band, Etc.)? \_\_\_\_\_ Off Premise Catering of Food and Alcohol?  Yes  No  
 Zoning Receipt or Current Certificate of Occupancy Permit attached to Application?  Yes  No Estimated Seating Capacity: \_\_\_\_\_

*Please note that as per Alc. Bev. Art. § 12-1407(A)(2), an application for the issuance or transfer, is not complete unless the applicant has obtained approval and/or verification from the Baltimore Municipal Zoning Administration (BMZA)*

### 1. Applicant A

Mandy Leeuwen \_\_\_\_\_ (Telephone no.) \_\_\_\_\_ E-mail (Required) \_\_\_\_\_  
 (Full name) \_\_\_\_\_  
 6622 Hartwait Street \_\_\_\_\_ Baito. MD 21224 8 years \_\_\_\_\_  
 (Residence) Street \_\_\_\_\_ City \_\_\_\_\_ State \_\_\_\_\_ Zip Code \_\_\_\_\_ (period of residency in Baltimore City)  
 05/1980 \_\_\_\_\_ Female \_\_\_\_\_ Baltimore \_\_\_\_\_  
 (Month/Year of Birth) \_\_\_\_\_ (Sex: Male or Female) \_\_\_\_\_ (Place of Birth)  
 Check:  Yes  No Have you been a resident and taxpayer of the City of Baltimore for 2 years preceding this application?  
 Yes  No Are you a registered voter in the City of Baltimore?

### 2. Applicant B

\_\_\_\_\_  
 (Full name) \_\_\_\_\_ (Telephone no.) \_\_\_\_\_ E-mail (Required) \_\_\_\_\_  
 \_\_\_\_\_  
 (Residence) Street \_\_\_\_\_ City \_\_\_\_\_ State \_\_\_\_\_ Zip Code \_\_\_\_\_ (period of residency in Baltimore City)  
 \_\_\_\_\_  
 (Month/Year of Birth) \_\_\_\_\_ (Sex: Male or Female) \_\_\_\_\_ (Place of Birth)  
 Check:  Yes  No Have you been a resident and taxpayer of the City of Baltimore for 2 years preceding this application?  
 Yes  No Are you a registered voter in the City of Baltimore?

### 3. Applicant C

\_\_\_\_\_  
 (Full name) \_\_\_\_\_ (Telephone no.) \_\_\_\_\_ E-mail (Required) \_\_\_\_\_  
 \_\_\_\_\_  
 (Residence) Street \_\_\_\_\_ City \_\_\_\_\_ State \_\_\_\_\_ Zip Code \_\_\_\_\_ (period of residency in Baltimore City)  
 \_\_\_\_\_  
 (Month/Year of Birth) \_\_\_\_\_ (Sex: Male or Female) \_\_\_\_\_ (Place of Birth)  
 Check:  Yes  No Have you been a resident and taxpayer of the City of Baltimore for 2 years preceding this application?  
 Yes  No Are you a registered voter in the City of Baltimore?

1. Has the applicant(s) been adjudged guilty of a felony in the State of Maryland or any other?  Yes  No - If yes, indicate applicant and explain.  
Applicant A  B  C

2. Has the applicant(s) been adjudged guilty of violating the laws governing the sale of any alcoholic beverage or for gambling in any State, including Maryland?  Yes  No - If yes, mark applicant and provide explanation in adjacent space provided.

Applicant A  B  C

3. State whether the applicant(s) has ever been adjudged guilty of any offense against the laws of the State of Maryland, any other State within the United States, or against the United States (Federal Crime)?  Yes  No - If yes, mark applicant and explain.

Applicant A  B  C

4. Has the applicant(s) ever had a license for the sale of alcoholic beverages in the State of Maryland?  Yes  No If yes, mark applicant and explain (address of location, dates that the applicant was a licensee, and the trade name).

Applicant A  B  C

5. Has the applicant(s) ever had a liquor license suspended or revoked?  Yes  No If yes, mark applicant and explain.

Applicant A  B  C

6. Does the applicant(s) have a financial interest in any other alcoholic beverage business or business for which an alcoholic beverage license has been applied for, granted, and issued?  Yes  No If yes, mark applicant and explain (address of location and trade name).

Applicant A  B  C

7. Do the spouses or children of any of the applicant(s) have a financial interest in any other alcoholic beverages license or business in Baltimore City or any other jurisdiction in the State of Maryland?  Yes  No If yes, mark applicant and explain (address of location and trade name).

Applicant A  B  C

8. Are you financially interested in any other alcoholic beverages license applied, granted or issued?  Yes  No If yes, please explain.

Applicant A  B  C

9. Is the licensed premise currently open and operating?  Yes  No If no, then provide date of last day of operation of the establishment.

10. Do any of the applicant(s) - personally or through an entity - have any indebtedness or other financial obligations to any manufacturer, brewer, distiller, or wholesaler at the time of making this application?  Yes  No If yes, please explain. If yes, please provide information as to the applicant(s) indebted - personally or through an entity - the amount of the indebtedness, and the name of the manufacturer, brewer, distiller, or wholesaler?

Applicant A  B  C

II. Please list the following information for the Manager of the establishment to be licensed:

Name	Address	Phone	Email
Mandy Lee Wan	6622 Hartwait Street Balt., MD 21224	[REDACTED]	[REDACTED]

Applicants Applying as Business Entities - (Give names) and addresses - in Corporation list all officers (attach list if necessary) or in Limited Liability Company/Partnerships list all authorized persons. **Please note that all licensees MUST have a FINANCIAL INTEREST in the license applied for as per Alc. Bev. Art. 5-4-109 (a)(11). If necessary, please attach a list of the names and address of all outstanding stock holders who at the time of application own any stock of the corporation and the articles of incorporation, partnership agreement or articles of organization.**

1 NAME	J. Scott Plank	ADDRESS	1200 Steua St Unit 2312	TITLE	Sole Member	% OF STOCK HELD	100
2 NAME		ADDRESS	Balt., MD 21230	TITLE		% OF STOCK HELD	
3 NAME		ADDRESS		TITLE		% OF STOCK HELD	
4 NAME		ADDRESS		TITLE		% OF STOCK HELD	

*\*Extract from Law: If any affidavit or oath required under the provisions of this Act shall contain any false statements, the offender shall be deemed guilty of perjury. And upon indictment and conviction thereof, shall be subject to penalties provided by Law for that crime.*

**CERTIFICATE OF APPLICANTS.** At least one applicant whose signature appears below certifies that he/she has been a resident and taxpayer of Baltimore City, Maryland for at least two years preceding the filing of this application. Each of said applicants hereby certifies further that if the license applied for is granted, he/she will conform to all State and County laws and regulations relating to the sale of alcoholic beverages, as well as to the rules and regulations of the Board of License Commissioners for Baltimore City, and hereby grants permission to the State Comptroller, his duly authorized deputies, inspectors and clerks, The Board of License Commissioners for Baltimore City, its duly authorized agents and employees, and any peace officer of Baltimore City or the State of Maryland to inspect and search at any and all hours, without warrant, the premises and any and all parts thereof upon and in which said business is to be conducted.

Mandy Lee Wan  
Signature of Applicant A

I hereby certify that on the 4<sup>th</sup> day of June, 2018 before me the subscriber a notary public of the State of Maryland and County of Harford personally appeared Mandy Lee Wan the applicant(s) named in this application and made oath in due form of law that the matter and facts contained in said application are true and correct. As witness my hand and notarial seal.

Signature Vickie L. Hilditch (Notary Seal) My Commission expires 8-22-19  
Printed Name Vickie L. Hilditch

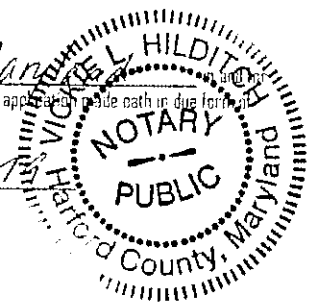

Signature of Applicant B

I hereby certify that on the \_\_\_\_\_ day of \_\_\_\_\_, 20\_\_\_\_ before me the subscriber a notary public of the State of \_\_\_\_\_ in and for \_\_\_\_\_ personally appeared \_\_\_\_\_ the applicant(s) named in this application made oath in due form of law that the matter and facts contained in said application are true and correct. As witness my hand and notarial seal.

Signature \_\_\_\_\_ (Notary Seal) My Commission expires \_\_\_\_\_  
Printed Name \_\_\_\_\_

Signature of Applicant C

I hereby certify that on the \_\_\_\_\_ day of \_\_\_\_\_, 20\_\_\_\_ before me the subscriber a notary public of the State of \_\_\_\_\_ in and for \_\_\_\_\_ personally appeared \_\_\_\_\_ the applicant(s) named in this application made oath in due form of law that the matter and facts contained in said application are true and correct. As witness my hand and notarial seal.

Signature \_\_\_\_\_ (Notary Seal) My Commission expires \_\_\_\_\_  
Printed Name \_\_\_\_\_

Name and Address of the owners of the premise/landlord: 2760 Lighthouse Hospitality, LLC 900 E. Fort Avenue Ste. 900 Phone Number: [REDACTED]

STATEMENT OF OWNER OF PREMISES REQUIRED IN CONNECTION WITH ALCOHOLIC BEVERAGES LAW OF MARYLAND  
 (I/WE) J. Scott Plank HEREBY CERTIFY, That I/We, we are the owner(s) of the property located at 2723 Lighthouse Point East, Baltimore, City with a Zip Code of 21224, which is named in the present application made to Board of Liquor License Commissioners of Baltimore City under the Alcoholic Beverage Laws of Maryland and assent to the granting of the license applied for, and hereby authorize the State Comptroller, his duly authorized deputies, inspectors and clerks, the Board of Liquor License Commissioners of Baltimore City, its duly authorized agents and employees, and any peace officer of the City of Baltimore and State of Maryland, to inspect and search, without warrant, the premises upon which the business is to be conducted, and any and all parts of the building in which said business is to be conducted, at any and all hours.

[Signature]  
 Signature of Landlord

I hereby certify that on the 4th day of June, 2018, before me, the subscriber, a notary public of the State of Maryland, in and for County of Harford, personally appeared J. Scott Plank landlord/property owner named in this application made oath in due form of law that the matter and facts contained in said application are true and correct.

As witness, my hand and notarial seal.  
 Notary Signature: Vickie J. Hilditch

(Notary Seal) My Commission expires 8-22-19

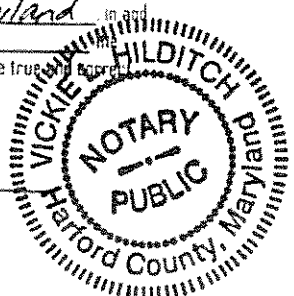

Notary Printed Name \_\_\_\_\_

**The following certificates must be signed by at least 3 persons.**

We, the undersigned citizens, real estate owners and registered voters in the City of Baltimore in which the business covered by the present application is to be conducted, certify that the qualifying applicant(s) is/are personally known to us and has been a resident or a taxpayer of Baltimore City and a resident of the State of Maryland for 2 years preceding this application.

Names	Address	Signature	DOB (Month/Year)	Length of time Acquainted with the Applicant(s)
Todd Sullivan	306 Northway Balto., MD 21218	[Signature]	10/03	3 years
Jessica F. Lisse	2706 Marbovere Ave Balto. MD 21230	[Signature]	07/81	10 years
Keith James Zickar, Jr.	3730 Claremont St. Balto, MD 21224	[Signature]	09/84	4 years
KEVALYN TYSON	21 West 27 <sup>th</sup> St Balto, MD 21218	[Signature]	04/60	5 years

Board of Liquor License Commissioners for the City of Baltimore.  
 231 East Baltimore Street, 6<sup>th</sup> Floor, Baltimore, Maryland 21202  
 Phone: 410-396-4377 Fax: 410-396-4382

Please note that this is a public document and upon request will be provided to the general members of the public.

RECEIVED

Name and Address of the owners of the premise/landlord: 2760 Lighthouse Hospitality LLC 900 E. Fort Avenue Ste 900 Phone Number: [REDACTED]

**STATEMENT OF OWNER OF PREMISES REQUIRED IN CONNECTION WITH ALCOHOLIC BEVERAGES LAW OF MARYLAND**

(I/WE) J. Scott Plank HEREBY CERTIFY That (I/am, we are) the owner(s) of the property located at 2723 Lighthouse Point East, Baltimore, City with a Zip Code of 21224 which is named in the present application made to Board of Liquor License Commissioners of Baltimore City under the Alcoholic Beverage Laws of Maryland and assent to the granting of the license applied for, and hereby authorize the State Comptroller, his duly authorized deputies, inspectors and clerks, the Board of Liquor License Commissioners of Baltimore City, its duly authorized agents and employees, and any peace officer of the City of Baltimore and State of Maryland, to inspect and search, without warrant, the premises upon which the business is to be conducted, and any and all parts of the building in which said business is to be conducted, at any and all hours.

[Signature]  
Signature of Landlord

I hereby certify that on the 4th day of June, 2018, before me, the subscriber, a notary public of the State of Maryland in and for County of Harford, personally appeared J. Scott Plank landlord/property owner named in this application made oath in due form of law that the matter and facts contained in said application are true and correct.

As witness, my hand and notarial seal.  
Notary Signature: Vickie J. Hilditch  
Notary Printed Name: \_\_\_\_\_

(Notary Seal) My Commission expires 8-22-19

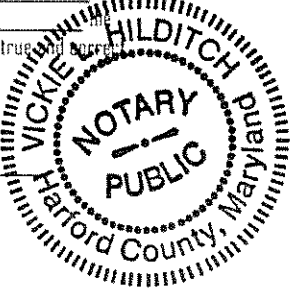

**The following certificates must be signed by at least 3 persons.**

We, the undersigned citizens, real estate owners and registered voters in the City of Baltimore in which the business covered by the present application is to be conducted, certify that the qualifying applicant(s) is/are personally known to us and has been a resident or a taxpayer of Baltimore City and a resident of the State of Maryland for 2 years preceding this application.

Names	Address	Signature	DOB (Month/Year)	Length of time Acquainted with the Applicant(s)
Todd Sullivan	300 Northway Balto., MD 21218	<u>[Signature]</u>	10/03	3 years
Jessica F. Reese	2705 Marbourne Ave. Balto., MD 21230	<u>[Signature]</u>	07/81	10 years
Keith James Zickar, Jr.	3730 Claremont St. Balto., MD 21224	<u>[Signature]</u>	09/84	4 years

Board of Liquor License Commissioners for the City of Baltimore  
231 East Baltimore Street, 6<sup>th</sup> Floor, Baltimore, Maryland 21202  
Phone: 410-396-4377 Fax: 410-396-4382

Please note that this is a public document and upon request will be provided to the general members of the public.

2018 JUN 29 PM 4:46

Revised December 2017 - Effective May 1, 2018

RECEIVED

**\*Please present/draw a Floor Plan/Rendering of the Licensed Premises here. If you have a professionally drafted rendering, please attach it to the application.\***

*See Attached*

# Swim Club & Button

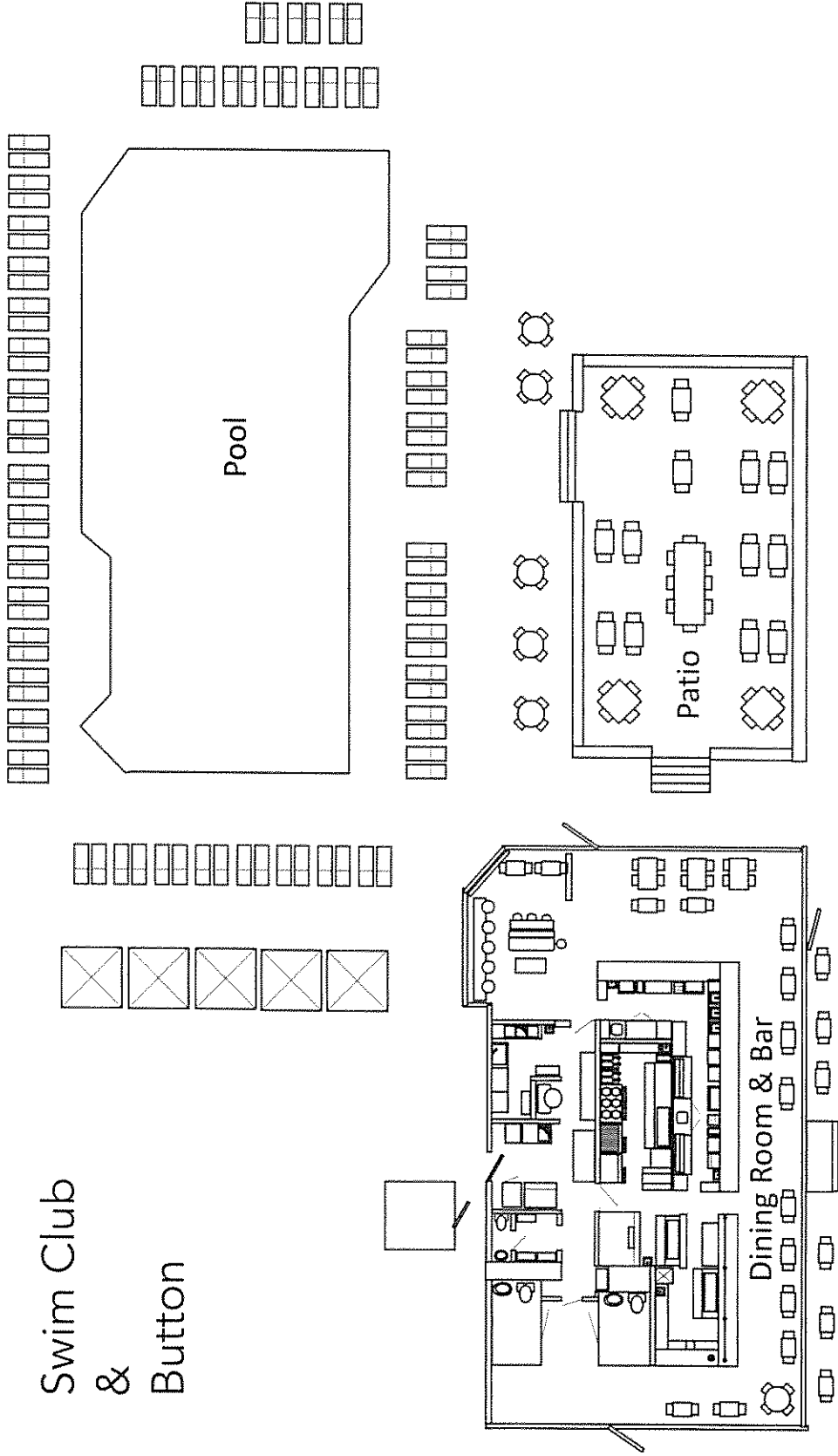



button  
Dining Room Floor Plan

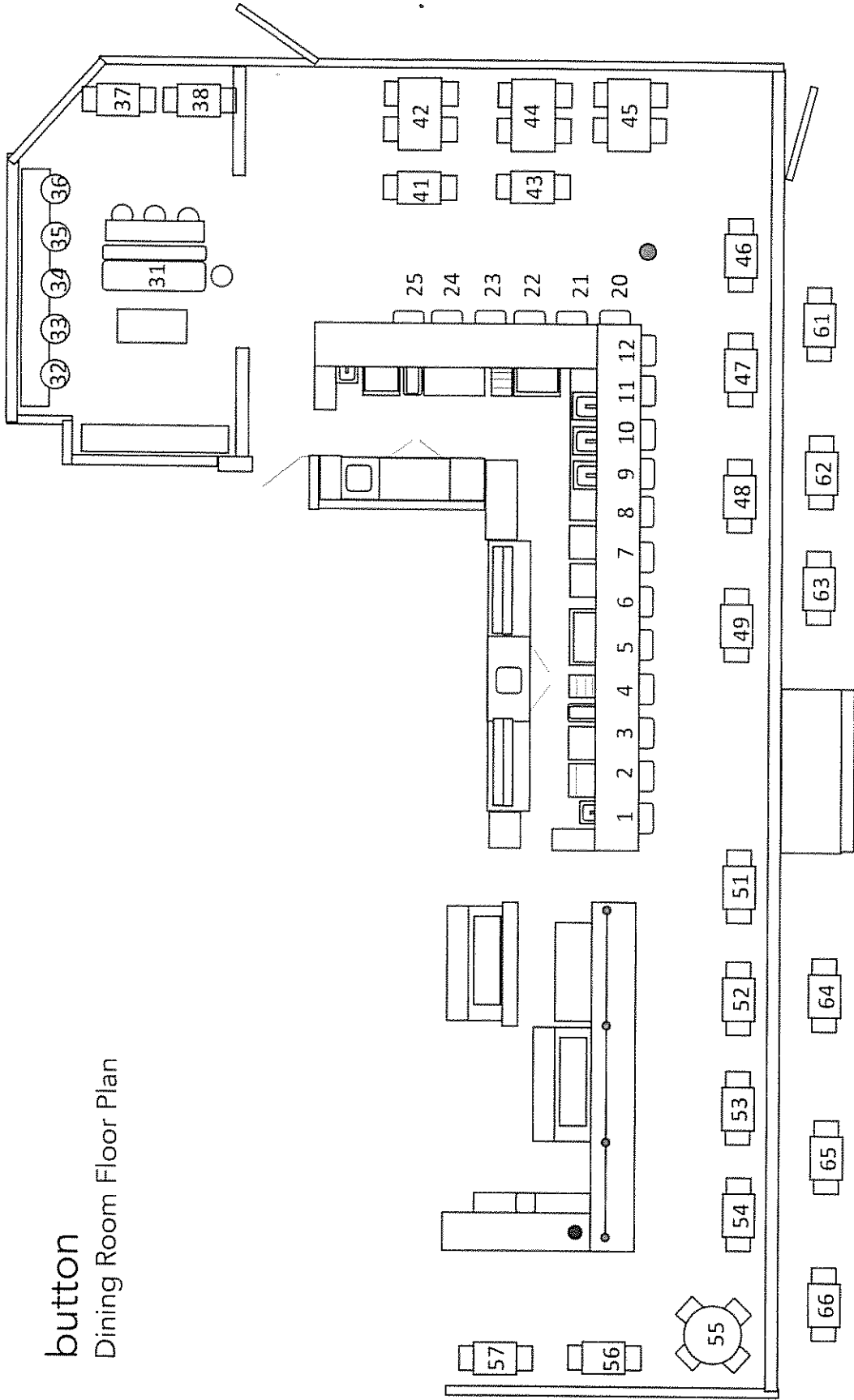

button  
Patio Floor Plan

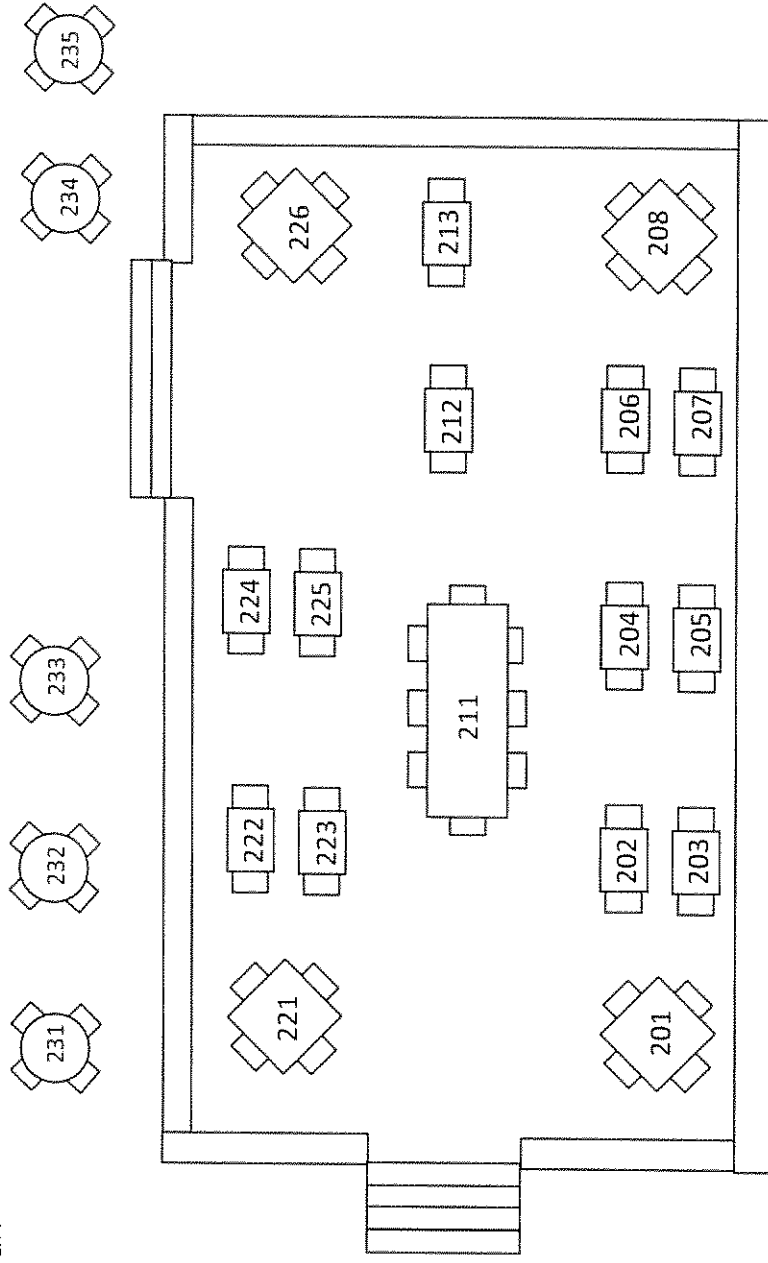

# swim club

## Pool Deck Seating Plan

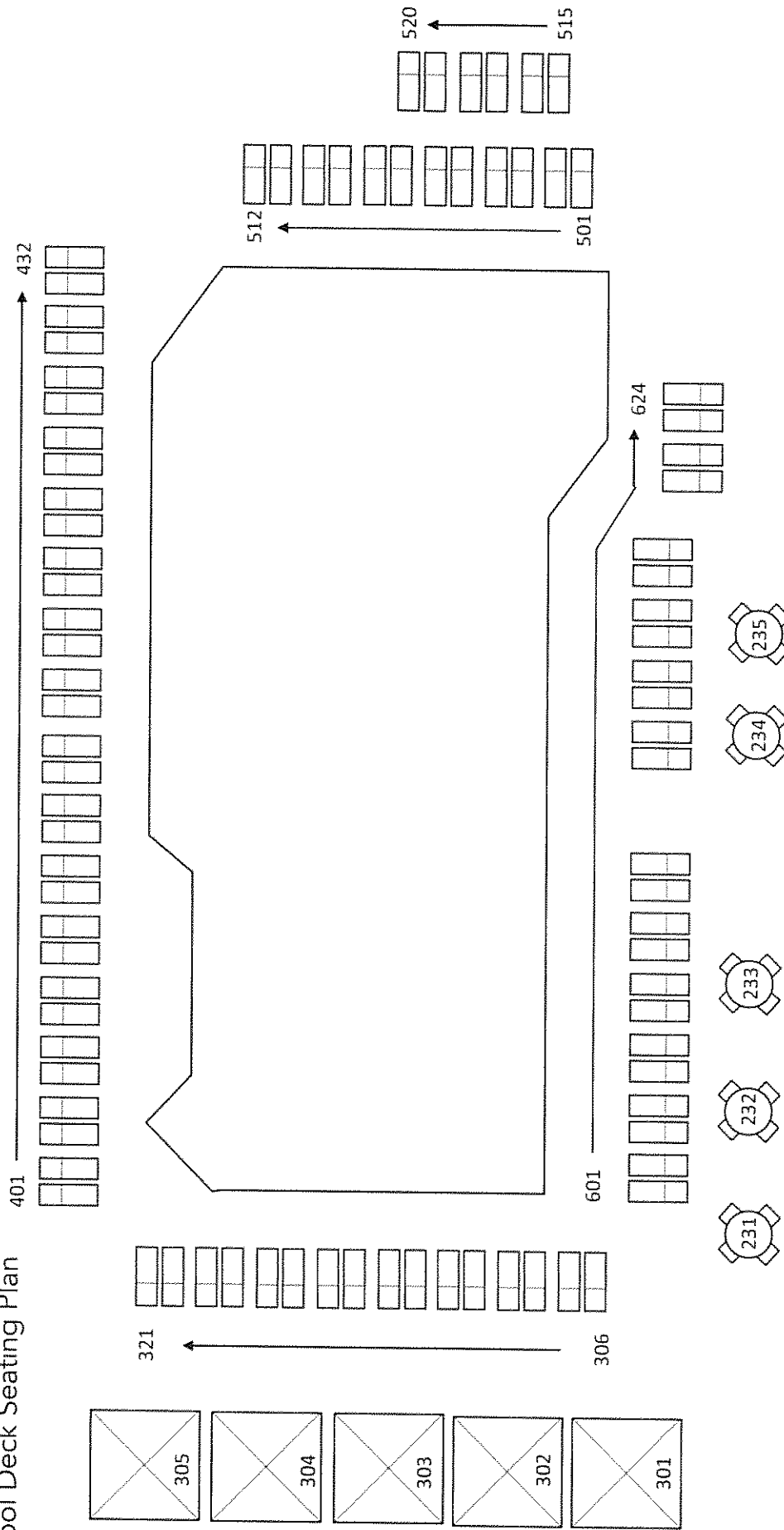



# Liquor Board System

Version 1.0

Annual-Renewal ▼ | License-Transfer ▼ | One-Day ▼ | Add New License ▼ | Query ▼ | Help ▼

## License Detail

### License Info

License Num: **LBD7 399**      Cert Num: **1152**      Fee: **\$1,320.00**      Status: **Renewed**  
 License Date: 5/1/2018      License Year: 2018  
 CR Number: 11786953  
 Payment Date: 04-30-18

2017 - 2018 TPP Paid   
 2018 Trader's License

Transfer to Another License

## Add Adult Entertainment License

### Location

Corp Name: **BALTIMORE MARINE CENTER, LLC**  
 Trade Name: **BALTIMORE MARINE CENTER**  
 Zone Code: 13  
 Phone: 410-675-8888

Block Num: 2701      Street: BOSTON STREET  
 City: BALTIMORE      State: MD      Zip: 21224

CR Number: 11786953

Portion of Business Used:  
 FIRST AND SECOND FLOORS FOR BUSINESS, POOL, KIOSK, SHIP STORE, FUEL DOCK FOR BUSINESS  
 Restriction:

### License Owners

First Name	Last Name	Street	City	State	Zip	Action	Change Owner
DAN	NAOR	26 WHITFIELD ROAD	BALTIMORE	MD	21210	<input type="button" value="Edit"/>	<input type="button" value="Remove Owner"/>

### Comments

Date	Comment	Action

08/08/2016	Licensee invoice # 103255, Check # 11333..../sb	Delete
01/19/2010	01/19/10 \$100(180 DAY CONF) PAID IN FULL #70666	Delete
06/10/2009	06/09/09 \$100 CONF.FEE PAID IN FULL #69345	Delete
05/15/2009	05/09 Transfer of Ownership, Selvin Passen, Dan Naor, Baltimore Marine Center, LLC	Delete
03/01/2004	2/15/96 Public hearing re: Application to transfer ownership and location of the existing Class BD7 license presently in the name of Frank Jugo, Personal Representative, at 1818-20 Gough Street to the applicants at the new location 2701 Boston Street APPROVED	Delete

Print History (Print Card)

License num: LBD7 399      Address: 2701 BOSTON STREET  
 Trade Name: BALTIMORE MARINE CENTER

Comment:

Add Comment

Hold Info



## LIGHTHOUSE POINT LICENSE, LLC: W18836221

General Information

Filing History

Annual Report/Personal Property

### General Information

**Department ID Number:**

W18836221

**Business Name:**

LIGHTHOUSE POINT LICENSE,  
LLC

**Principal Office:**

STE.900  
900 E. FORT AVE.  
BALTIMORE MD 21230

**Resident Agent:**

VICKIE HILDITCH  
STE.900  
900 E. FORT AVE.  
BALTIMORE MD 21230

**Status:**

ACTIVE

**Good Standing:**

THIS BUSINESS IS IN GOOD  
STANDING

» [Order Certificate of Status](#)

**Business Type:**

DOMESTIC LLC

**Business Code:**

20 ENTITIES OTHER THAN  
CORPORATIONS

**Date of Formation/ Registration:**

05/21/2018

**State of Formation:**

MD

**Stock Status:**

N/A

**Close Status:**

N/A

PROPOSED LOCATION: 2701 Boston St.

### MAP SUMMARY (RECAPITULATION)

TOTAL ESTABLISHMENTS IN MAP AREA 7

"A" BEER & WINE \_\_\_\_\_

"B" BEER & WINE \_\_\_\_\_

"C" BEER & WINE \_\_\_\_\_

"D" BEER & WINE \_\_\_\_\_

"A" BEER, WINE & LIQUOR \_\_\_\_\_

"A-2" BEER, WINE & LIQUOR \_\_\_\_\_

"B" BEER, WINE & LIQUOR 3

"C" BEER, WINE & LIQUOR \_\_\_\_\_

"D" BEER, WINE & LIQUOR \_\_\_\_\_

"BD7" BEER, WINE & LIQUOR 4

ARENA \_\_\_\_\_

HOTEL/MOTEL \_\_\_\_\_

RACING \_\_\_\_\_

PREPARED BY: \_\_\_\_\_ DATE: \_\_\_\_\_

# 2701 Boston St

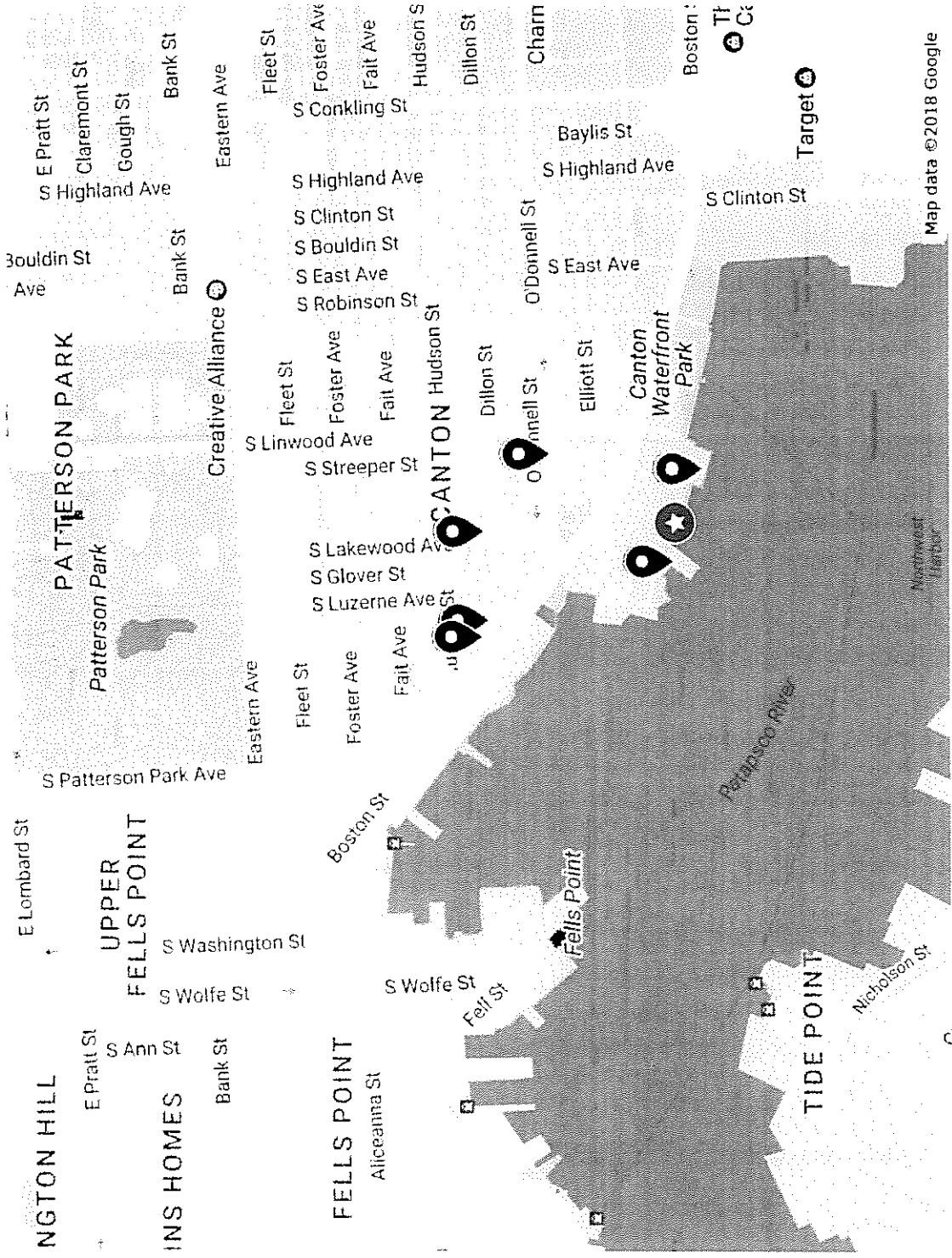

**Proposed Location**

2701 Boston St

**Licensed Establishments**

- Ro Brooks Restaurant LBD7
- Boathouse Canton LBD7
- Canton's Portside LBD7
- Mahaffey's Pub LB
- Outback Steakhouse LB
- Chesapeake Wine Co. LBD7
- Alma Cocina Latina LB



Board of Liquor License Commissioners

For Baltimore City  
1 North Charles Street, 15th Floor  
Baltimore, Maryland, 21201

**INSPECTORS REPORT - TRANSFERS/NEW APPLICATIONS**

Licensee Information (Trade Name):	Button
Corporation Name:	Lighthouse Point License, LLC
Location Address:	2701 Boston St
License Type:	Class "BD7" Beer, Wine and Liquor
Is the establishment open and operating in a safe and sanitary manner? (If not open, not in comments - CLOSED or NOT OPERATING)	Yes
Is the location within 300 feet of Church and/or School?	No
Date Posted?	8/8/2018
Date Removed?	
Are there any other licensed establishments within a two block radius?	Yes

Other licensed locations - Describe/Note:

See attached map

Comments and Follow-up Items(s) (please note any issues or concerns about the location):

Application filed for transfer of ownership and request to add outdoors table service and delivery of alcoholic beverages.

Insert Photo of Sign and location:

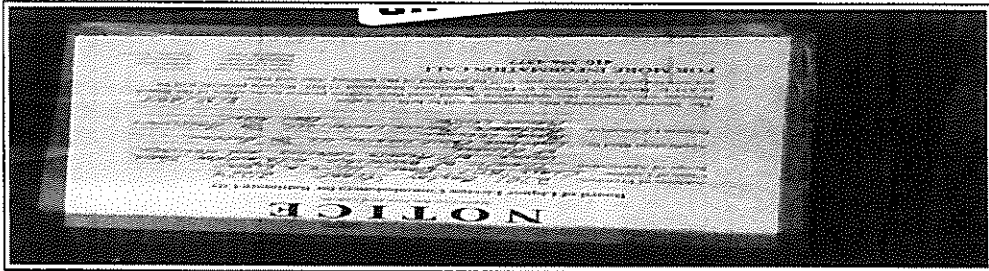

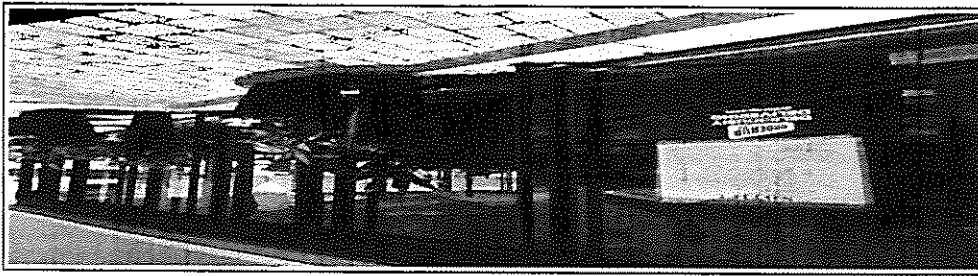

Inspector Name	Date and Time	
<input type="text" value="i:\0#.w\baltimore\andy.perez"/>	<input type="text" value="8/24/2018"/>	<input type="text" value="12:38:40 PM"/>
Name of Licensee (if present)		
<input type="text"/>		

# Board of Liquor License Commissioners

For Baltimore City  
1 North Charles Street, 15th Floor  
Baltimore, Maryland, 21201

## POSTING SIGNS REPORT

Applicant(s) Name:	Mandy Leeuwen
Address of Premises:	2701 Boston St.
Inspector:	i:0# w baltimore\andy.perez
Date Posted:	8/8/2018
Time Posted:	3:00 PM
Date Rechecked:	8/17/2018
Time Rechecked:	6:00 PM
Manager or Owner when sign posted:	

Summary on location of sign posted:

Sign posted on

Summary on location of sign rechecked:

Sign remained as posted for the required 10 days period.

Insert Photo of Sign and location:



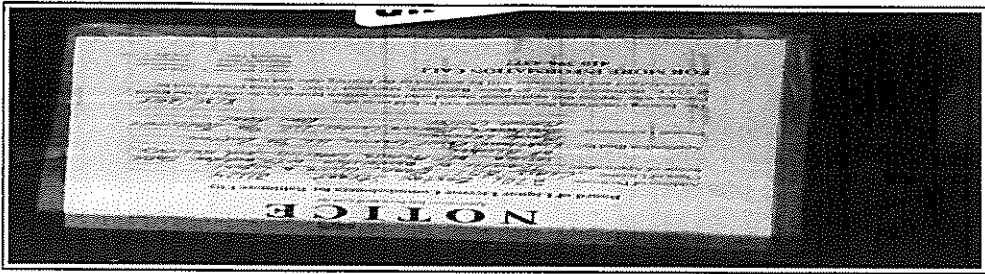

# BLLC Routine Inspection

## Licensee Information

Address: 2701 BOSTON STREET 21224

Trade Name: BALTIMORE MARINE CENTER

Corporation Name: BALTIMORE MARINE CENTER, LLC

Type of License: Class "BD7" Beer, Wine and Liquor

Date/Time of Inspection: 8/9/2018 10:17:48 AM

Manager/Licensee: Rachel Berkowitz

## Open/Closed Status

Open/Closed: Open

Closed Date:

## External Appearance

Clean and Free of Debris: Satisfactory

## Internal Appearance

Location of Bar: Center

Shape of Bar: squared

Condition of Bar Area/Floors: Satisfactory

Hot Water: Yes

Disinfectant Solution: Yes

Three Compartment/Washer: Yes

## Package Goods/BD7 Checklist

Bulletproof Partitioning: No

Separate Pkg. Goods Dept.: No

Separate Pkg. Goods Store: No

Bar/Tavern Open and Operating: Yes

Selling Household/Grocery: No

Dining Area

Capacity:

Location of Dining Area:

Condition of Dining Area/Floors: Satisfactory

Sanitation: Satisfactory

Menu: Yes

Business Records

Traders License: No

Alcohol Awareness Certification Date Issued: 12/1/2017

Employee Records: Yes

Alcohol Beverage Information Invoice Numbers and Date:

Kitchen

Inspector Comments:

Restroom

Inspector Comments:

Public Safety

Exits Marked, Unobstructed: Yes

Fire Capacity:

Outdoor Seating Capacity:

Adult Entertainment - If Applicable

License is Valid N/A

Dancers Present 18 and older: N/A

Cleanliness of Dressing Room: N/A

*Ancillary Services*

Live Entertainment (Describe):

no

Outdoor Table Service Yes

*Violations*

Violation Issued: No

Violations Noted:

*Wrap-Up*

Instructions Given to Licensee:

Inspector's Comments:

Inspected 8/8/18

Photo Taken.

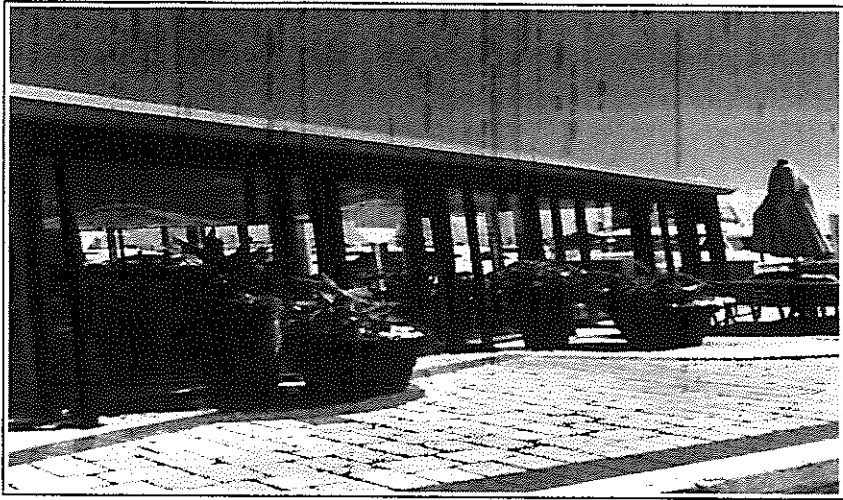

Owner Email:

Submitted by Inspector





Department Of Housing And Community Development  
Division Of Construction And Building Inspection

No: USE2009-02966

THIS WRITTEN INSTRUMENT, WHEN PROPERLY VALIDATED, CONSTITUTES AUTHORITY FOR DOING OR RECEIVING THE THINGS INDICATED BY THE FEES OR CHARGES SHOWN IN THE APPROPRIATE SPACES BELOW. ANY AND ALL THINGS TO BE DONE OR RECEIVED UNDER THIS WRITTEN INSTRUMENT SHALL BE DONE OR RECEIVED IN STRICT COMPLIANCE WITH THE APPLICATION HERETOFORE FILED IN THIS DEPARTMENT FOR THE AUTHORITY CONTAINED HEREIN, INCLUDING ANY AND ALL APPROVED DRAWINGS AND OTHER DATA OR INFORMATION ATTACHED THERETO, AND SUBJECT TO ANY AND ALL LAWS, ORDINANCES, RULES AND REGULATIONS IN EFFECT BY THE CITY OF BALTIMORE AND THE STATE OF MARYLAND. WARNING: IT IS UNLAWFUL TO WORK BETWEEN THE HOURS OF 7:00 PM AND 7:00 AM WITHIN 300 FEET OF A DWELLING.

WARNING: IT IS UNLAWFUL TO CONCEAL ANY WORK UNTIL INSPECTED AND APPROVED BY THIS DEPARTMENT.

WARD	SEC. BLOCK	LOT	ISSUE DATE	DISTRICT	MINOR PRIVILEGE	PLANS NO.
01	09	1902E 003	12/16/09	202		

PROPERTY ADDRESS: 2701 BOSTON ST

OWNER: BALTIMORE MARINE CENTER 8888 ADDR: 2700 LIGHTHOUSE POINT UNIT 626 BALI  
 LESSEE: ADDR:  
 CONTR: ADDR:  
 LIC. NO. :  
 ELECTRICAL CONTRACTOR: LIC. NO. :  
 PLUMBING CONTRACTOR: LIC. NO. :  
 GAS FITTER: LIC. NO. :  
 HVAC & R CONTR.: LIC. NO. :

WORK COST	EXPIRATION DATE	LAND USE CODES 3-52
-----------	-----------------	---------------------

USE PORTION OF PREMISES AS A RESTAURANT NEW OPERATORS CHANGING FROM EAST MARINE CENTER LLC TO BALTIMORE MARINE CENTER LLC

A-001-139-260-00-000 PER. INSP.	A-001-131-260-09-000 MISC.	A-001-131-260-09-000 CH. USE	A-001-132-260-01-000 NEW BLDG.	A-001-132-260-02-000 ADDITIONS	
		45.00			
A-001-132-260-03-000 ALTERATIONS	A-001-132-260-04-000 REPAIRS	A-001-132-260-05-000 MISC. CONST.	A-001-133-260-00-000 ELECT.	A-001-134-260-01-000 HYDRONIC/STEAM HEAT	
A-001-134-260-02-000 DISTRIB/EXH	A-001-134-260-03-000 AIR COND.	A-001-14-260-04-000 DISP. TANKS	A-001-134-260-05-000 FIRE	A-001-134-260-06-000 FUEL-BURNING EQUIPMENT	
A-001-136-260-00-000 ELEVATOR	A-001-135-260-00-000 PLUMBING	A-001-132-260-07-000 S & E CONTROL	A-001-868-570-01-000 CHAP	A-001-051-150-00-000 TAX	3.00
A-001-132-260-06-000 RAZING	A-001-137-260-00-000 FILING FEE	A-001-132-260-02-000 LOW VOLTAGE/TELECOM	A-001-131-260-09-000 PENALTY	TOTAL FEES	98.00
	50.00				

INSPECTORS REPORT OF INSPECTION

DATE	TYPE OF INSPECTION & NOTE	INITIAL	DATE	TYPE OF INSPECTION & NOTE	INITIAL
COMPLETION DATE			INSPECTORS SIGNATURE		

September 13, 2018

**Applicant(s):** Breonna Cole and Aisha Pew  
Doubles Market & Grill, LLC, T/a Doubles Market & Grill  
2556 Madison Avenue 21217

**Class:** "D" Beer & Wine License

Application to transfer ownership requesting outdoor table service.

(a) **Applicant(s) Information:** (1) Breonna Cole was born in Washington, DC in February of 1978. She lives in Baltimore, MD; and (2) Aisha Pew was born in Brooklyn, NY in February of 1978. She lives in Baltimore, MD.

(b) **Ownership Breakdown:** (1) Breonna Cole (50%); and (2) Aisha Pew (50%).

(c) **Purchase Price of Business:** The purchase price of the business was \$50,000 paid in full.

(d) **Qualified Voters:** Linda Kennedy, Larry Coleman, and Morgan G. Hall, Jr. are qualified Baltimore City voters.

(e) **Zoning:** Applicants have applied for a USE permit, for the property as a store/restaurant with outdoor table service.

(f) **Corporate Standing:** Doubles Market & Grill, LLC is a MD LLC and as of 8/29/2018 is active and in good standing.

(g) **Posting Report:** The location was posted on 7/16/2018, and checked on 7/25/2018. This meets the 10-day rule. There are 0 licensed liquor establishments in the 4x4 area.

(h) **Timeline:** This request is a refile. Last application was approved on 6/29/2017; but applicants could not complete transfer in a timely manner due to delays. On 12/27/2017 staff received hardship letter request from the lawyer. According to request the establishment was closed as of 7/6/2017. The first 180 days of the hardship extension ran until 1/2/2018. On 1/25/2018 the Board granted a hardship extension. Applicants had until 7/1/2018 to file a transfer application. Transfer was filed on 6/29/2018. License is valid.

(i) **Letters of Support/Opposition:** At this time the Board has no letter(s) of opposition or support.

In considering this request, under the provisions of Alcohol Beverages Article 4-210(A) the Board must consider the following factors: 1. The public need and desire for the license; 2. The number and location of existing license holders; 3. The potential effect on existing license holders of the license for which application is made; 4. The potential commonality or uniqueness of the services and products to be offered by the business of the applicant; 5. The impact of the license for which application is made on the health, safety, and welfare of the community, including issues relating to crime, traffic conditions, parking, or convenience; and 6. Any other factor that the local licensing Board considers necessary.

**Board's Decision:**

# 2018 Application for Alcoholic Beverages License Board of Liquor License Commissioners for Baltimore City

*NEW/TRANSFER/EXPANSION/AMENDMENT(S) APPLICATION FEE - \$600.00*

INDICATE TYPE OF LICENSE APPLICATION: TRANSFER  NEW  EXPANSION OF PREMISES  AMENDMENT(S)

EXPLANATION OF REQUEST: Transfer of ownership CLASS TYPE: D

*Please select one option and fill out the requested information*

A) NEW LICENSE REQUEST: ADDRESS OF PROPOSED LOCATION: \_\_\_\_\_

B) TRANSFER OF OWNERSHIP ONLY: ADDRESS OF CURRENT LICENSE: 2556 Madison Avenue, Baltimore, MD 21217

C) TRANSFER OF OWNERSHIP AND LOCATION: CURRENT ADDRESS OF LICENSED LOCATION: \_\_\_\_\_

TRANSFER OF OWNERSHIP AND LOCATION: ADDRESS OF PROPOSED RELOCATION: \_\_\_\_\_

CORPORATE/LLC/LLP/PARTNERSHIP NAME: Doubles Market & Grill, LLC TRADE NAME: Doubles Market & Grill

BUSINESS PHONE NUMBER: 410-462-6013 BUSINESS EMAIL ADDRESS: \_\_\_\_\_

ATTORNEY FOR THE APPLICANT: Justin A. Williams, Esq. ADDRESS: 25 S. Charles Street, 21st Floor PHONE: 410-727-6600

Part of Premises Used (Note: Floors and Areas for Storage): Ground Floor Outdoor Table Service Provided?  Yes  No Delivery of alcohol?  Yes  No  
 Live Entertainment provided?  Yes  No What Kind (Ex. D.J. Band, Etc.): \_\_\_\_\_ Off Premise Catering of Food and Alcohol?  Yes  No  
 Zoning Receipt or Current Certificate of Occupancy Permit attached to Application?  Yes  No Estimated Seating Capacity: 22

*Please note that as per Alc. Bev. Art. § 12-1407(A)(2), an application for the issuance or transfer, is not complete unless the applicant has obtained approval and/or verification from the Baltimore Municipal Zoning Administration (BMZA)*

**1. Applicant A**

Breonna Cole \_\_\_\_\_  
 (Full name) (Telephone no.) E-mail (Required)  
 2545 Madison Avenue Baltimore MD 21217 2 years  
 (Residence) Street City State Zip Code (period of residency in Baltimore City)  
 02/1978 Female Washington, D.C.  
 (Month/Year of Birth) (Sex: Male or Female) (Place of Birth)  
 Check:  Yes  No Have you been a resident and taxpayer of the City of Baltimore for 2 years preceding this application?  
 Yes  No Are you a registered voter in the City of Baltimore?

**2. Applicant B**

Aisha Pew \_\_\_\_\_  
 (Full name) (Telephone no.) E-mail (Required)  
 2545 Madison Avenue Baltimore MD 21217 2 years  
 (Residence) Street City State Zip Code (period of residency in Baltimore City)  
 02/1978 Female Brooklyn, NY  
 (Month/Year of Birth) (Sex: Male or Female) (Place of Birth)  
 Check:  Yes  No Have you been a resident and taxpayer of the City of Baltimore for 2 years preceding this application?  
 Yes  No Are you a registered voter in the City of Baltimore?

**3. Applicant C**

\_\_\_\_\_  
 (Full name) (Telephone no.) E-mail (Required)  
 \_\_\_\_\_  
 (Residence) Street City State Zip Code (period of residency in Baltimore City)  
 \_\_\_\_\_  
 (Month/Year of Birth) (Sex: Male or Female) (Place of Birth)  
 Check:  Yes  No Have you been a resident and taxpayer of the City of Baltimore for 2 years preceding this application?  
 Yes  No Are you a registered voter in the City of Baltimore?

1. Has the applicant(s) been adjudged guilty of a felony in the State of Maryland or any other?  Yes  No - If yes, indicate applicant and explain.

Applicant A  B  C

2. Has the applicant(s) been adjudged guilty of violating the laws governing the sale of any alcoholic beverage or for gambling in any State, including Maryland?  Yes  No - If yes, mark applicant and provide explanation in adjacent space provided.

Applicant A  B  C

3. State whether the applicant(s) has ever been adjudged guilty of any offense against the laws of the State of Maryland, any other State within the United States, or against the United States (Federal Crime)?  Yes  No - If yes, mark applicant and explain.

Applicant A  B  C

4. Has the applicant(s) ever had a license for the sale of alcoholic beverages in the State of Maryland?  Yes  No If yes, mark applicant and explain (address of location, dates that the applicant was a licensee, and the trade name).

Applicant A  B  C

5. Has the applicant(s) ever had a liquor license suspended or revoked?  Yes  No If yes, mark applicant and explain.

Applicant A  B  C

6. Does the applicant(s) have a financial interest in any other alcoholic beverage business or business for which an alcoholic beverage license has been applied for, granted, and issued?  Yes  No If yes, mark applicant and explain (address of location and trade name).

Applicant A  B  C

7. Do the spouses or children of any of the applicant(s) have a financial interest in any other alcoholic beverages license or business in Baltimore City or any other jurisdiction in the State of Maryland?  Yes  No If yes, mark applicant and explain (address of location and trade name).

Applicant A  B  C

8. Are you financially interested in any other alcoholic beverages license applied, granted or issued?  Yes  No If yes, please explain.

Applicant A  B  C

9. Is the licensed premise currently open and operating?  Yes  No If no, then provide date of last day of operation of the establishment.

July 5, 2017

10. Do any of the applicant(s) - personally or through an entity - have any indebtedness or other financial obligations to any manufacturer, brewer, distiller, or wholesaler at the time of making this application?  Yes  No If yes, please explain. If yes, please provide information as to the applicant(s) indebted - personally or through an entity - the amount of the indebtedness, and the name of the manufacturer, brewer, distiller, or wholesaler?

Applicant A  B  C

II. Please list the following information for the Manager of the establishment to be licensed:

Name	Address	Phone	Email
TBD	TBD	TBD	TBD

Applicants Applying as Business Entities - (Give name(s) and addresses - in Corporation list all officers (attach list if necessary) or in Limited Liability Company/Partnerships list all authorized persons.) *Please note that all licensees MUST have a FINANCIAL INTEREST in the license applied for as per Alc. Bev. Art. § 4-109 (a)(II). If necessary, please attach a list of the names and address of all outstanding stock holders who at the time of application own any stock of the corporation and the articles of incorporation, partnership agreement or articles of organization.*

- 1) NAME Breonna Cole ADDRESS 2545 Madison Avenue TITLE Owner %OF STOCK HELD 50%  
 2) NAME Aisha Pew ADDRESS 2545 Madison Avenue TITLE Owner %OF STOCK HELD 50%  
 3) NAME: \_\_\_\_\_ ADDRESS: \_\_\_\_\_ TITLE: \_\_\_\_\_ %OF STOCK HELD: \_\_\_\_\_  
 4) NAME: \_\_\_\_\_ ADDRESS: \_\_\_\_\_ TITLE: \_\_\_\_\_ %OF STOCK HELD: \_\_\_\_\_

*\*Extract from Law: If any affidavit or oath required under the provisions of this Act shall contain any false statements, the offender shall be deemed guilty of perjury. And upon indictment and conviction thereof, shall be subject to penalties provided by Law for that crime.*

**CERTIFICATE OF APPLICANTS:** At least one applicant whose signature appears below certifies that he/she has been a resident and taxpayer of Baltimore City, Maryland for at least two years preceding the filing of this application. Each of said applicants hereby certifies further that if the license applied for is granted, he/she will conform to all State and County laws and regulations relating to the sale of alcoholic beverages, as well as to the rules and regulations of the Board of License Commissioners for Baltimore City, and hereby grants permission to the State Comptroller, his duly authorized deputies, inspectors and clerks, The Board of License Commissioners for Baltimore City, its duly authorized agents and employees, and any peace officer of Baltimore City or the State of Maryland to inspect and search at any and all hours, without warrant, the premises and any and all parts thereof upon and in which said business is to be conducted.

*Breonna Cole*  
 Signature of Applicant A

I hereby certify that on the 22<sup>nd</sup> day of June, 2018 before me, the subscriber, a notary public of the State of Maryland in and for Baltimore City, personally appeared Breonna Cole and Aisha Pew the applicant(s) named in this application made oath in due form of law that the matter and facts contained in said application are true and correct. As witness, my hand and notarial seal.

Signature *Margie Denise Vaughan*  
 Printed Name Margie Denise Vaughan

(Notary Seal) My Commission Expires August 23, 2020  
 MARGIE DENISE VAUGHAN  
 Notary Public-Maryland  
 Baltimore County  
 My Commission Expires  
 August 23, 2020

*Aisha Pew*  
 Signature of Applicant B

I hereby certify that on the 22<sup>nd</sup> day of June, 2018 before me, the subscriber, a notary public of the State of Maryland in and for Baltimore City, personally appeared Aisha Pew and Breonna Cole the applicant(s) named in this application made oath in due form of law that the matter and facts contained in said application are true and correct. As witness, my hand and notarial seal.

Signature *Margie Denise Vaughan*  
 Printed Name Margie Denise Vaughan

(Notary Seal) My Commission expires August 23, 2020

MARGIE DENISE VAUGHAN  
 Notary Public-Maryland  
 Baltimore County  
 My Commission Expires  
 August 23, 2020

\_\_\_\_\_  
 Signature of Applicant C

I hereby certify that on the \_\_\_\_\_ day of \_\_\_\_\_, 20\_\_\_\_ before me, the subscriber, a notary public of the State of \_\_\_\_\_ in and for \_\_\_\_\_ personally appeared \_\_\_\_\_ the applicant(s) named in this application made oath in due form of law that the matter and facts contained in said application are true and correct. As witness, my hand and notarial seal.

Signature \_\_\_\_\_  
 Printed Name \_\_\_\_\_

(Notary Seal) My Commission expires \_\_\_\_\_

Name and Address of the owners of the premise/landlord: Doubles Realty, LLC

Phone Number: [REDACTED]

STATEMENT OF OWNER OF PREMISES REQUIRED IN CONNECTION WITH ALCOHOLIC BEVERAGES LAW OF MARYLAND

(I, WE) Breonna Cole, member Doubles Realty HEREBY CERTIFY, That (I am, we are) the owner(s) of the property located at 2556 Madison Ave, Baltimore, City with a Zip Code of 21217, which is named in the present application made to Board of Liquor License Commissioners of Baltimore City under the Alcoholic Beverage Laws of Maryland and assent to the granting of the license applied for, and hereby authorize the State Comptroller, his duly authorized deputies, inspectors and clerks, the Board of Liquor License Commissioners of Baltimore City, its duly authorized agents and employees, and any peace officer of the City of Baltimore and State of Maryland, to inspect and search, without warrant, the premises upon which the business is to be conducted, and any and all parts of the building in which said business is to be conducted, at any and all hours.

[Signature]  
Signature of Landlord

I hereby certify that on the 22<sup>nd</sup> day of June, 2018, before me, the subscriber, a notary public of the State of Maryland, in and for Baltimore City, personally appeared Breonna Cole the landlord/property owner named in this application made oath in due form of law that the matter and facts contained in said application are true and correct.

As witness, my hand and notarial seal.

Notary Signature: Margie Denise Vaughan  
Notary Printed Name: Margie Denise Vaughan

[Notary Seal] My Commission expires August 23, 2020

MARGIE DENISE VAUGHAN  
Notary Public-Maryland  
Baltimore County  
My Commission Expires  
August 23, 2020

The following certificates must be signed by at least 3 persons.

We, the undersigned citizens, real estate owners and registered voters in the City of Baltimore in which the business covered by the present application is to be conducted, certify that the qualifying applicant(s) is/are personally known to us and has been a resident or a taxpayer of Baltimore City and a resident of the State of Maryland for 2 years preceding this application.

Names	Address	Signature	DOB (Month/Year)	Length of time Acquainted with the Applicant(s)
Theresa Lee Johnson	1636 Winford Rd Baltor, Md 21239	Theresa Lee	10/1957	2 yrs
<del>Amani Warren</del>	<del>2430 Linden Ave Baltimore, MD</del>	<del>Amani Warren</del>	<del>9/85</del>	<del>2.5 years</del>
Kinda Kennedy	2541 Madison Avenue Baltimore, MD 21217	Kinda Kennedy	8/1954	2.5 years
Larry Coleman	2536 Madison Ave Baltimore, md. 21217	Larry Coleman	3/1946	2.5 years
Morgan G. Hall Jr.	2109 madison Ave Baltimore md. 21217	Morgan Hall	6/1969	2.5 years

Board of Liquor License Commissioners for the City of Baltimore,  
231 East Baltimore Street, 6<sup>th</sup> Floor, Baltimore, Maryland 21202  
Phone: 410-396-4377 Fax: 410-396-4382

Please note that this is a public document and upon request will be provided to the general members of the public.

RECEIVED

**\*Please present/draw a Floor Plan/Rendering of the Licensed Premises here. If you have a professionally drafted rendering, please attach it to the application.\***

A large, empty rectangular box with a black border, intended for the applicant to draw a floor plan or rendering of the licensed premises. The box occupies most of the page below the instruction.



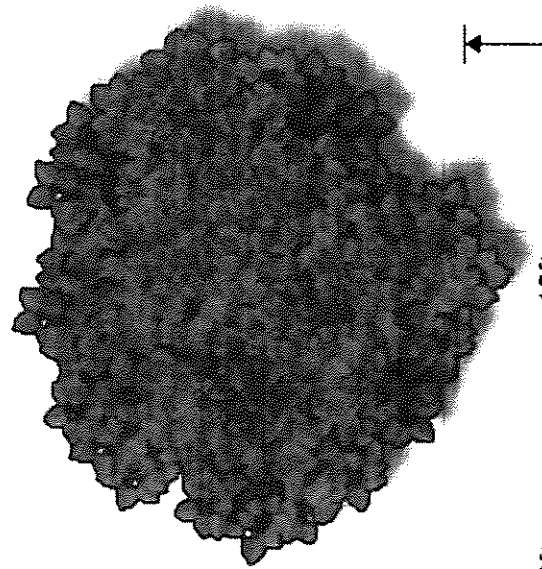
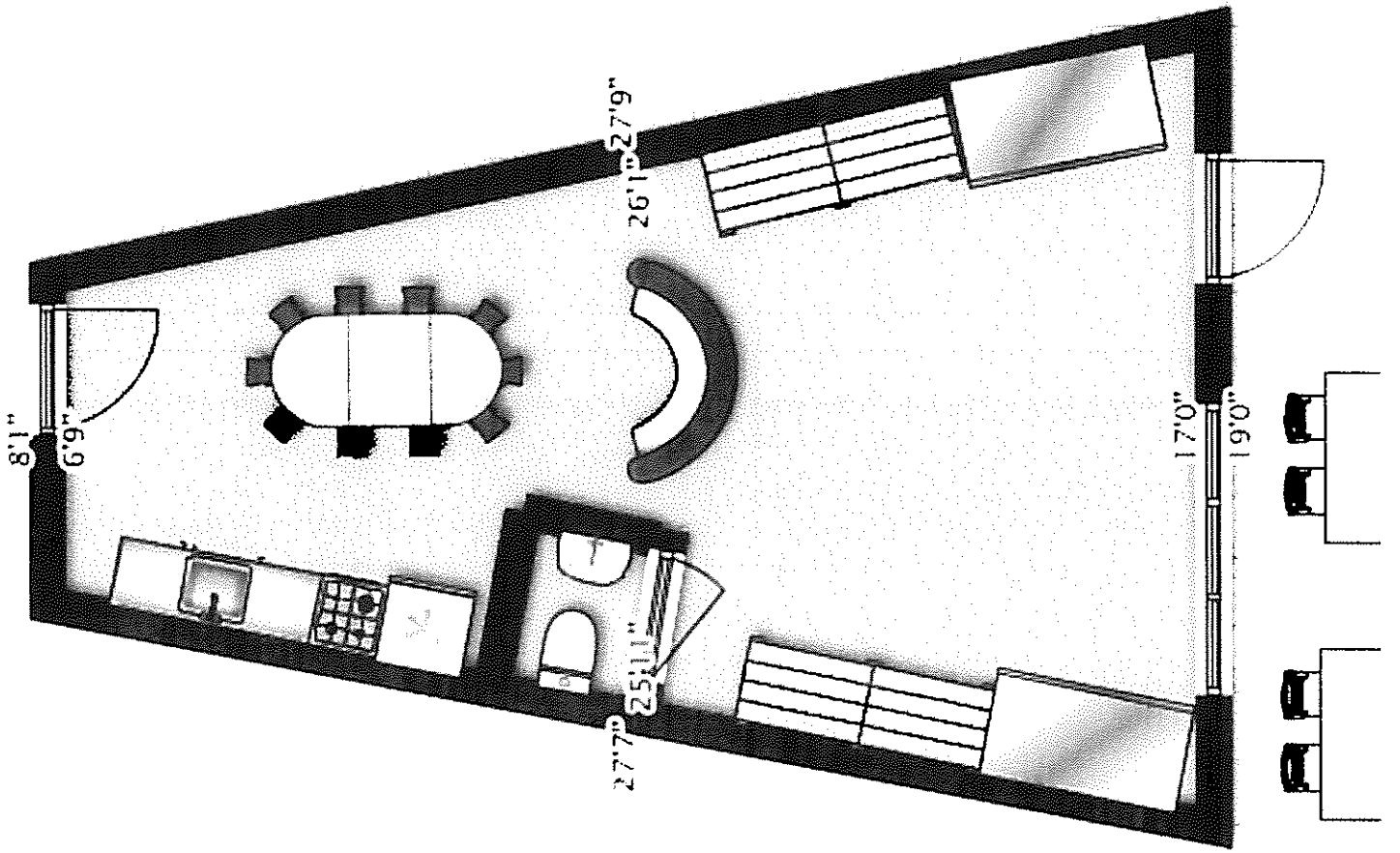

0ft 6ft 12ft



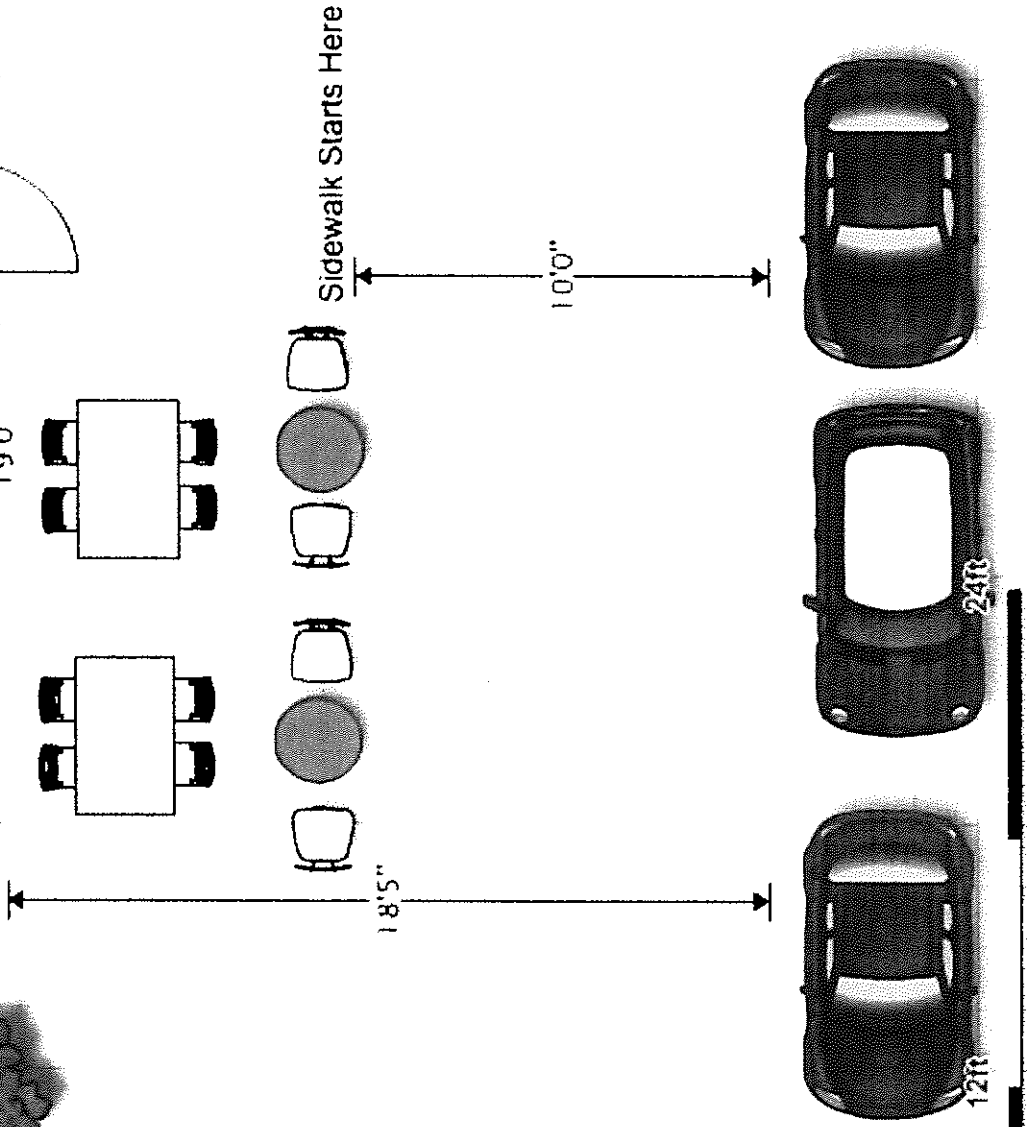
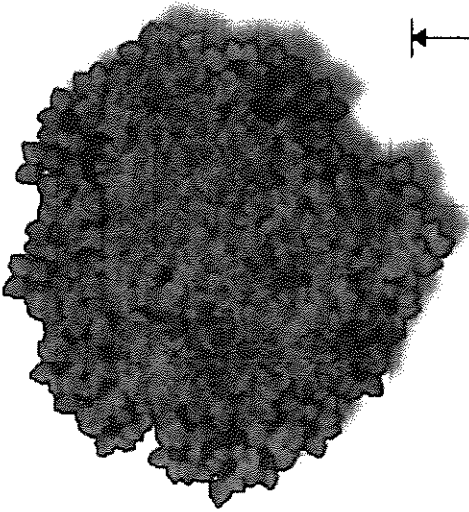
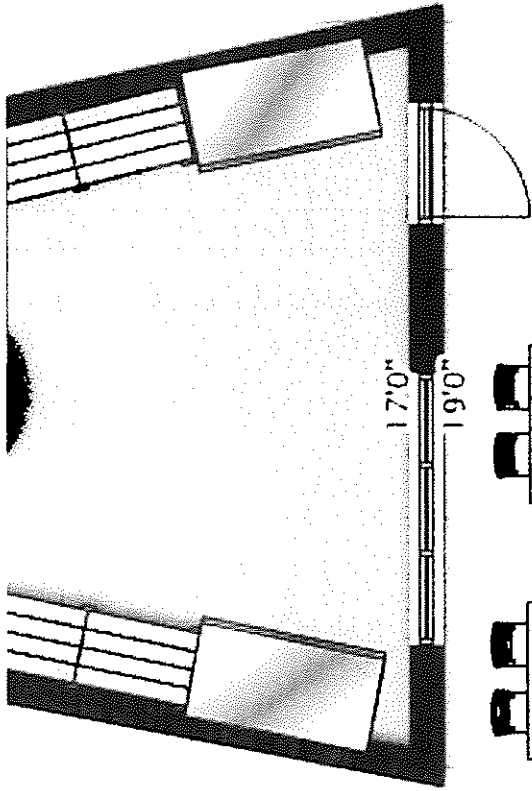

0ft



## Liquor Board System

Version 1.0

Annual-Renewal ▼ | License-Transfer ▼ | One-Day ▼ | Add New License ▼ | Query ▼ | Help ▼

### License Detail

#### License Info

License Num: **WD 039**      Cert Num: **1108**      Fee: **\$165.00**      Status: **Renewed**  
 License Date: 5/1/2018      License Year: 2018  
 CR Number: 01246120  
 Payment Date: 06-29-18

2017 - 2018 TPP Paid   
 2018 Trader's License

[View License Renewal History](#)

### Add Adult Entertainment License

#### Location

Corp Name: **CONTRACT PURCHASER**  
 Trade Name: **ANDY'S FOOD MART**  
 Zone Code: 37  
 Phone: 410-462-6013

Block Num: 2556      Street: MADISON AVENUE  
 City: BALTIMORE      State: MD      Zip: 21217

CR Number: 01246120

Portion of Business Used:  
 RES. N.C.U. APPR. FIRST FLOOR FOR BUSINESS & BASEMENT FOR STORAGE

Restriction:  
 NO BAR TO BE INSTALLED ON PREMISES. PREMISES TO BE PARTITIONED. NO CHILDREN  
 PERMITTED IN THAT PORTION OF PREMISES WHERE ALCOHOLIC BEVERAGES ARE  
 CONSUMED UNLESS ACCOMPANIED BY THEIR PARENTS. LICENSE RESTRICTED TO  
 CLASS "A" HOURS: 6 A.M. - MIDNIGHT. NO SUNDAY SALES.

#### License Owners

First Name	Last Name	Street	City	State	Zip	Action	Change Owner
BREONNA	COLE	2545 MADISON AVE	Baltimore	MD	21217	<input type="button" value="Edit"/>	<input type="button" value="Remove Owner"/>

#### Comments

Date	Comment	Action

06/06/2018	The bounced check paid back on June 6, 2018 Inv. # 112734 \$250.00 and Inv. # 112738 \$30.00.../mb	Delete
02/09/2018	Re-send 2018-2019 Renewal Application to Licensees home addresses.... /sb	Delete
02/09/2018	02-08-18 - Returned To Sender; Not Deliverable As Addressed; Unable To Forward... /sb	Delete
01/26/2018	1/25/2018 - Public Hearing RE: Request for a hardship extension - GRANTED (3-0 vote)..../jr	Delete
12/27/2017	Establishment requested for a Hardship Extension; Letter in file; Invoice # 109230. Pending Public Hearing..... /sb	Delete
07/06/2017	6/29/17- Public Hearing- Application to transfer ownership,outdoor table service- APPROVED (3-0 vote)	Delete
07/06/2017	6/29/17- Public Hearing- Application for a new Class B Beer, Wine & Liquor License , request for outdoor table service- APPROVED (3-0 vote)** request to remove restrictions approved	Delete
04/26/2017	Licensee Chang Ho Kim passed away - removed from license per DKP /kk	Delete
03/01/2004	9/18/97 Public Hearing re: Violation of rule 4.18 re: Failure to have a current traders license.GUILTY \$200 OR 2 DAYS-SUSPENDE- MUST PROVIDE TRADERS LICENSE IN 30 DAYS.	Delete

Print History (Print Card)

License num: WD 039                      Address: 2556 MADISON AVENUE  
 Trade Name: ANDY'S FOOD MART

Comment:

Add Comment

Hold Info

Powered by:



## DOUBLES MARKET & GRILL, LLC: W17973561

General Information

Filing History

Annual Report/Personal Property

### General Information

**Department ID Number:**

W17973561

**Business Name:**

DOUBLES MARKET & GRILL, LLC

**Principal Office:**

2545 MADISON AVE.  
BALTIMORE MD 21217

**Resident Agent:**

BREONNA COLE  
2545 MADISON AVE.  
BALTIMORE MD 21217

**Status:**

ACTIVE

**Good Standing:**

THIS BUSINESS IS IN GOOD  
STANDING

▶ [Order Certificate of Status](#)

**Business Type:**

DOMESTIC LLC

**Business Code:**

20 ENTITIES OTHER THAN  
CORPORATIONS

**Date of Formation/ Registration:**

05/01/2017

**State of Formation:**

MD

**Stock Status:**

N/A

**Close Status:**

N/A

PROPOSED LOCATION: 2556 Madison Ave

## MAP SUMMARY (RECAPITULATION)

TOTAL ESTABLISHMENTS IN MAP AREA 0

"A" BEER & WINE \_\_\_\_\_

"B" BEER & WINE \_\_\_\_\_

"C" BEER & WINE \_\_\_\_\_

"D" BEER & WINE \_\_\_\_\_

"A" BEER, WINE & LIQUOR \_\_\_\_\_

"A-2" BEER, WINE & LIQUOR \_\_\_\_\_

"B" BEER, WINE & LIQUOR \_\_\_\_\_

"C" BEER, WINE & LIQUOR \_\_\_\_\_

"D" BEER, WINE & LIQUOR \_\_\_\_\_

"BD7" BEER, WINE & LIQUOR \_\_\_\_\_

ARENA \_\_\_\_\_

HOTEL/MOTEL \_\_\_\_\_

RACING \_\_\_\_\_

PREPARED BY: [Signature] DATE: 7/25/18

# 2556 Madison Ave.

Licensed Establishments

2556 Madison Ave

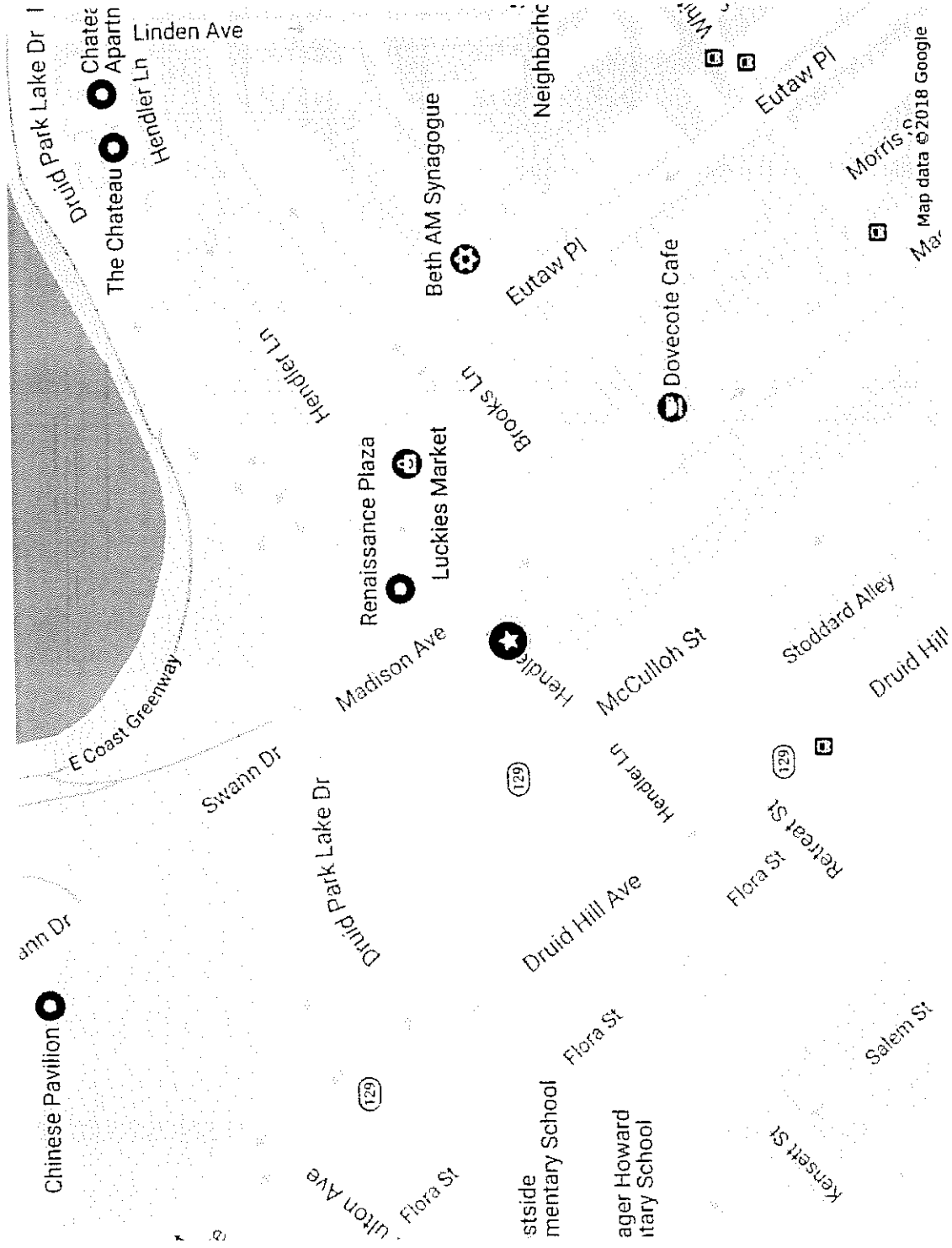

Back

### Board of Liquor License Commissioners

For Baltimore City  
 231 E. Baltimore Street, 6<sup>th</sup> Floor  
 Baltimore, Maryland, 21202-3258

#### POSTING SIGNS REPORT

Applicant(s) Name:	Breonna Cole/Aisha Pew
Address of Premises:	2556 Madison Ave
Inspector:	i:\O#.w\baltime\john.howard
Date Posted:	7/16/2018
Time Posted:	2:45 PM
Date Rechecked:	7/25/2018
Time Rechecked:	11:30 AM
Manager or Owner when sign posted:	

Summary on location of sign posted:

Sign posted exterior front door

Summary on location of sign rechecked:

Sign remained in place for the mandatory period of time

Insert Photo of Sign and location:

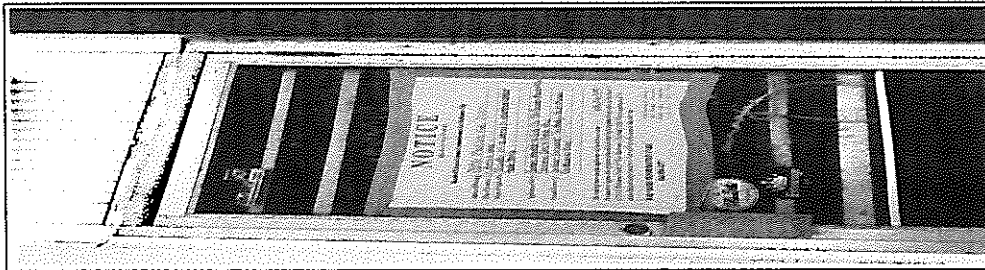



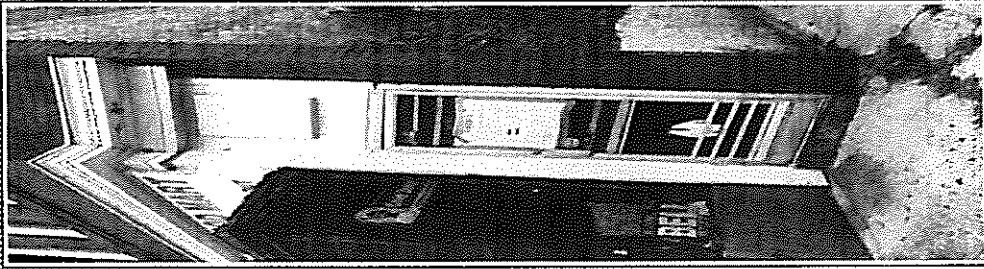

Attach Additional Photos

Submit

[Back](#)

### Board of Liquor License Commissioners

For Baltimore City  
 231 E. Baltimore Street, 6<sup>th</sup> Floor  
 Baltimore, Maryland, 21202-3258

#### INSPECTORS REPORT - TRANSFERS/NEW APPLICATIONS

<i>Licensee Information (Trade Name):</i>	Doubles Market & Grill
<i>Corporation Name:</i>	Doubles Market & Grill LLC
<i>Location Address:</i>	2556 Madison Ave
<i>License Type:</i>	Class "D" Beer, Wine and Liquor <input type="checkbox"/>
<i>Is the establishment open and operating in a safe and sanitary manner? (If not open, not in comments - CLOSED or NOT OPERATING)</i>	No <input checked="" type="checkbox"/>
<i>Is the location within 300 feet of Church and/or School?</i>	No <input checked="" type="checkbox"/>
<i>Date Posted?</i>	7/16/2018 <input type="text"/>
<i>Date Removed?</i>	7/25/2018 <input type="text"/>
<i>Are there any other licensed establishments within a two block radius?</i>	No <input checked="" type="checkbox"/>

*Other licensed locations - Describe/Note:*

*Comments and Follow-up Items(s) (please note any issues or concerns about the location):*

Application for transfer of ownership

*Insert Photo of Sign and location:*

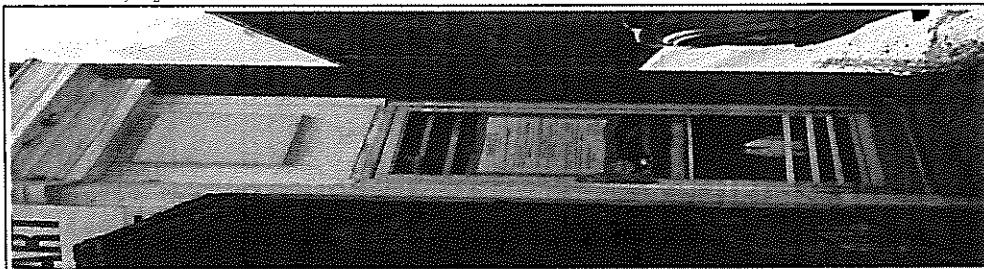

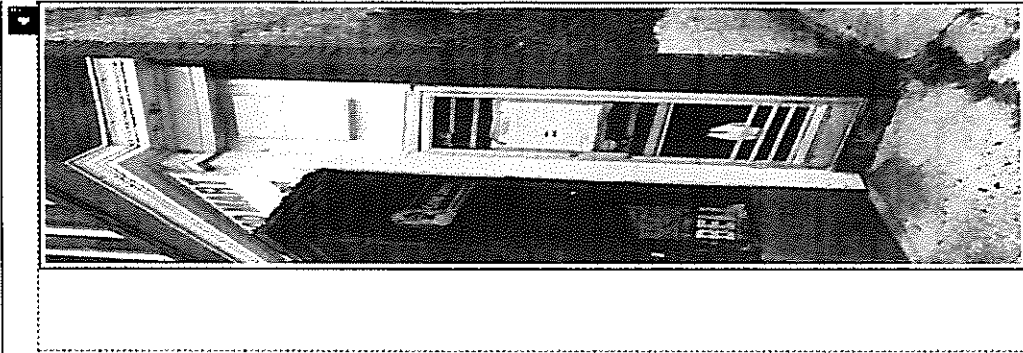

Attach Additional Photos

Inspector Name	Date and Time
<input type="text" value="i:\0#w\baltimore\john.howard"/>	<input type="text" value="7/25/2018"/> <input type="text" value="1:33:36 PM"/>
Name of Licensee (if present)	
<input type="text"/>	
<input type="button" value="Submit"/>	

## BLLC Routine Inspection

*Licensee Information*

Address: 2556 MADISON AVENUE 21217

Trade Name:

Corporation Name:

Type of License: Class " D" Beer and Wine

Date/Time of Inspection:

Manager/Licensee:

*Open/Closed Status*

Open/Closed: Open

Closed Date:

*External Appearance*

Clean and Free of Debris: Satisfactory

*Internal Appearance*

Location of Bar: N/A

Shape of Bar:

Condition of Bar Area/Floors: N/A

Hot Water: N/A

Disinfectant Solution: N/A

Three Compartment/Washer: N/A

*Package Goods/BD7 Checklist*

Bulletproof Partitioning: Yes

Separate Pkg. Goods Dept.: N/A

Separate Pkg. Goods Store: Yes

Bar/Tavern Open and Operating: N/A

Selling Household/Grocery: N/A

Dining Area

Capacity:

Location of Dining Area:

Condition of Dining Area/Floors: N/A

Sanitation: N/A

Menu: N/A

Business Records

Traders License: Yes

Alcohol Awareness Certification Date Issued: 2/12/2015

Employee Records: Yes

Alcohol Beverage Information Invoice Numbers and Date:

Kitchen

Inspector Comments:

Restroom

Inspector Comments:

Public Safety

Exits Marked, Unobstructed: N/A

Fire Capacity:

Outdoor Seating Capacity:

Adult Entertainment - If Applicable

License is Valid: N/A

Dancers Present 18 and older: N/A

Cleanliness of Dressing Room: N/A

Ancillary Services

Live Entertainment (Describe):

[Empty rectangular box for Live Entertainment description]

Outdoor Table Service: N/A

Violations

Violation Issued: No

Violations Noted:

[Empty rectangular box for Violations Noted]

Wrap-Up

Instructions Given to Licensee:

Needs exit sign over top of front door.  
Needs up to date Traders License. (17)

Inspector's Comments:

The establishment is open and operating. Posted poster for transfer of license.

Photo Taken:

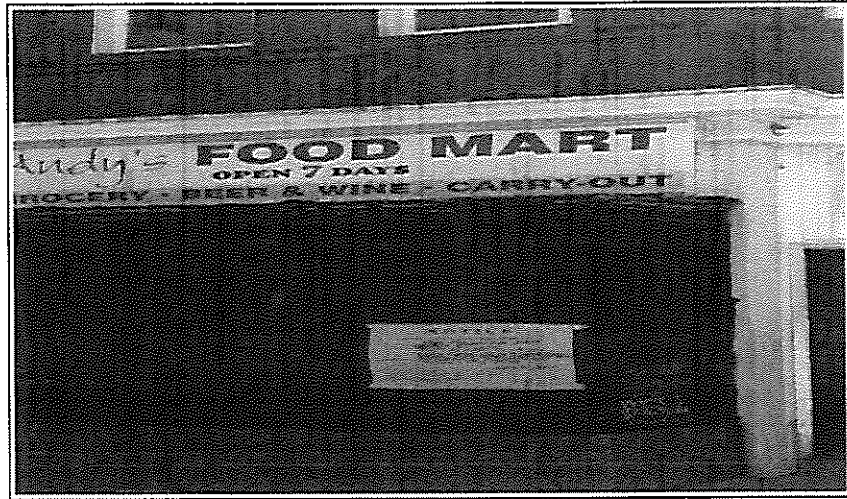

Owner Email:

Submitted by Inspector

Department Of Housing And Community Development  
 Division Of Construction And Building Inspection

**Online Use & Occupancy Permit  
 Application**

Property Address: 2556 MADISON AVE Block/Lot: 3418A/029

Permit No: **USE2018-53338**

**Applicant:**

MARGARET GIORDANO

1001-000000-2600-159400-400540 Filing Fee	50.00
1001-000000-1500-102800-400230 Tax	3.00
1001-000000-2600-158009-400480 Use&Occupancy	45.00

**Owner/Lessee:**

Owner DOUBLES REALTY, LLC  
 2545 MADISON AVENUE BALTIMORE MD 21217  
 Lessee DOUBLES MARKET & GRILL, LLC  
 2556 MADISON AVENUE BALTIMORE MD 21217

Total : **98.00**

**Please pay the Use & Occupancy permit fee  
 before scheduling inspections.**

**Property Use & Occupancy Information:**

Existing Use : (Commercial) Restaurant

Proposed Use : (Commercial) Restaurant

	Dwelling:	Roomming:	Efficiency:
Existing Count:	002	000	000
Proposed Count:	002	000	000

Description	Created	Completed	Assigned To
FIRE DEPARTMENT REFERRAL	06/26/2018		LDZI
HEALTH DEPARTMENT INSPECTION	06/26/2018		JWEL
MINOR PRIVILEGE	06/26/2018		MPRV
One Stop Permit Office Review	06/26/2018		LONG
R32 - RESERVOIR HILL	06/26/2018		CHAY
Application Received		06/26/2018	
Zoning Sign-off	06/26/2018	06/26/2018	

District:101

MINOR PRIVILEGE:

THIS IS NOT A PERMIT. THIS DOCUMENT IS PROOF OF APPLICATION FOR A PERMIT. YOU MUST OBTAIN THE ACTUAL PERMIT OR CERTIFICATE OF OCCUPANCY BEFORE THE BELOW STATED WORK OR USE CAN BEGIN. FOR MORE INFORMATION CONTACT THE ONE STOP SHOP PERMIT CENTER AT 443-984-1809.

USE GROUND FLOOR AS A FOOD STORE/RESTAURANT WITH ACCESSORY OUTDOOR TABLE SERVICE PURSUANT TO BMZ2017-116 (WITH CONDITIONS); WITH TWO DWELLING UNITS ABOVE GROUND FLOOR.

**AFFIDAVIT BY: MARGARET A GIORDANO**

THE OWNER OF THE DESCRIBED PROPERTY FOR THE PROJECT NAMED BELOW HEREBY APPROVED THIS PERMIT APPLICATION AND AGREES TO COMPLY WITH ALL ORDINANCES OF THE MAYOR AND CITY COUNCIL OF BALTIMORE AND TO DO NO WORK NOT SPECIFICALLY COVERED BY THIS APPLICATION. "I DECLARE UNDER PENALTIES OF PERJURY THAT THIS APPLICATION, INCLUDING ANY ACCOMPANYING PLANS, SPECIFICATIONS, ETC. HAS BEEN EXAMINED BY ME AND TO THE BEST OF MY KNOWLEDGE AND BELIEF IS A TRUE, CORRECT AND COMPLETE STATEMENT OF THE WORK TO BE COVERED BY THIS APPLICATION. I ALSO DECLARE THAT I AM THE OWNER OR HAVE SPECIFIC APPROVAL OF THE OWNER TO ACT AS AGENT FOR THIS APPLICATION .

Project Name: 2556 MADISON STREET

Owner First Name:

Role: Agent

Owner Last Name Or Company Name: DOUBLES REALTY, LLC

Applicant: GIORDANO,MARGARET

Phone: [REDACTED]

Project Note:

Address1: [REDACTED]

Address2:

City: [REDACTED]

State: [REDACTED]

Zip: [REDACTED]



September 13, 2018

**Applicant(s):** Hiralda De La Cruz and Victor De La Cruz  
Bryan Restaurant, Inc., T/a Puerto Jarocho Restaurant & Lounge  
4701-03 Eastern Avenue 21224

**Class:** "D" Beer and Wine License

Application to transfer ownership requesting off-premise catering.

(a) **Applicant(s) Information:** (1) Hiralda De La Cruz was born in Dominican Republic in May of 1979. She lives in Dundalk, MD; and (2) Victor De La Cruz was born in Dominican Republic in November of 1974. He lives in Baltimore, MD.

(b) **Ownership Breakdown:** (1) Hiralda De La Cruz (99%); and (2) Victor De La Cruz (1%).

(c) **Purchase Price of Business:** The purchase price of the business was \$25,000 paid in full.

(d) **Qualified Voters:** Rosa Perez, Leonel Musses, and Manuel Garcia are qualified Baltimore City voters.

(e) **Zoning:** Applicant has applied for a USE permit, for the use of the property as a restaurant/ tavern.

(f) **Corporate Standing:** Bryan Restaurant, Inc. is a MD Corporation and as of 8/30/2018 is active and in good standing.

(g) **Posting Report:** The location was posted on 7/23/2018, and checked on 8/1/2018. This meets the 10-day rule. There are 10 licensed liquor establishments in the 4x4 area: "B" BWL-2; and; "BD7" BWL-8.

(h) **Timeline:** On 1/1/2016 the establishment closed. Due to agency mistake the hardship extension was not docketed and approved until 2/8/2018. Applicant had until 8/7/2018 to file a transfer application. Application was filed on 3/7/2018. License is valid.

(i) **Letters of Support/Opposition:** At this time the Board has no letter(s) of opposition or support.

In considering this request, under the provisions of Alcohol Beverages Article 4-210(A) the Board must consider the following factors: 1. The public need and desire for the license; 2. The number and location of existing license holders; 3. The potential effect on existing license holders of the license for which application is made; 4. The potential commonality or uniqueness of the services and products to be offered by the business of the applicant; 5. The impact of the license for which application is made on the health, safety, and welfare of the community, including issues relating to crime, traffic conditions, parking, or convenience; and 6. Any other factor that the local licensing Board considers necessary.

**Board's Decision:**

# Application for Alcoholic Beverages License Board of Liquor License Commissioners for Baltimore City

NEW/TRANSFER/EXPANSION/AMENDMENT(S) APPLICATION FEE - \$600.00

\*\*\*Place cursor on the field to enter text Do Not tab.

INDICATE TYPE OF LICENSE APPLICATION: TRANSFER  NEW  EXPANSION OF PREMISES  AMENDMENT(S)

EXPLANATION OF REQUEST: transfer of ownership, CLASS TYPE: WD

IF NEW LICENSE REQUEST, THEN ADDRESS OF PROPOSED LOCATION: N/A

IF TRANSFER OF OWNERSHIP ONLY, THEN ADDRESS OF CURRENT LICENSE: 4701-03 Eastern Ave.

IF TRANSFER OF OWNERSHIP AND LOCATION, THEN CURRENT ADDRESS OF LICENSED LOCATION: N/A

IF TRANSFER OF OWNERSHIP AND LOCATION, THEN ADDRESS OF PROPOSED RELOCATION: N/A

CORPORATE/LLC/LLP/PARTNERSHIP NAME: Bryon Restaurant, Inc. TRADE NAME: Puerto Jarocho Restaurant & Lounge.

BUSINESS PHONE NUMBER: pending. BUSINESS EMAIL ADDRESS: \_\_\_\_\_

ATTORNEY FOR THE APPLICANT: Melvin J. Kodenski ADDRESS: 19 E. Fayette St. Ste. 400, Balto, MD 21202 PHONE: 410 685-5100

Part of Premises Used (Note: Floors and Areas for Storage): 1st Floor and 2nd Floor and basement for storage.

Live Entertainment provided?  Yes  No What Kind (Ex. DJ, Band, Etc.)? \_\_\_\_\_

Outdoor Table Service Provided?  Yes  No Off Premise Catering of Food and Alcohol?  Yes  No Catering Application filed with BLLC?  Yes  No

Delivery of alcohol?  Yes  No Zoning Receipt or Current Certificate of Occupancy Permit attached to Application?  Yes  No

Please note that as per Alc. Bev. Art. 8 12-1407(A)(2), an application for the issuance or transfer, is not complete unless the applicant has obtained approval and/or verification from the Baltimore Municipal Zoning Administration (BMZA)

1. Applicant A Hiraldia De La Cruz, [Redacted]

(Full name) 300 Pinewood Rd, Dundalk, MD 21222 E-mail (Required) N/A

(Residence) Street 5/79 City F State Dominican Republic Zip Code 16 yrs. (period of residency in Baltimore City)

(Month/Year of Birth) \_\_\_\_\_ (Sex: Male or Female) \_\_\_\_\_ (Place of Birth) \_\_\_\_\_

Check:  Yes  No Have you been a resident and taxpayer of the City of Baltimore for 2 years preceding this application?

Yes  No Are you a registered voter in the City of Baltimore?

2. Applicant B Victor De La Cruz, [Redacted]

(Full name) 5118 Wright Ave, Balto, MD 21205 E-mail (Required) 16 yrs.

(Residence) Street 11/74 City M State Dominican Republic Zip Code \_\_\_\_\_ (period of residency in Baltimore City)

(Month/Year of Birth) \_\_\_\_\_ (Sex: Male or Female) \_\_\_\_\_ (Place of Birth) \_\_\_\_\_

Check:  Yes  No Have you been a resident and taxpayer of the City of Baltimore for 2 years preceding this application?

Yes  No Are you a registered voter in the City of Baltimore?

3. Applicant C

(Full name) \_\_\_\_\_ (Telephone no.) \_\_\_\_\_ E-mail (Required) \_\_\_\_\_

(Residence) Street \_\_\_\_\_ City \_\_\_\_\_ State \_\_\_\_\_ Zip Code \_\_\_\_\_ (period of residency in Baltimore City)

(Month/Year of Birth) \_\_\_\_\_ (Sex: Male or Female) \_\_\_\_\_ (Place of Birth) \_\_\_\_\_

Check:  Yes  No Have you been a resident and taxpayer of the City of Baltimore for 2 years preceding this application?

Yes  No Are you a registered voter in the City of Baltimore?

1. Has the applicant(s) been adjudged guilty of a felony in the State of Maryland or any other?  Yes  No - If yes, indicate applicant and explain.  
Applicant A  B  C

[Redacted]

2. Has the applicant(s) been adjudged guilty of violating the laws governing the sale of any alcoholic beverage or for gambling in any State, including Maryland?  Yes  No - If yes, mark applicant and provide an explanation in adjacent space provided.  
Applicant A  B  C

[Redacted]

3. State whether the applicant(s) has ever been adjudged guilty of any offense against the laws of the State of Maryland, any other State within the United States, or against the United States (Federal Crime)?  Yes  No - If yes, mark applicant and explain.  
Applicant A  B  C

[Redacted]

4. Has the applicant(s) ever had a license for the sale of alcoholic beverages in the State of Maryland?  Yes  No If yes, mark applicant and explain.  
Applicant A  B  C

[Redacted]

5. Has the applicant(s) ever had a liquor license suspended or revoked?  Yes  No If yes, mark applicant and explain.  
Applicant A  B  C

N/A

6. Does the applicant(s) have a financial interest in any other alcoholic beverage business or business for which an alcoholic beverage license has been applied for, granted, and issued?  Yes  No If yes, mark applicant and explain.  
Applicant A  B  C

[Redacted]

7. Do the spouses or children of any of the applicant(s) have a financial interest in any other alcoholic beverages license or business in Baltimore City or any other jurisdiction in the State of Maryland?  Yes  No If yes, mark applicant and explain.  
Applicant A  B  C

[Redacted]

8. Are you financially interested in any other alcoholic beverages license applied, granted or issued?  Yes  No If yes, please explain.  
Applicant A  B  C

[Redacted]

9. Is the licensed premise currently open and operating?  Yes  No If no, then please explain when the establishment ceased operations.

Hardship hearing on 2/8/18. Hardship approved.

10. Do any of the applicant(s) - personally or through an entity - have any indebtedness or other financial obligations to any manufacturer, brewer, distiller, or wholesaler at the time of making this application?  Yes  No If yes, please explain. If yes, please provide information as to the applicant(s) indebted - personally or through an entity - the amount of the indebtedness, and the name of the manufacturer, brewer, distiller, or wholesaler?  
Applicant A  B  C

[Redacted]

11. Please list the following information for the Manager of the establishment to be licensed:

Name	Address	Phone	Email
N/A			

Applicants Applying as Business Entities - (Give name(s) and addresses - in Corporation list all officers (attach list if necessary) or in Limited Liability Company/Partnerships list all authorized persons.) *Please note that all licensees MUST have a FINANCIAL INTEREST in the license applied for as per Alc. Bev. Art. § 4-109 (a)(11). If necessary, please attach a list of the names and address of all outstanding stock holders who at the time of application own more than 5% of the outstanding stock of the corporation and the articles of incorporation, partnership agreement or articles of organization.*

- 1) NAME: Hiralda de la Cruz ADDRESS: 300 Pinewood Rd TITLE: Pres. % OF STOCK HELD: 99%  
 2) NAME: Victor de la Cruz ADDRESS: 5118 Wright Ave TITLE: Sec. % OF STOCK HELD: 1%  
 3) NAME: \_\_\_\_\_ ADDRESS: \_\_\_\_\_ TITLE: \_\_\_\_\_ % OF STOCK HELD: \_\_\_\_\_  
 4) NAME: \_\_\_\_\_ ADDRESS: \_\_\_\_\_ TITLE: \_\_\_\_\_ % OF STOCK HELD: \_\_\_\_\_

*\*Extract from Law: If any affidavit or oath required under the provisions of this Act shall contain any false statements, the offender shall be deemed guilty of perjury. And upon indictment and conviction thereof, shall be subject to penalties provided by Law for that crime.*

**CERTIFICATE OF APPLICANTS:** At least one applicant whose signature appears below certifies that he/she has been a resident and taxpayer of Baltimore City, Maryland for at least two years preceding the filing of this application. Each of said applicants hereby certifies further that if the license applied for is granted, he/she will conform to all State and County laws and regulations relating to the sale of alcoholic beverages, as well as to the rules and regulations of the Board of License Commissioners for Baltimore City, and hereby grants permission to the State Comptroller, his duly authorized deputies, inspectors and clerks, The Board of License Commissioners for Baltimore City, its duly authorized agents and employees, and any peace officer of Baltimore City or the State of Maryland to inspect and search at any and all hours, without warrant, the premises and any and all parts thereof upon and in which said business is to be conducted.

H. de la Cruz  
 Signature of Applicant A

I hereby certify that on the 25th day of Sept., 2017, before me, the subscriber, a notary public of the State of Maryland, personally appeared Hiralda de la Cruz, the applicant(s) named in this renewal application made oath in due form of law that the matter and facts contained in said application are true and correct. As witness, my hand and notarial seal.

Signature: Elaine Pappas  
 Printed Name: Elaine Pappas

[Notary Seal] My Commission expires 11/19/18

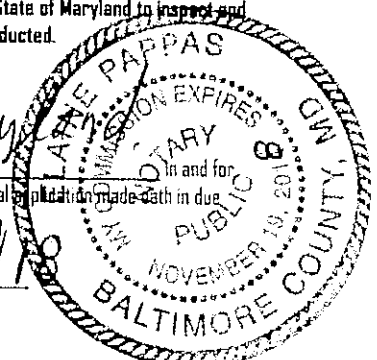

V. de la Cruz  
 Signature of Applicant B

I hereby certify that on the 25th day of Sept., 2017, before me, the subscriber, a notary public of the State of Maryland, personally appeared Victor de la Cruz, the applicant(s) named in this renewal application made oath in due form of law that the matter and facts contained in said application are true and correct. As witness, my hand and notarial seal.

Signature: Elaine Pappas  
 Printed Name: Elaine Pappas

[Notary Seal] My Commission expires 11/19/18

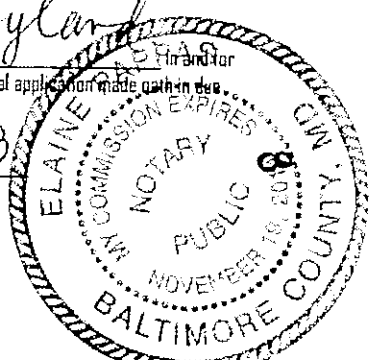

Signature of Applicant C

I hereby certify that on the \_\_\_\_\_ day of \_\_\_\_\_, 20\_\_\_\_, before me, the subscriber, a notary public of the State of \_\_\_\_\_, personally appeared \_\_\_\_\_ the applicant(s) named in this renewal application made oath in due form of law that the matter and facts contained in said application are true and correct. As witness, my hand and notarial seal.

Signature: \_\_\_\_\_ [Notary Seal] My Commission expires \_\_\_\_\_  
 Printed Name: \_\_\_\_\_

Name and Address of the owners of the premise/landlord: Nickolas Bouloubassis  
7414 Longfield Dr. Phone Number: [REDACTED]  
Kingsville, md 21087.

STATEMENT OF OWNER OF PREMISES REQUIRED IN CONNECTION WITH ALCOHOLIC BEVERAGES LAW OF MARYLAND  
 (I, WE) Nickolas Bouloubassis HEREBY  
 CERTIFY That (I am, we are) the owner(s) of the property located at 4901-03 Eastern Ave.  
 Baltimore, City with a Zip Code of 21224, which is named in the present application made to Board of Liquor License  
 Commissioners of Baltimore City under the Alcoholic Beverage Laws of Maryland and assent to the granting of the license applied for,  
 and hereby authorize the State Comptroller, his duly authorized deputies, inspectors and clerks, the Board of Liquor License  
 Commissioners of Baltimore City, its duly authorized agents and employees, and any peace officer of the City of Baltimore and State  
 of Maryland, to inspect and search, without warrant, the premises upon which the business is to be conducted, and any and all parts  
 of the building in which said business is to be conducted, at any and all hours.

I hereby certify that on the 25th day of Sept., 2017, before me, the subscriber, a notary public of the State of Maryland, in and  
 for Balto. Co., personally appeared Nickolas Bouloubassis the  
 applicant(s) named in this renewal application made oath in due form of law that the matter and facts contained in said application are true and correct.

As witness, my hand and notarial seal.

Signature: Elaine Pappas (Notary Seal) My Commission expires 11/18  
 Printed Name: Elaine Pappas

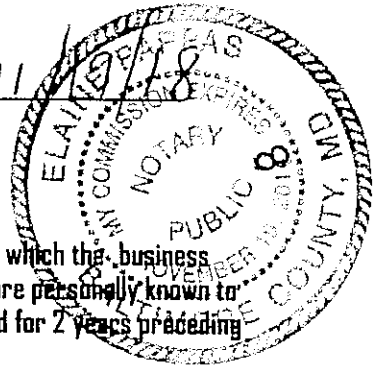

The following certificates must be signed by at least 3 persons.  
 We, the undersigned citizens, real estate owners and registered voters in the City of Baltimore in which the business  
 covered by the present application is to be conducted, certify that the qualifying applicant(s) is/are personally known to  
 us and has been a resident or a taxpayer of Baltimore City and a resident of the State of Maryland for 2 years preceding  
 this application.

	Names	Address	Signature	DOB (Month/Year)	Length of time Acquainted with the Applicant(s)
Good ✓	Rosa Perez	717 Oldham St Baltimore MD 21224	Rosa P [Signature]	12/1/76	30 yrs
Good ✓	LP OUEL-D MURPHY	1614 JOPLIN ST	[Signature]	07-1972	8 yrs
Y	Kimberly DeBorja	518 WRIGHT AVENUE 2105	[Signature]	05-1986	7 yrs
N	Jaysalee Ferrer	937 Rodman way	[Signature]	06-1993	24 yrs
Y	Gelene DeLacme	1103 Newcomb way	[Signature]	12-1976	40 yrs

Board of Liquor License Commissioners for the City of Baltimore,  
 231 East Baltimore Street, 6<sup>th</sup> Floor, Baltimore, Maryland 21202  
 Phone: 410-396-4377 Fax: 410-396-4382

LICENSING COMMISSIONERS

Please note that this is a public document and upon request will be provided to the general members of the public.

RECEIVED

re: 4701-03 Eastern

Name and Address of the owners of the premise/landlord: \_\_\_\_\_ Phone Number \_\_\_\_\_

**STATEMENT OF OWNER OF PREMISES REQUIRED IN CONNECTION WITH ALCOHOLIC BEVERAGES LAW OF MARYLAND**

I, WE: \_\_\_\_\_ HEREBY CERTIFY that  
 (I am, we are) the owner(s) of the property located at \_\_\_\_\_ Baltimore, City with a Zip Code of \_\_\_\_\_  
 which is named in the present application made to Board of Liquor License Commissioners of Baltimore City under the  
 Alcoholic Beverage Laws of Maryland and assert to the granting of the license applied for, and hereby authorize the State Comptroller, his duly  
 authorized deputies, inspectors, and clerks, the Board of Liquor License Commissioners of Baltimore City, its duly authorized agents and  
 employees, and any peace officer of the City of Baltimore and State of Maryland, to inspect and search without warrant, the premises upon which  
 the business is to be conducted and any and all parts of the building in which said business is to be conducted, at any and all hours.

Signature of Landlord \_\_\_\_\_

I hereby certify that on the \_\_\_\_\_ day of \_\_\_\_\_ 20\_\_\_\_ before me, the undersigned notary public of the State of \_\_\_\_\_ in and  
 for \_\_\_\_\_ personally appeared \_\_\_\_\_ the  
 landlord/property owner named in this application made oath in due form of law that the matter and facts contained in said application are true and correct.

As witness, my hand and notarial seal

Notary Signature \_\_\_\_\_ (Notary Seal) My Commission expires: \_\_\_\_\_

Notary Printed Name: \_\_\_\_\_

The following certificates must be signed by at least 3 persons.

We, the undersigned citizens, real estate owners and registered voters in the City of Baltimore in which the business covered by the present application is to be conducted, certify that the qualifying applicant(s) is/are personally known to us and has been a resident or a taxpayer of Baltimore City and a resident of the State of Maryland for 2 years preceding this application.

Names	Address	Signature	DOB (Month/Year)	Length of time Acquainted with the Applicant(s)
Manuel R. Garcia	Marte			
Manuel R. Garcia	811 Ogden St Baltimore MD 21204		05/01/81	2 years
Maria Contreras	4907 Federal St Baltimore MD 21205		2-07-76	7 years

good  
good A.

Board of Liquor License Commissioners for the City of Baltimore  
 231 East Baltimore Street, 8<sup>th</sup> Floor, Baltimore, Maryland 21202  
 Phone: 410-396-4377 Fax: 410-396-4382

Please note that this is a public document and upon request will be provided to the general members of the public.

\*Please present/draw a Floor Plan/Rendering of the Licensed Premises here. If you have a professionally drafted rendering, please attach it to the application.\*

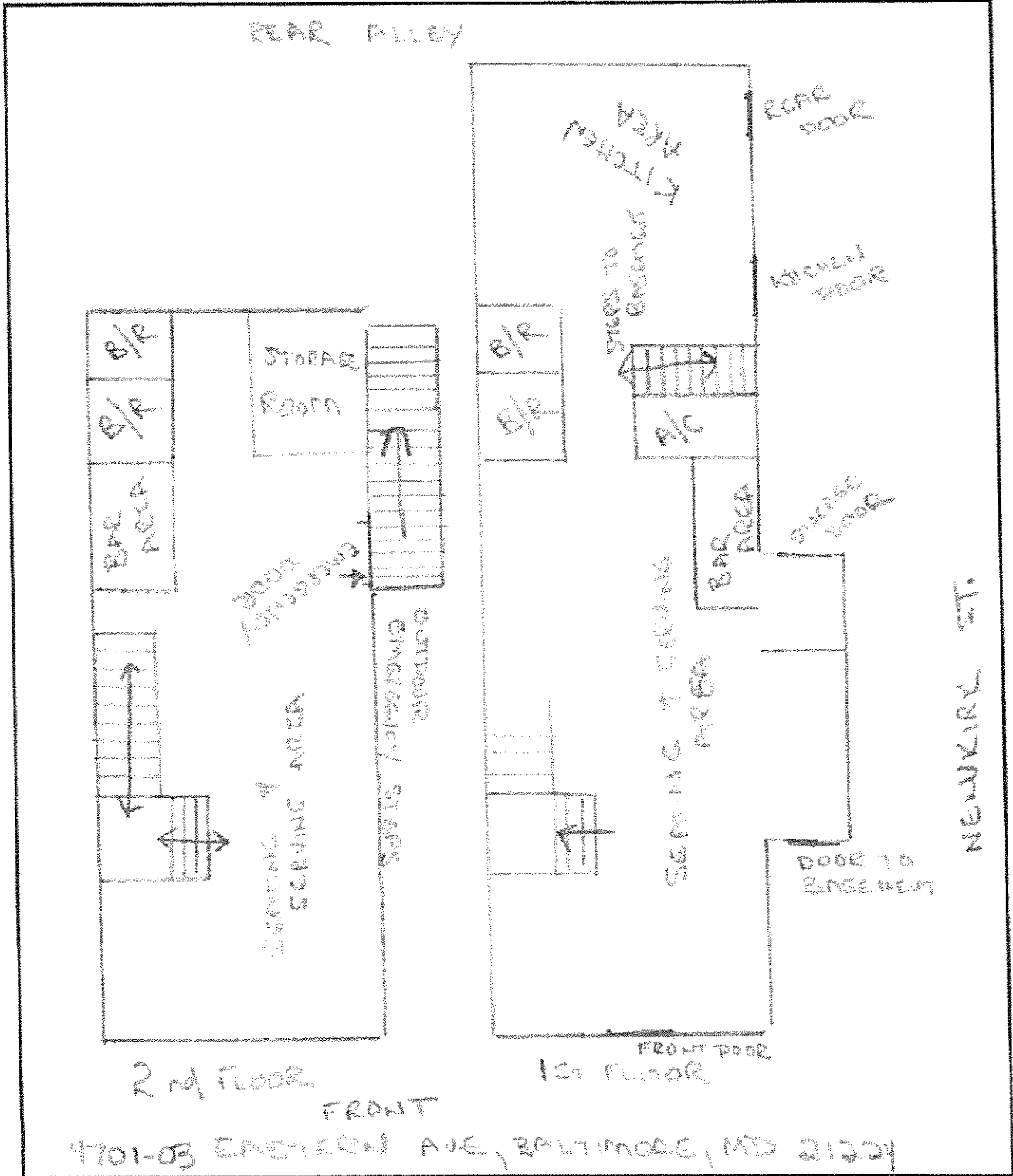



## Liquor Board System

Version 1.0

Annual-Renewal ▼ | License-Transfer ▼ | One-Day ▼ | Add New License ▼ | Query ▼ | Help ▼

### License Detail

[Close the License](#)
[Print License](#)
[Print Renewal Letter](#)
[<< Go Back](#)

#### License Info

License Num: **WD 036**      Cert Num: **1079**      Fee: **\$165.00**      Status: **Renewed**  
 License Date: 5/1/2018      License Year: 2018  
 CR Number: 15634955  
 Payment Date: 05-14-18

2017 - 2018 TPP Paid   
 2018 Trader's License  [Update Info](#)

### Add Adult Entertainment License

[Add New Adult Entertainment License](#)

#### Location

Corp Name: **CONTRACT PURCHASER**  
 Trade Name: **N/A**  
 Zone Code: 11  
 Phone: 443-743-7725

Block Num: 4701-03      Street: EASTERN AVENUE  
 City: BALTIMORE      State: MD      Zip: 21224

CR Number: 15634955

Portion of Business Used:  
 CONTINUE TO USE AS A RESTAURANT AND TAVERN-CHANGE OF LESSEE

Restriction:  
 NO SALE OF BEER LESS THAN A SIX PACK FOR OFF PREMISES CONSUMPTION

[Edit the License Location Info](#)
[Alternate Mailing Address](#)

#### License Owners

First Name	Last Name	Street	City	State	Zip	Action	Change Owner
NICKOLAS	BOULOUBASSIS	7414 LONGFIELD DRIVE	KINGSVILLE	MD	21087	<a href="#">Edit</a>	<a href="#">Remove Owner</a>

#### Comments

Date	Comment	Action



07/11/2018	Application for transfer of ownership requesting off-premise catering filed on behalf of Bryan Restaurant, Inc. T/a Puerto Jarocho Restaurant & Lounge, Hiralda De La Cruz and Victor De La Cruz on 3/7/18 /kk	Delete
02/12/2018	****STATE OF MD TAX HOLD, letter sent to Licensee "Nickolas Bouloubassis" Home Address on February 12, 2018.****/mb	Delete
02/12/2018	State Tax Hold Letter mail was returned to the sender on 02/08/18 "VACANT" ../mb	Delete
02/09/2018	2/8/2018 - Public Hearing RE: Request for a hardship extension - GRANTED (3-0 Vote)...../jr	Delete
01/30/2018	****STATE OF MD TAX HOLD, letter sent to Licensee on January 30, 2018.****/mb	Delete
01/26/2018	Requested for a Hardship Extension per K.Robinson, a letter was submitted; Invoice #109318.... /sb	Delete
06/14/2016	Attorney's office Melvin Kodenski came in office today to file an application for a contract purchaser (Nickolas Bouloubassis) from Asadito's Lounge. Client's lawyer turned in bills of sales, application, transfer of authorization, Two checks ( transfer fee and application fee ) and hardship letter which fellow employee Nadine Davys has as well.....k/r	Delete
06/13/2016	Letter dated 6/10/2016 from Melvin Kodenski indicating that Nickolas Bouloubassis, owner of the real property will file an application as contract purchaser. Letter also states license cease operating January 2016. Letter in file. dkp	Delete
09/11/2015	8/13/2015 Fine PAID \$625 re: Hearing date 8/13/15	Delete
08/18/2015	8/13/15 Public Hearing re: Violation of Rule 4.18 DISMISSED Violation of 4.10(a) DISMISSED Violation of Rule 3.03 GUILTY (3-0 vote) \$500 Fine + \$125 admin fee \$625 Total 30 days to pay	Delete
08/21/2014	7/10/14 Public Hearing re: Application to transfer ownership, request for live entertainment. Board approved transfer. Paid \$ 100 Hearing fee.	Delete
08/12/2014	07/10/2014 Public Hearing re: Application to transfer ownership, request for live entertainment. Board approved the transfer. Paid \$100 hearing fee	Delete
01/28/2014	1/16/2013 Public Hearing re: Request to reopen after being closed for more than 90 days under provisions of Article 2B 10-301(j)(4). Board Conditionally APPROVED request to reopen - licensee must ensure Coporate Charter is in Good Standing.	Delete
04/09/2013	3/28/2013 Public Hearing re: Status of license. Failed to appear; Board ordered a show cause.	Delete
07/03/2012	6/28/2012 Public Hearing re: VIOLATION of Rule 4.18 Illegal conduct. Rule 4.18 GUILTY \$500; suspended.	Delete
12/03/2010	12/2/10 \$125 PAID IN LIEU OF (12/9/10) HEARING #75400	Delete
11/30/2009	11/30/09 \$625 FINE PAID IN FULL #70444	Delete
11/02/2009	10/29/09 Public Hearing re: Violation of rules 4.01 (a),3.03(c ) and rule 4.18.DECISION: RULE 4.01 (a)GUILTY \$500.RULE 3.03(c) GUILTY \$100/SUSPENDE ALL & RULE 4.18 NOT GUILTY.FINE \$500 + \$125 = \$625	Delete

Print History (Print Card)

License num: WD 036                      Address: 4701-03 EASTERN AVENUE  
 Trade Name: N/A

Comment:

Add Comment

**Hold Info**

Powered by:



## BRYAN RESTAURANT, INC.: D18128694

**General Information**

Filing History

Annual Report/Personal Property

### General Information

**Department ID Number:**

D18128694

**Business Name:**

BRYAN RESTAURANT, INC.

**Principal Office:**

4701-03 EASTERN AVE  
BALTIMORE MD 21224

**Resident Agent:**

HIRALDA DE LA CRUZ  
300 PINWOOD ROAD  
DUNDALK MD 21222

**Status:**

INCORPORATED

**Good Standing:**

THIS BUSINESS IS IN GOOD  
STANDING

▶ **Order Certificate of Status**

**Business Type:**

CORPORATION

**Business Code:**

03 ORDINARY BUSINESS - STOCK

**Date of Formation/ Registration:**

07/12/2017

**State of Formation:**

MD

**Stock Status:**

STOCK

**Close Status:**

NO

PROPOSED LOCATION: 4701 Eastern Ave

## MAP SUMMARY (RECAPITULATION)

TOTAL ESTABLISHMENTS IN MAP AREA 10

"A" BEER & WINE \_\_\_\_\_

"B" BEER & WINE \_\_\_\_\_

"C" BEER & WINE \_\_\_\_\_

"D" BEER & WINE \_\_\_\_\_

"A" BEER, WINE & LIQUOR \_\_\_\_\_

"A-2" BEER, WINE & LIQUOR \_\_\_\_\_

"B" BEER, WINE & LIQUOR 7

"C" BEER, WINE & LIQUOR \_\_\_\_\_

"D" BEER, WINE & LIQUOR \_\_\_\_\_

"BD7" BEER, WINE & LIQUOR 3

ARENA \_\_\_\_\_

HOTEL/MOTEL \_\_\_\_\_

RACING \_\_\_\_\_

PREPARED BY: Inspector Perez DATE: 8/1/18

# 4701 Eastern Ave.

## Proposed Location

📍 4701 Eastern Ave

## Licensed Establishments

- 📍 Charro Negro- LB
- 📍 Tom's Bar-LBD7
- 📍 Acropolis Restaurant-LBD7
- 📍 Zorba's Bar & Grill-LB
- 📍 Lou's Bar and Liquors-LBD7
- 📍 El Rincon Troncaleño- LBD7
- 📍 Sportsman's Spot- LBD7
- 📍 Jordy's bar- LBD7
- 📍 Casa Luna- LBD7
- 📍 O'Connor's LBD7

Transfer of Ownership and request to add delivery of Alcoholic beverages

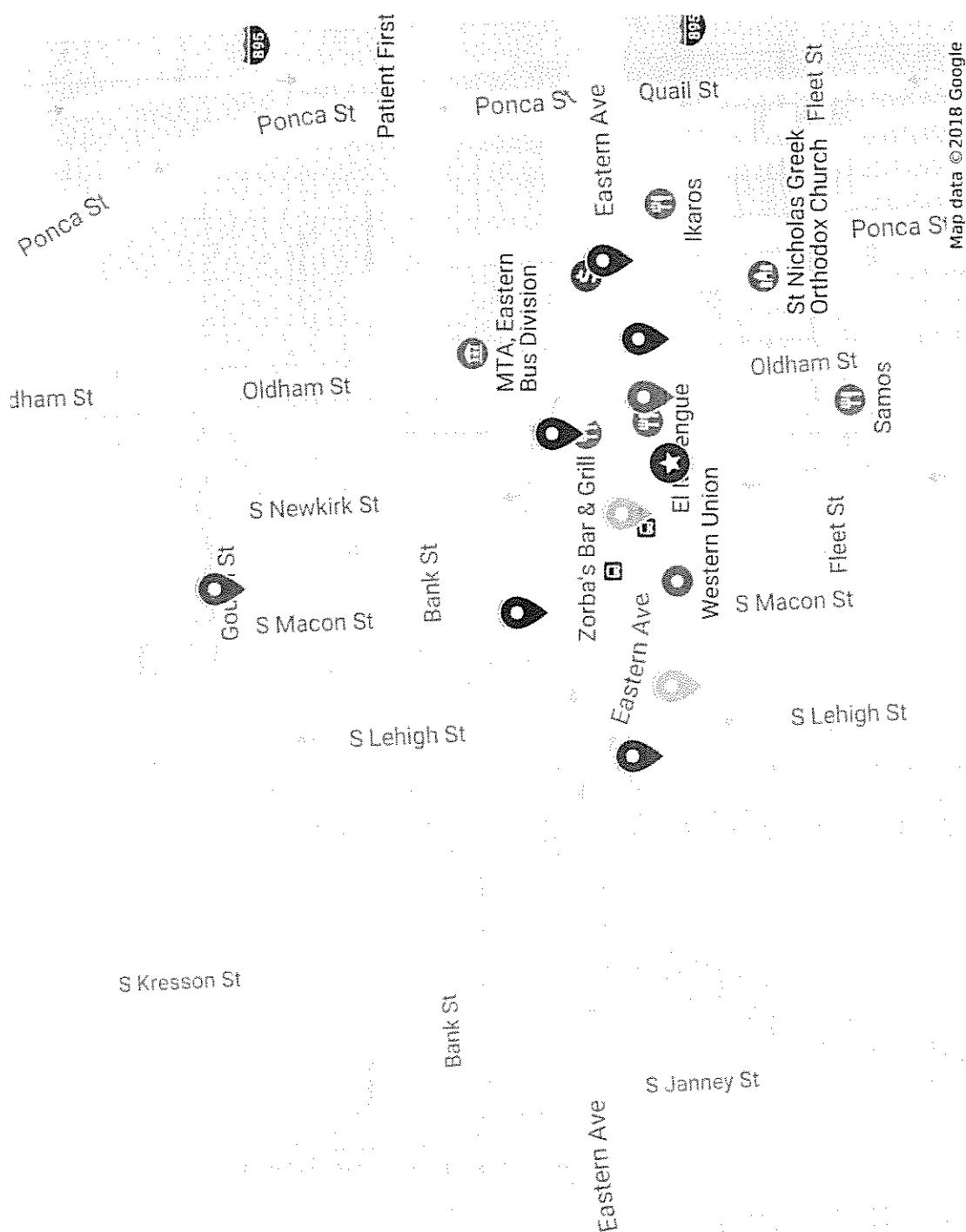

# Board of Liquor License Commissioners

For Baltimore City  
231 E. Baltimore Street, 6<sup>th</sup> Floor  
Baltimore, Maryland, 21202-3258

## INSPECTORS REPORT - TRANSFERS/NEW APPLICATIONS

Licensee Information (Trade Name):	Puerto Jarocho Restaurant & Lounge
Corporation Name:	Bryan Restaurant, Inc
Location Address:	4701 Eastern Ave. Baltimore, MD 21224
License Type:	Class " D" Beer and Wine
Is the establishment open and operating in a safe and sanitary manner? (If not open, not in comments - CLOSED or NOT OPERATING)	No
Is the location within 300 feet of Church and/or School?	No
Date Posted?	7/23/2018
Date Removed?	
Are there any other licensed establishments within a two block radius?	Yes

Other licensed locations - Describe/Note:

See attached map

Comments and Follow-up Items(s) (please note any issues or concerns about the location):

Application filed for transfer of ownership and request to add off premise catering of food and alcoholic beverages.

Insert Photo of Sign and location:

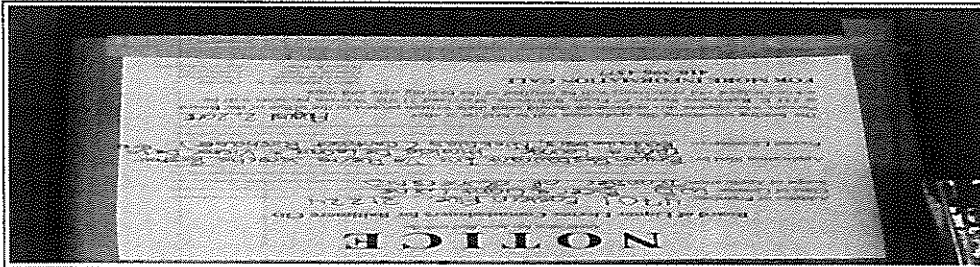

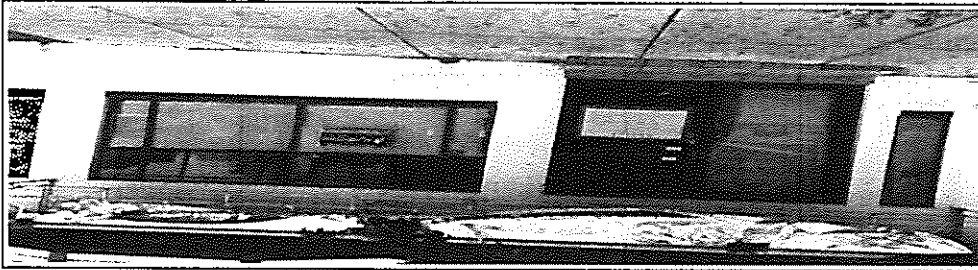
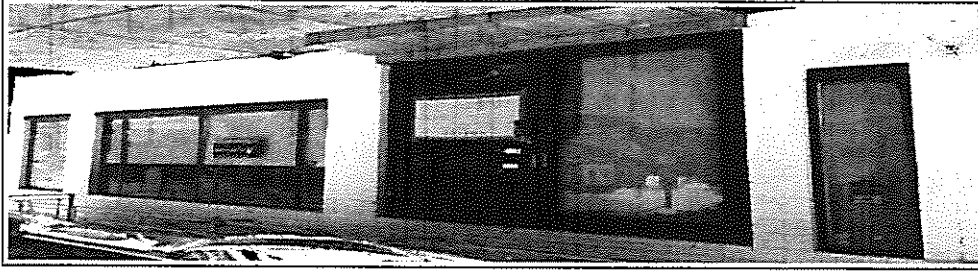

Inspector Name	Date and Time	
<input type="text" value="i:0# w/baltimore\andy.perez"/>	<input type="text" value="7/24/2018"/>	<input type="text" value="11:17:17 AM"/>
Name of Licensee (if present)		
<input type="text"/>		

Board of Liquor License Commissioners

For Baltimore City  
231 E. Baltimore Street, 6<sup>th</sup> Floor  
Baltimore, Maryland, 21202-3258

**POSTING SIGNS REPORT**

<i>Applicant(s) Name:</i>	Hiralda De la Cruz & Victor De la Cruz
<i>Address of Premises:</i>	4701 Eastern Ave. Baltimore, MD 21224
<i>Inspector:</i>	i:\0#w\baltimore\andy.perez
<i>Date Posted:</i>	7/23/2018
<i>Time Posted:</i>	1:00 PM
<i>Date Rechecked:</i>	8/1/2018
<i>Time Rechecked:</i>	1:30 PM
<i>Manager or Owner when sign posted:</i>	

*Summary on location of sign posted.*

Sign posted on front door

*Summary on location of sign rechecked:*

Sign remained as posted for the required 10 days.

*Insert Photo of Sign and location.*

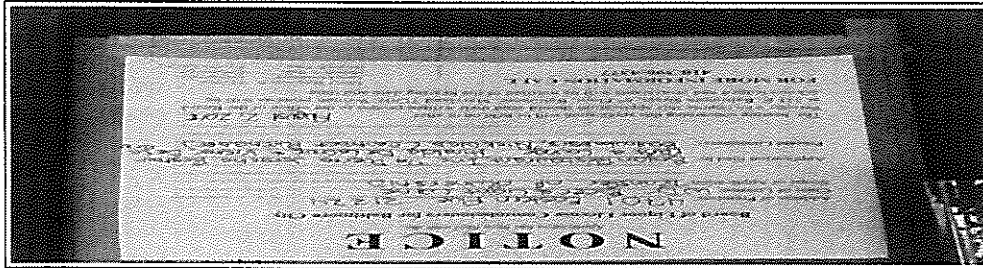

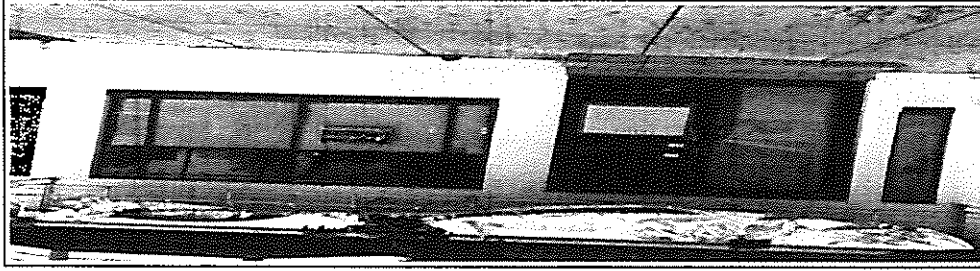



# BLLC Compliance Inspection

## Licensee Information

Address: 4701-03 EASTERN AVENUE 21224

Trade Name: N/A

Corporation Name: CONTRACT PURCHASER

Type of License: Class " D" Beer and Wine

Date/Time of Inspection: 10/18/2017

10:53:54 AM

Manager/Licensee: CLOSED

## Open/Closed Status

Open/Closed: Closed

Closed Date: 1/1/2016

## External Appearance

Clean and Free of Debris: N/A

## Business Records

Traders License: N/A

Alcohol Awareness Certification Date Issued:

## Public Safety

Exits Marked, Unobstructed: N/A

Fire Capacity:

Outdoor Seating Capacity:

## Adult Entertainment - If Applicable

License is Valid: N/A

## Violations

Violation Issued: No

Violations Noted:

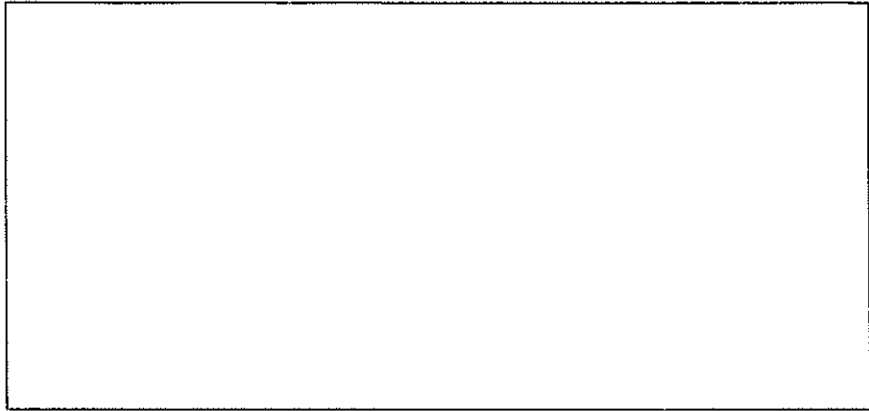

*Wrap Up*

*Instructions Given to Licensee:*

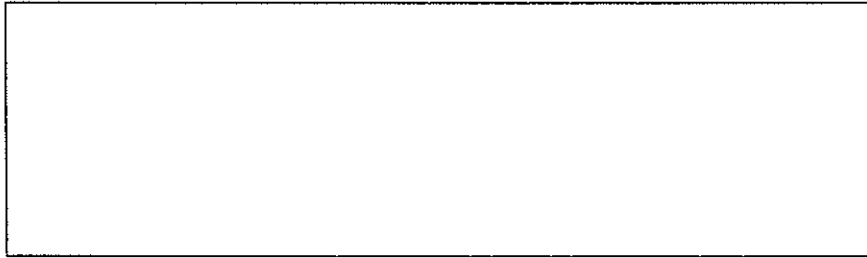

*Inspector's Comments:*

*Establishment ceased operations on or about 01/01/2016. Licensed was transferred to contract purchaser Nickkolas Bouloubassis 6/14/2016*

*Photo Taken:*



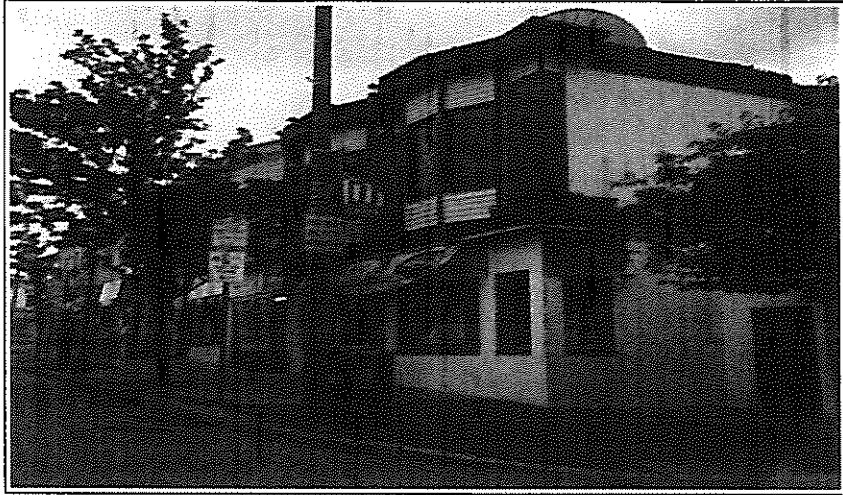

Owner Email:

Submitted by Inspector

# Certificate of Occupancy

THIS WRITTEN INSTRUMENT, WHEN PROPERLY VALIDATED, CONSTITUTES AUTHORITY FOR DOING OR RECEIVING THE THINGS INDICATED BY THE FEES OR CHARGES SHOWN IN THE APPROPRIATE SPACES BELOW. ANY AND ALL THINGS TO BE DONE OR RECEIVED UNDER THIS WRITTEN INSTRUMENT SHALL BE DONE OR RECEIVED IN STRICT COMPLIANCE WITH THE APPLICATION HERETOFORE FILED IN THIS DEPARTMENT FOR THE AUTHORITY CONTAINED HEREIN, INCLUDING ANY AND ALL APPROVED DRAWINGS AND OTHER DATA OR INFORMATION ATTACHED THERETO, AND SUBJECT TO ANY AND ALL LAWS, ORDINANCES, RULES AND REGULATIONS IN EFFECT IN THE CITY OF BALTIMORE AND THE STATE OF MARYLAND. WARNING: IT IS UNLAWFUL TO WORK BETWEEN THE HOURS OF 7:00 PM AND 7:00 AM WITHIN 300 FEET OF A DWELLING.

WARNING: IT IS UNLAWFUL TO CONCEAL ANY WORK UNTIL INSPECTED AND APPROVED BY THIS DEPARTMENT.

WARD	SEC.	BLOCK	LOT	ISSUE DATE	DISTRICT
26	03	6553	001	6/16/14	202

PROPERTY ADDRESS: 4701-4703 EASTERN AVE

OWNER: ANBAC LLC ADDR: 3909 EASTERN AVE 21224-4224

LESSEE: ASADITO'S LOUNGE LLC/IRINA MEREDITH ADDR: 4701-4703 EASTERN AVE BALTIMORE

LAND USE CODES 5810 5814 0000 0000

CONTINUE TO USE AS A RESTAURANT AND TAVERN - CHANGE OF LESSEE

1001-000000-2600-159200-400340 PER. INSP	1001-000000-2600-159000-400480 MISC	1001-000000-2600-158000-400420 CH USE	1001-000000-2600-158301-400490 NEW BLDG.	1001-000000-2600-158302-400490 0 ADDITIONS
		45.00		
1001-000000-2600-158302-400490 ALTERATIONS	1001-000000-2600-158304-400490 REPAIRS	1001-000000-2600-158304-400490 MISC. CONST.	1001-000000-2600-158200-400300 ELECT.	1001-000000-2600-158901-400310 HYDROMIC/STEAM HEAT
1001-000000-2600-158402-400310 DISTRIB/EXH	1001-000000-2600-158902-400310 AIR COND.	1001-000000-2600-158901-400310 CMP TANKS	1001-000000-2600-158905-400310 FIRE	1001-000000-2600-158906-400310 FUEL-BURNING EQUIPMENT
1001-000000-2600-159300-400330 ELEVATOR	1001-000000-2600-159000-400310 PLUMBING	1001-000000-2600-159000-400310 S & E CONTROL	1001-000000-3700-503801-401811 CHAP	1001-000000-1500-102800-400210 TAX
	0.00			3.00
1001-000000-2600-158306-400490 RAZING	1001-000000-2600-159400-400340 FILING FEE	1001-000000-2600-159300-400340 LOW VOLTAGE/TELECOMMUNICATIONS	1001-000000-2600-158000-400350 PENALTY	TOTAL FEES
	50.00			98.00

THE AUTHORITY CONTAINED HEREIN MAY NOT BE VALIDLY EXERCISED UNTIL AND AFTER ALL OF THE FEES APPEARING HEREON HAVE BEEN PAID AND EVIDENCE THEREOF APPEARS IN THIS SPACE.



*Michael Braverman*  
 MICHAEL BRAVERMAN  
 BUILDING OFFICIAL

Please be advised that there is a presumption of lead-based paint in properties constructed prior to 1950. Protect workers and tenants by using the lead-safe work practices found in the Code of Maryland Regulations Section 26.02.07.

THE AUTHORITY CONTAINED HEREIN DOES NOT AUTHORIZE THE PERFORMANCE OF ANY WORK IN, ON, UNDER OR OVER ANY STREET, HIGHWAY, ALLEY, SIDEWALK OR ANY OTHER PUBLIC WAY, UNLESS PERMISSION TO DO SO HAS BEEN FIRST SECURED FROM THE PROPER AUTHORITY.

September 13, 2018

**Applicant(s):** Barbara McKenzie and Stuart Satosky  
Southside Saloon, LLC, T/a Southside Saloon  
430 E. Fort Avenue 21230

**Class:** "BD7" Beer, Wine & Liquor License

Application to transfer ownership.

(a) **Applicant(s) Information:** (1) Barbara McKenzie was born in Baltimore City in May of 1970. She lives in Salisbury, MD; and (2) Stuart Satosky was born in Baltimore, MD in March of 1945. He lives in Baltimore, MD.

(b) **Ownership Breakdown:** (1) Barbara McKenzie (100%); and (2) Stuart Satosky (0%).

(c) **Purchase Price of Business:** The purchase price of the business was \$75,000 to be paid via loan over 3 years.

(d) **Qualified Voters:** John Dworek, Norman Tansill, and Sharon Hartlove are qualified Baltimore City voters.

(e) **Zoning:** Applicant has applied for a USE permit, for the use of the property as a tavern without live entertainment.

(f) **Corporate Standing:** Southside Saloon, LLC is a MD LLC and as of 8/29/2018 is active and in good standing.

(g) **Posting Report:** The location was posted on 8/6/2018, and checked on 8/16/2018. This meets the 10-day rule. There are 3 licensed liquor establishments in the 4x4 area: "A" BWL-1; "B" BWL-1; and "C" BWL-1.

(h) **Timeline:** Last Inspection by BLLC was performed on 8/7/2018. At that time, the establishment was open and operating.

(i) **Letters of Support/Opposition:** At this time the Board has no letter(s) of opposition or support.

In considering this request, under the provisions of Alcohol Beverages Article 4-210(A) the Board must consider the following factors: 1. The public need and desire for the license; 2. The number and location of existing license holders; 3. The potential effect on existing license holders of the license for which application is made; 4. The potential commonality or uniqueness of the services and products to be offered by the business of the applicant; 5. The impact of the license for which application is made on the health, safety, and welfare of the community, including issues relating to crime, traffic conditions, parking, or convenience; and 6. Any other factor that the local licensing Board considers necessary.

**Board's Decision:**

2018 Application for Alcoholic Beverages License Board of Liquor License Commissioners for Baltimore City

NEW/TRANSFER/EXPANSION/AMENDMENT(S) APPLICATION FEE - \$600.00

INDICATE TYPE OF LICENSE APPLICATION: TRANSFER  NEW  EXPANSION OF PREMISES  AMENDMENT(S)

EXPLANATION OF REQUEST: transfer of ownership CLASS TYPE: LBD7

Please select one option and fill out the requested information

A) NEW LICENSE REQUEST: ADDRESS OF PROPOSED LOCATION: N/A

B) TRANSFER OF OWNERSHIP ONLY: ADDRESS OF CURRENT LICENSE: 430 E. Fort Ave; 21230

C) TRANSFER OF OWNERSHIP AND LOCATION: CURRENT ADDRESS OF LICENSED LOCATION: N/A

TRANSFER OF OWNERSHIP AND LOCATION: ADDRESS OF PROPOSED RELOCATION: N/A

CORPORATE/LLC/LLP/PARTNERSHIP NAME: Southside Saloon LLC TRADE NAME: Southside Saloon

BUSINESS PHONE NUMBER: 410 4092448 BUSINESS EMAIL ADDRESS: N/A

ATTORNEY FOR THE APPLICANT: Mel Kodnski ADDRESS: 320 N. Charles St. 1st Fl. 21201 PHONE: 410 685-5100

Part of Premises Used (Note: Floors and Areas for Storage): 1st FL for business and basement for storage Outdoor Table Service Provided?  Yes  No Delivery of alcohol?  Yes  No

Live Entertainment provided?  Yes  No What Kind (Ex. DJ, Band, Etc.): \_\_\_\_\_ Off Premise Catering of Food and Alcohol?  Yes  No

Zoning Receipt or Current Certificate of Occupancy Permit attached to Application?  Yes  No Estimated Seating Capacity: 75

Please note that as per Alc. Bev. Art. 8 (2-1407(A)(2)), an application for the issuance or transfer, is not complete unless the applicant has obtained approval and/or verification from the Baltimore Municipal Zoning Administration (BMZA)

1. Applicant A Barbara McKenzie [Redacted] [Redacted]

(Full name) (Telephone no.) E-mail (Required)

27573 Equestrian Dr. Salisbury MD 21801 N/A

(Residence) Street City State Zip Code (period of residency in Baltimore City)

5/1970 Female Baltimore City

(Month/Year of Birth) (Sex: Male or Female) (Place of Birth)

Check:  Yes  No Have you been a resident and taxpayer of the City of Baltimore for 2 years preceding this application?

Yes  No Are you a registered voter in the City of Baltimore?

2. Applicant B: Stuart Sotosky [Redacted] [Redacted]

(Full name) (Telephone no.) E-mail (Required)

1410 COOKSIDE ST 301-400-21230 21 years

(Residence) Street City State Zip Code (period of residency in Baltimore City)

3-45 M BALTIMORE

(Month/Year of Birth) (Sex: Male or Female) (Place of Birth)

Check:  Yes  No Have you been a resident and taxpayer of the City of Baltimore for 2 years preceding this application?

Yes  No Are you a registered voter in the City of Baltimore?

3. Applicant C

(Full name) (Telephone no.) E-mail (Required)

(Residence) Street City State Zip Code (period of residency in Baltimore City)

(Month/Year of Birth) (Sex: Male or Female) (Place of Birth)

Check:  Yes  No Have you been a resident and taxpayer of the City of Baltimore for 2 years preceding this application?

Yes  No Are you a registered voter in the City of Baltimore?

1. Has the applicant(s) been adjudged guilty of a felony in the State of Maryland or any other?  Yes  No - If yes, indicate applicant and explain.  
Applicant A  B  C

2. Has the applicant(s) been adjudged guilty of violating the laws governing the sale of any alcoholic beverage or for gambling in any State, including Maryland?  Yes  No - If yes, mark applicant and provide explanation in adjacent space provided.  
Applicant A  B  C

3. State whether the applicant(s) has ever been adjudged guilty of any offense against the laws of the State of Maryland, any other State within the United States, or against the United States (Federal Crime)?  Yes  No - If yes, mark applicant and explain.  
Applicant A  B  C

4. Has the applicant(s) ever had a license for the sale of alcoholic beverages in the State of Maryland?  Yes  No If yes, mark applicant and explain (address of location, dates that the applicant was a licensee, and the trade name).  
Applicant A  B  C

A. No      B. on license at 430 E. Fort Ave. For 18 years

5. Has the applicant(s) ever had a liquor license suspended or revoked?  Yes  No If yes, mark applicant and explain.  
Applicant A  B  C

6. Does the applicant(s) have a financial interest in any other alcoholic beverage business or business for which an alcoholic beverage license has been applied for, granted, and issued?  Yes  No If yes, mark applicant and explain (address of location and trade name).  
Applicant A  B  C

7. Do the spouses or children of any of the applicant(s) have a financial interest in any other alcoholic beverages license or business in Baltimore City or any other jurisdiction in the State of Maryland?  Yes  No If yes, mark applicant and explain (address of location and trade name).  
Applicant A  B  C

8. Are you financially interested in any other alcoholic beverages license applied, granted or issued?  Yes  No If yes, please explain.  
Applicant A  B  C

9. Is the licensed premise currently open and operating?  Yes  No If no, then provide date of last day of operation of the establishment.

10. Do any of the applicant(s) - personally or through an entity - have any indebtedness or other financial obligations to any manufacturer, brewer, distiller, or wholesaler at the time of making this application?  Yes  No If yes, please explain. If yes, please provide information as to the applicant(s) indebted - personally or through an entity - the amount of the indebtedness, and the name of the manufacturer, brewer, distiller, or wholesaler?  
Applicant A  B  C

11. Please list the following information for the Manager of the establishment to be licensed:

Name	Address	Phone	Email
Stuart Sotasky	1410 Cooksire St	410-908-2154 410-409-2118	[Redacted]

Applicants Applying as Business Entities - (Give name(s) and addresses - in Corporation list all officers (attach list if necessary) or in Limited Liability Company/Partnerships list all authorized persons.) *Please note that all licensees MUST have a FINANCIAL INTEREST in the license applied for as per Alc. Bev. Art. 5-4-BJ9 (a)(11). If necessary, please attach a list of the names and address of all outstanding stock holders who at the time of application own any stock of the corporation and the articles of incorporation, partnership agreement or articles of organization.*

- 1) NAME: Barbara McKenzie ADDRESS: 27593 Equestrian Dr. Salisbury, MD 21801 TITLE: Member %OF STOCK HELD: 100% *wh/ husband Irving McKenzie*
- 2) NAME: Stuart Sotasky ADDRESS: 1410 Cooksire St 21230 TITLE: Sec. %OF STOCK HELD: 0
- 3) NAME: \_\_\_\_\_ ADDRESS: \_\_\_\_\_ TITLE: \_\_\_\_\_ %OF STOCK HELD: \_\_\_\_\_
- 4) NAME: \_\_\_\_\_ ADDRESS: \_\_\_\_\_ TITLE: \_\_\_\_\_ %OF STOCK HELD: \_\_\_\_\_

*\*Extract from Law: If any affidavit or oath required under the provisions of this Act shall contain any false statements, the offender shall be deemed guilty of perjury. And upon indictment and conviction thereof, shall be subject to penalties provided by Law for that crime.*

**CERTIFICATE OF APPLICANTS:** At least one applicant whose signature appears below certifies that he/she has been a resident and taxpayer of Baltimore City, Maryland for at least two years preceding the filing of this application. Each of said applicants hereby certifies further that if the license applied for is granted, he/she will conform to all State and County laws and regulations relating to the sale of alcoholic beverages, as well as to the rules and regulations of the Board of License Commissioners for Baltimore City, and hereby grants permission to the State Comptroller, his duly authorized deputies, inspectors and clerks, The Board of License Commissioners for Baltimore City, its duly authorized agents and employees, and any peace officer of Baltimore City or the State of Maryland to inspect and search at any and all hours, without warrant, the premises and any and all parts thereof upon and in which said business is to be conducted.

Barbara McKenzie  
Signature of Applicant A

I hereby certify that on the 20th day of June, 2018, before me, the subscriber, a notary public of the State of Maryland in and for County of Harford, personally appeared Barbara McKenzie the applicant(s) named in this application made oath in due form of law that the matter and facts contained in said application are true and correct. As witness, my hand and notarial seal.

Signature: Jacqueline Thomas (Notary Seal) My Commission expires 10/21/19  
Printed Name: Jacqueline Thomas



Stuart Sotasky  
Signature of Applicant B

I hereby certify that on the 20th day of June, 2018, before me, the subscriber, a notary public of the State of Maryland in and for County of Harford, personally appeared Stuart Sotasky the applicant(s) named in this application made oath in due form of law that the matter and facts contained in said application are true and correct. As witness, my hand and notarial seal.

Signature: Jacqueline Thomas (Notary Seal) My Commission expires 10/21/19  
Printed Name: Jacqueline Thomas



Signature of Applicant C

I hereby certify that on the \_\_\_\_\_ day of \_\_\_\_\_, 20\_\_\_\_, before me, the subscriber, a notary public of the State of \_\_\_\_\_ in and for \_\_\_\_\_, personally appeared \_\_\_\_\_ the applicant(s) named in this application made oath in due form of law that the matter and facts contained in said application are true and correct. As witness, my hand and notarial seal.

Signature: \_\_\_\_\_ (Notary Seal) My Commission expires \_\_\_\_\_  
Printed Name: \_\_\_\_\_



Name and Address of the owners of the premise/landlord: 430 E. Fort Ave. Phone Number: [REDACTED]  
IG McKenzia

STATEMENT OF OWNER OF PREMISES REQUIRED IN CONNECTION WITH ALCOHOLIC BEVERAGES LAW OF MARYLAND

(I, WE) Living G. McKenzia Barbara McKenzia HEREBY CERTIFY, That  
 (I am, we are) the owner(s) of the property located at 430 FORT AVE, Baltimore, City with a Zip Code of  
21230, which is named in the present application made to Board of Liquor License Commissioners of Baltimore City under the  
 Alcoholic Beverage Laws of Maryland and assent to the granting of the license applied for, and hereby authorize the State Comptroller, his duly  
 authorized deputies, inspectors and clerks, the Board of Liquor License Commissioners of Baltimore City, its duly authorized agents and  
 employees, and any peace officer of the City of Baltimore and State of Maryland, to inspect and search, without warrant, the premises upon which  
 the business is to be conducted, and any and all parts of the building in which said business is to be conducted, at any and all hours.

Living G. McKenzia  
 Signature of Landlord

I hereby certify that on the 28 day of June, 2018, before me, the subscriber, a notary public of the State of Maryland, in and  
 for City of Balto, personally appeared Living G. McKenzia  
 landlord/property owner named in this application made oath in due form of law that the matter and facts contained in said application are true and correct.

As witness, my hand and notarial seal.  
 Notary Signature: Jacqueline Thomas  
 Notary Printed Name: Jacqueline Thomas

(Notary Seal) My Commission expires 10/21/19

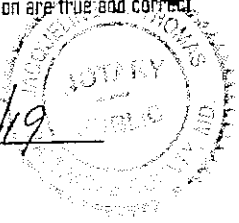

The following certificates must be signed by at least 3 persons.

We, the undersigned citizens, real estate owners and registered voters in the City of Baltimore in which the business covered by the present application is to be conducted, certify that the qualifying applicant(s) is/are personally known to us and has been a resident or a taxpayer of Baltimore City and a resident of the State of Maryland for 2 years preceding this application.

Names	Address	Signature	DOB (Month/Year)	Length of time Acquainted with the Applicant(s)
① John Barry Dwork	607 E. Randall St Baltimore MD 21230	[Signature]	11/1961	4 YRS
② Norman Tarsill, Jr	1438 HEWITT ST BALTO MD 21230	[Signature]	12/1954	7 YRS
③ SHARON HARTLOVE	1630 E CLEMONT ST BALTO MD 21230	[Signature]	5/1952	5 YRS.

Board of Liquor License Commissioners for the City of Baltimore,  
 231 East Baltimore Street, 6<sup>th</sup> Floor, Baltimore, Maryland 21202  
 Phone: 410-396-4377 Fax: 410-396-4382

Please note that this is a public document and upon request will be provided to the general members of the public.

RECEIVED

**\*Please present/draw a Floor Plan/Rendering of the Licensed Premises here. If you have a professionally drafted rendering, please attach it to the application.\***

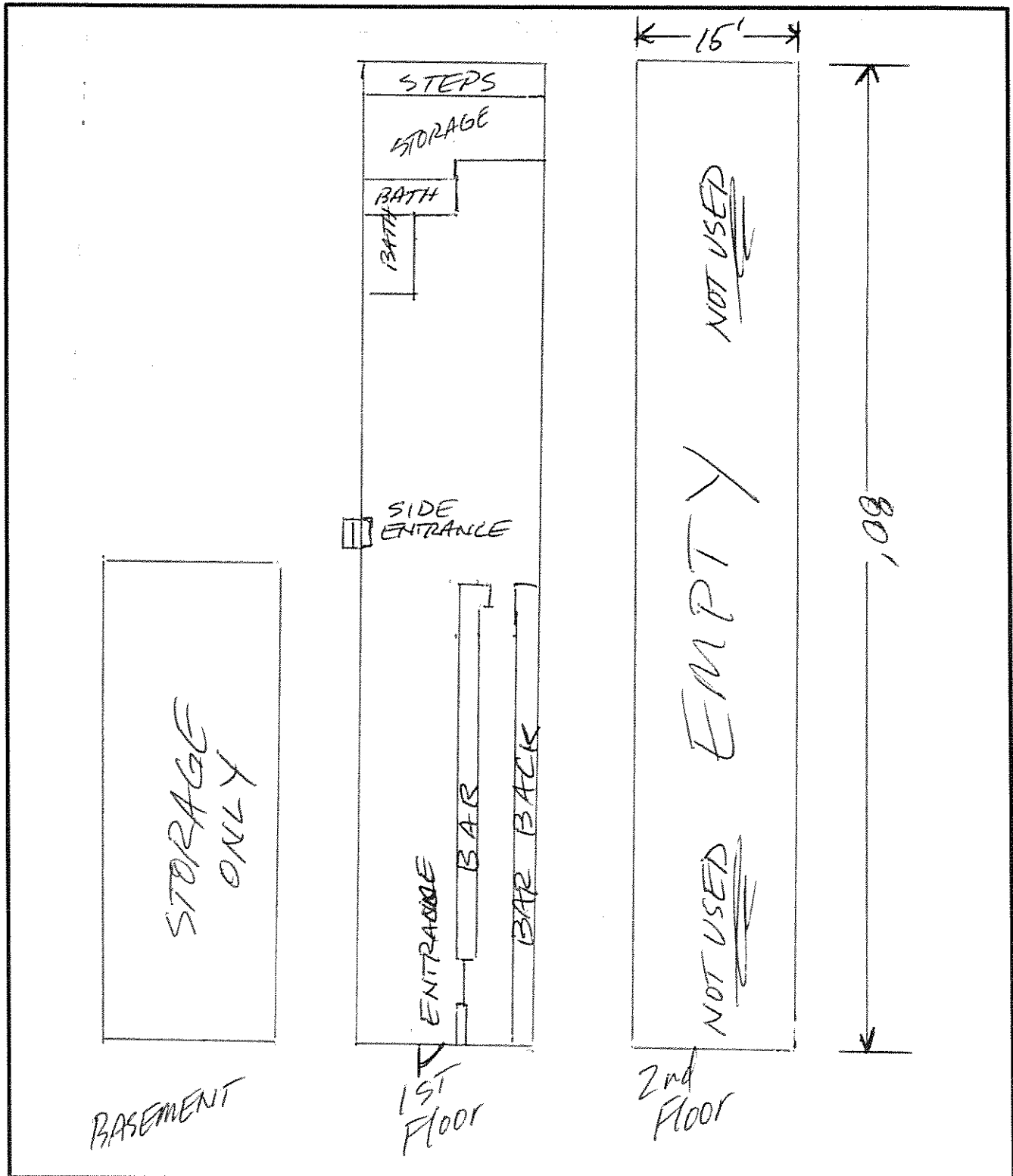



## Liquor Board System

Version 1.0

Annual-Renewal ▼ | License-Transfer ▼ | One-Day ▼ | Add New License ▼ | Query ▼ | Help ▼

### License Detail

Close the License

Print License

Print Renewal Letter

<< Go Back

#### License Info

License Num: **LBD7 041**

Cert Num: **0217**

Fee: **\$1,320.00** Status: **Renewed**

License Date: 5/1/2018

License Year: 2018

CR Number: 09706190

Payment Date: 04-27-18

2017 - 2018 TPP Paid

2018 Trader's License

Update Info

View the License Renewal Schedule

### Add Adult Entertainment License

Add New Adult Entertainment License

#### Location

Corp Name: **SOUTHSIDE SALOON, LLC**

Trade Name: **SOUTHSIDE SALOON**

Zone Code: 8

Phone: 410-547-9995

Block Num: 430

Street: FORT AVENUE EAST

City: BALTIMORE

State: MD

Zip: 21230

CR Number: 09706190

Portion of Business Used:

FIRST FLOOR FOR BUSINESS AND BASEMENT FOR STORAGE

Restriction:

NO PERSONS UNDER 21 ALLOWED ON PREMISES AT ANY TIME.

Edit the License Location Info

Alternate Mailing Address

#### License Owners

First Name	Last Name	Street	City	State	Zip	Action	Change Owner
DEAN F.	MICHAEL	1104 ARCARO COURT	PASADENA	MD	21122	Edit	Remove Owner
STUART A.	SATOSKY	1410 COOKSIE STREET	BALTIMORE	MD	21230	Edit	Remove Owner

#### Comments

--

Date	Comment	Action
04/02/2018	*****RELEASED STATE OF MD TAX HOLD*****... /sb	Delete
01/24/2018	***STATE OF MD TAX HOLD, letter sent to Licensee on January 23, 2018.***/mb	Delete
04/28/2017	*****RELEASED STATE OF MD TAX HOLD***** /sb	Delete
01/17/2017	*****STATE OF MD TAX HOLD, letter sent to Licensee on January 17, 2017.***** /sb	Delete
04/26/2016	***** RELEASED STATE TAX HOLD***** /sb	Delete
03/23/2016	Alcohol Awareness expires on 03/18/2020 (Stuart Satosky)	Delete
01/19/2016	State of MD Tax Hold, letter sent... /sb	Delete
04/27/2015	RELEASED STATE OF MD TAX HOLD..... /sb	Delete
02/02/2015	State of MD Tax Hold, letter sent to merchant on January 23, 2015.	Delete
03/01/2004	12/14/95 Beer sold to minor police cadet CC 9L-8996 i To be handled by Board 3/7/96 Public hearing re: Violation of 4.01(a) (Sale to minor) i Guilty 5 day suspension or \$500 fine - 3/13/96 \$500 fine paid i BT 00941 10/29/97 Alcohol sold to minor CSO CC 9J-20852	Delete

Print History (Print Card)

License num: LBD7 041                      Address: 430 FORT AVENUE EAST  
 Trade Name: SOUTHSIDE SALOON

Comment:

Add Comment

**Hold Info**



## SOUTHSIDE SALOON, LLC,: W05656863

General Information

Filing History

Annual Report/Personal Property

### General Information

**Department ID Number:**

W05656863

**Business Name:**

SOUTHSIDE SALOON, LLC.

**Principal Office:**

430 E. FONT AVE.  
BALTIMORE MD 21230

**Resident Agent:**

STUART SATOSKY  
430 E. FORT AVE  
BALTIMORE MD 21230

**Status:**

REVIVED

**Good Standing:**

THIS BUSINESS IS IN GOOD  
STANDING

» [Order Certificate of Status](#)

**Business Type:**

DOMESTIC LLC

**Business Code:**

20 ENTITIES OTHER THAN  
CORPORATIONS

**Date of Formation/ Registration:**

02/09/2000

**State of Formation:**

MD

**Stock Status:**

N/A

**Close Status:**

N/A

PROPOSED LOCATION: 430 E. 1st Ave.

## MAP SUMMARY (RECAPITULATION)

TOTAL ESTABLISHMENTS IN MAP AREA 3

"A" BEER & WINE \_\_\_\_\_

"B" BEER & WINE \_\_\_\_\_

"C" BEER & WINE \_\_\_\_\_

"D" BEER & WINE \_\_\_\_\_

"A" BEER, WINE & LIQUOR 1

"A-2" BEER, WINE & LIQUOR \_\_\_\_\_

"B" BEER, WINE & LIQUOR 1

"C" BEER, WINE & LIQUOR 1

"D" BEER, WINE & LIQUOR \_\_\_\_\_

"BD7" BEER, WINE & LIQUOR \_\_\_\_\_

ARENA \_\_\_\_\_

HOTEL/MOTEL \_\_\_\_\_

RACING \_\_\_\_\_

PREPARED BY: *John Martore* DATE: 8/10/18

# 430 E. Fort Ave.

## Licensed Establishments

- 📍 430 E Fort Ave
- 📍 Harborview Liquors-A -BWL
- 📍 Rachel's - B-BWL
- 📍 VFW Post 10078 C-BWL

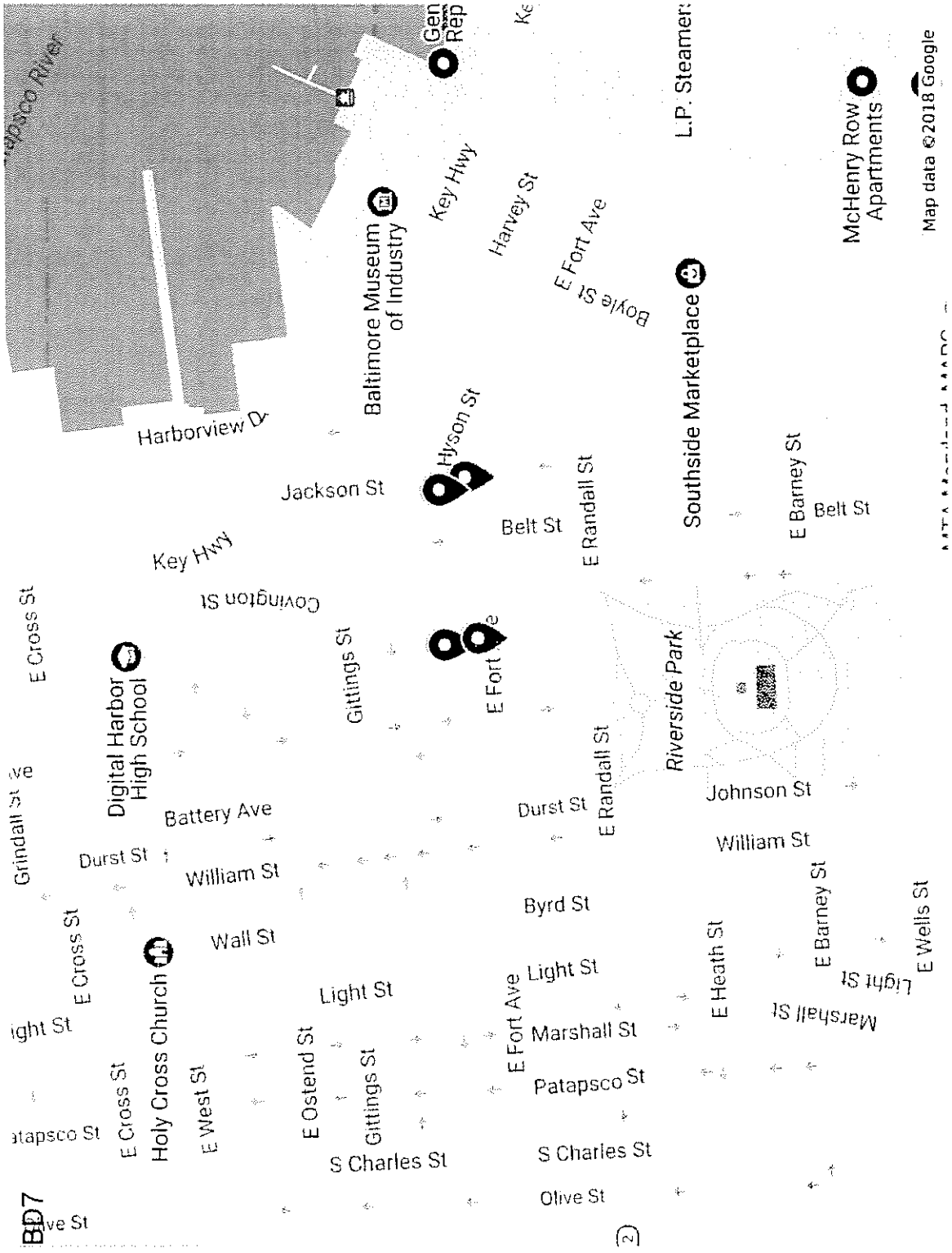

## Board of Liquor License Commissioners

For Baltimore City

231 E. Baltimore Street, 6<sup>th</sup> Floor  
Baltimore, Maryland, 21202-3258

### INSPECTORS REPORT - TRANSFERS/NEW APPLICATIONS

<i>Licensee Information (Trade Name):</i>	Barbara McKenzie/Stuart Satosky t/a Southside Salon
<i>Corporation Name:</i>	Southside Saloon, LLC
<i>Location Address:</i>	430 E. Fort ave.
<i>License Type:</i>	Class "BD7" Beer, Wine and Liquor
<i>Is the establishment open and operating in a safe and sanitary manner? (If not open, not in comments - CLOSED or NOT OPERATING)</i>	Yes
<i>Is the location within 300 feet of Church and/or School?</i>	No
<i>Date Posted?</i>	8/6/2018
<i>Date Removed?</i>	
<i>Are there any other licensed establishments within a two block radius?</i>	Yes

*Other licensed locations - Describe/Note:*

See Map

*Comments and Follow-up Items(s) (please note any issues or concerns about the location):*

Filed an application for transfer of ownership

*Insert Photo of Sign and location:*





Inspector Name		Date and Time	
<input type="text" value="i:0#w/baltimore\joann.martin"/>		<input type="text" value="8/7/2018"/>	<input type="text" value="9:34:17 AM"/>
Name of Licensee (if present)			
<input type="text"/>			

# Board of Liquor License Commissioners

For Baltimore City  
231 E. Baltimore Street, 6<sup>th</sup> Floor  
Baltimore, Maryland, 21202-3258

## POSTING SIGNS REPORT

Applicant(s) Name:	Barbara McKenzie/Stuart Satosky
Address of Premises:	430 E. Fort Ave.
Inspector:	i:\0#w\baltimore\joann.martin
Date Posted:	8/6/2018
Time Posted:	
Date Rechecked:	8/16/2018
Time Rechecked:	
Manager or Owner when sign posted:	Stu Satosky

Summary on location of sign posted.

Front window (exterior)

Summary on location of sign rechecked:

Same Location

Insert Photo of Sign and location:

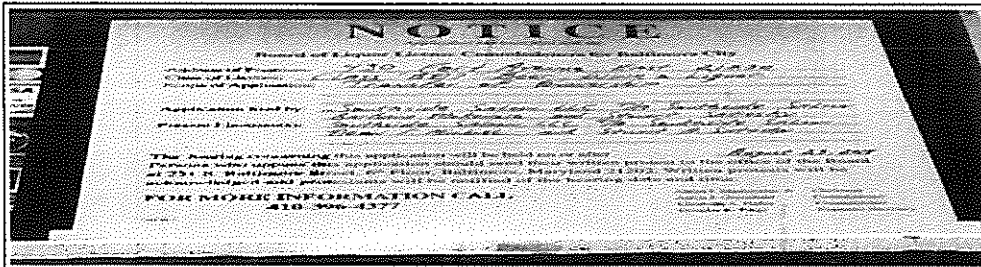

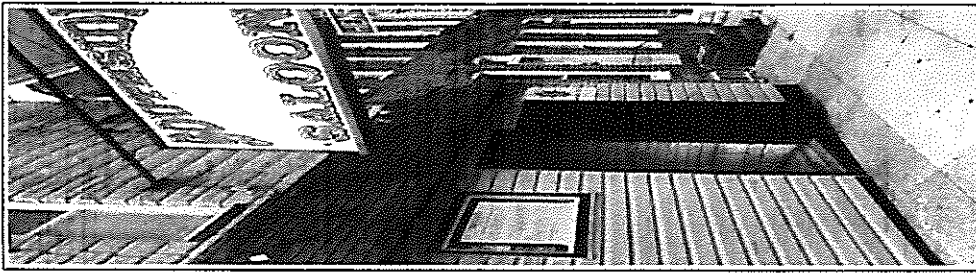

Attach Additional Photos

Submit

# BLLC Routine Inspection

## Licensee Information

Address: 430 FORT AVENUE EAST 21230

Trade Name: SOUTHSIDE SALOON

Corporation Name: SOUTHSIDE SALOON, LLC

Type of License: Class "BD7" Beer, Wine and Liquor

Date/Time of Inspection: 8/7/2018

10:04:31 AM

Manager/Licensee: Stu Satosky

## Open/Closed Status

Open/Closed: Open

Closed Date:

## External Appearance

Clean and Free of Debris: Satisfactory

## Internal Appearance

Location of Bar: Front

Shape of Bar: Straight

Condition of Bar Area/Floors: Satisfactory

Hot Water: Yes

Disinfectant Solution: Yes

Three Compartment/Washer: Yes

## Package Goods/BD7 Checklist

Bulletproof Partitioning: N/A

Separate Pkg. Goods Dept.: N/A

Separate Pkg. Goods Store: N/A

Bar/Tavern Open and Operating: Yes

Selling Household/Gracery: N/A

Dining Area

Capacity:

Location of Dining Area:

Condition of Dining Area/Floors: Satisfactory

Sanitation: Satisfactory

Menu: N/A

Business Records

Traders License: Yes

Alcohol Awareness Certification Date Issued: 3/18/2016

Employee Records: Yes

Alcohol Beverage Information Invoice Numbers and Date:

Kitchen

Inspector Comments:

Restroom

Inspector Comments:

Public Safety

Exits Marked, Unobstructed: Yes

Fire Capacity:

Outdoor Seating Capacity:

Adult Entertainment - If Applicable

License is Valid: N/A

Dancers Present 18 and older: N/A

Cleanliness of Dressing Room: N/A



Ancillary Services

Live Entertainment (Describe):

N/A

Outdoor Table Service: N/A



Violations

Violation Issued: No



Violations Noted:

Wrap Up

Instructions Given to Licensee:

Inspector's Comments:

2018 Traders on display #30388372  
Date of Routine 8/6/18

Photo Taken:

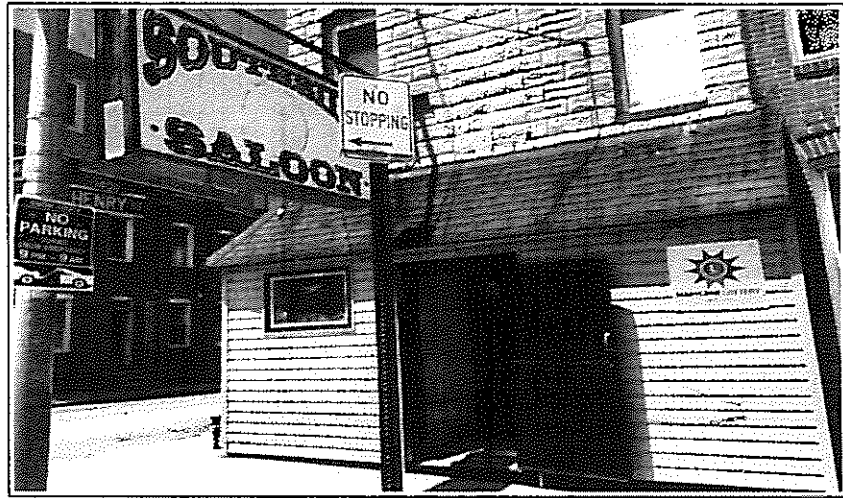

Attach Additional Photos

Owner Email:

Submitted by Inspector

[Update/Resubmit](#)

[Print View](#)

Department Of Housing And Community Development  
Division Of Construction And Building Inspection

No: 000142054

THIS WRITTEN INSTRUMENT, WHEN PROPERLY VALIDATED, CONSTITUTES AUTHORITY FOR DOING OR RECEIVING THE THINGS INDICATED BY THE FEES OR CHARGES SHOWN IN THE APPROPRIATE SPACES BELOW. ANY AND ALL THINGS TO BE DONE OR RECEIVED UNDER THIS WRITTEN INSTRUMENT SHALL BE DONE OR RECEIVED IN STRICT COMPLIANCE WITH THE APPLICATION HERETOFORE FILED IN THIS DEPARTMENT FOR THE AUTHORITY CONTAINED HEREIN, INCLUDING ANY AND ALL APPROVED DRAWINGS AND OTHER DATA OR INFORMATION ATTACHED THERETO, AND SUBJECT TO ANY AND ALL LAWS, ORDINANCES, RULES AND REGULATIONS IN EFFECT IN THE CITY OF BALTIMORE AND THE STATE OF MARYLAND. WARNING: IT IS UNLAWFUL TO WORK BETWEEN THE HOURS OF 7:00 PM AND 7:00 AM WITHIN 300 FEET OF A DWELLING.

WARNING: IT IS UNLAWFUL TO CONCEAL ANY WORK UNTIL INSPECTED AND APPROVED BY THIS DEPARTMENT.

WARD	SEC.	BLOCK	LOT	ISSUE DATE	DISTRICT	MINOR PRIVILEGE	PLANS NO.
24	07	1930	029	4/3/00	901	T091010	

PROPERTY ADDRESS: 0430 E FORT AVE

OWNER: JOHN F VONTRAN

ADDR: 6812 EASTERN AVENUE 21224

LESSEE: STUART SATOSKY

ADDR: 1410 COOKSIE STREET

CONTR:

ADDR:

LIC. NO. :

ELECTRICAL CONTRACTOR:

LIC. NO. :

PLUMBING CONTRACTOR:

LIC. NO. :

GAS FITTER:

LIC. NO. :

HVAC & R CONTR.:

LIC. NO. :

WORK COST	EXPIRATION DATE	LAND USE CODES 1-08
-----------	-----------------	---------------------

(USE) USE PORTION OF PREMISES, FIRST FLOOR, FOR ACONTINUED TAVERN WITHOUT LIVE ENTERTAINMENT. CHANGE OF OPERATORSHIP ONLY.

A-001-139-260-00-000 PER. INSP	A-001-131-260-09-000 MISC	A-001-131-260-09-000 CH. USE	45.00	A-001-132-260-01-000 NEW BLDG.	A-001-132-260-02-000 ADDITIONS
A-001-132-260-03-000 ALTERATIONS	A-001-132-260-04-000 REPAIRS	A-001-132-260-05-000 MISC. CONST.		A-001-133-260-00-000 ELECT.	A-001-134-260-01-000 HYDRONIC/STEAM HEAT
A-001-134-260-02-000 DISTRIB/EXH	A-001-134-260-03-000 AIR COND	A-001-134-260-04-000 DISP TANKS		A-001-134-260-05-000 FIRE	A-001-134-260-06-000 FUEL-BURNING EQUIPMENT
A-001-136-260-00-000 ELEVATOR	A-001-135-260-00-000 PLUMBING	A-001-132-260-07-000 S & E CONTROL	0.00	A-001-868-570-01-000 CHAP	A-001-051-150-00-000 TAX
A-001-132-260-06-000 RAZING	A-001-137-260-00-000 FILING FEE	A-001-132-260-03-000 LOW VOLTAGE/TELECOM		A-001-131-260-09-000 PENALTY	TOTAL FEES
					3.00
					48.00

INSPECTORS REPORT OF INSPECTION

DATE	TYPE OF INSPECTION & NOTE	INITIAL	DATE	TYPE OF INSPECTION & NOTE	INITIAL

COMPLETION DATE

INSPECTORS SIGNATURE