

July 20, 2023

**Applicant(s):** Brandon M. Wylie  
Fleurs d'Ave, Inc., T/a Trade Name Pending  
1200 W. North Avenue 21217

**Class:** "A-7" Beer, Wine & Liquor License

Application for a new Class "A-7" Beer, Wine and Liquor license, requesting delivery of alcoholic beverages.

(a) **Applicant(s) Information:** (1) Brandon M. Wylie was born in Baltimore, MD in November of 1979. He lives in Baltimore, MD.

(b) **Ownership Breakdown:** (1) Brandon M. Wylie (49%); and (2) Ashley Rock Wylie (51%).

(c) **Purchase Price of Business:** N/A

(d) **Qualified Voters:** Jacqueline Holt, Aldonna Wylie, and Atyia Kane are qualified Baltimore City voters.

(e) **Zoning:** Applicant has applied for a USE permit, for the use of the premises as a florist with an A-7 beer, wine and liquor license.

(f) **Corporate Standing:** Fleurs d'Ave, Inc. is a MD Corporation and as of 6/28/2023 is active and in good standing.

(g) **Posting Report:** The location was posted on 6/22/2023 and checked on 7/3/2023. This meets the 10-day rule. There are 3 licensed liquor establishments in the 4x4 area: "A" BWL- 2; and "BD7" BWL- 1.

(h) **Timeline:** N/A

(i) **Letters of Support/Opposition:** At this time the Board has no letter(s) of opposition or support.

In considering this request, under the provisions of Alcohol Beverages Article 4-210(A) the Board must consider the following factors: 1. The public need and desire for the license; 2. The number and location of existing license holders; 3. The potential effect on existing license holders of the license for which application is made; 4. The potential commonality or uniqueness of the services and products to be offered by the business of the applicant; 5. The impact of the license for which application is made on the health, safety, and welfare of the community, including issues relating to crime, traffic conditions, parking, or convenience; and 6. Any other factor that the local licensing Board considers necessary.

**Board's Decision**

2022 Application for Alcoholic Beverages License Board of Liquor License Commissioners for Baltimore City

NEW/TRANSFER/EXPANSION/AMENDMENT(S) APPLICATION FEE - \$600.00

INDICATE TYPE OF LICENSE APPLICATION: TRANSFER  NEW  EXPANSION OF PREMISES  AMENDMENT(S)

EXPLANATION OF REQUEST: Florist will be able to sell Beer wine and liquor CLASS TYPE: A7

*Please select one option and fill out the requested information*

A) NEW LICENSE REQUEST: ADDRESS OF PROPOSED LOCATION: 1200 W. North Ave Baltimore, Md 21217

B) TRANSFER OF OWNERSHIP ONLY: ADDRESS OF CURRENT LICENSE: \_\_\_\_\_

C) TRANSFER OF OWNERSHIP AND LOCATION: CURRENT ADDRESS OF LICENSED LOCATION: \_\_\_\_\_

TRANSFER OF OWNERSHIP AND LOCATION: ADDRESS OF PROPOSED RELOCATION: \_\_\_\_\_

D) AMENDMENT OR EXPANSION REQUEST: ADDRESS OF THE LOCATION: \_\_\_\_\_

CORPORATE/LLC/LLP/PARTNERSHIP NAME: Fleurs d' Ave Inc. TRADE NAME: \_\_\_\_\_

BUSINESS PHONE NUMBER: 4105230864 BUSINESS EMAIL ADDRESS: bwylie@fleursdave.com

ATTORNEY FOR THE APPLICANT: Charles Siegal ADDRESS: 20 S Charles St Bal, Md PHONE: 4105397558

Part of Premises Used (Note: Floors and Areas for Storage): Floral Sales  Outdoor Table Service Provided?  Yes  No Delivery of alcohol?  Yes  No

Live Entertainment provided?  Yes  No What Kind (Ex. DJ Band, Etc.)? \_\_\_\_\_ Off Premise Catering of Food and Alcohol?  Yes  No

Zoning Receipt or Current Certificate of Occupancy Permit attached to Application?  Yes  No Estimated Seating Capacity: 150

*Please note that as per Alc. Bev. Art. § 12-1407(A)(2), an application for the issuance or transfer, is not complete unless the applicant has obtained approval and/or verification from the Baltimore Municipal Zoning Appeals (BMZA)*

1. Applicant A

Brandon M. Wylie \_\_\_\_\_ [REDACTED] \_\_\_\_\_ [REDACTED]

(Full name) (Telephone no.) E-mail (Required)

3530 Derby Shire Circle Windsor Md 21244

(Residence) Street City State Zip Code (period of residency in Baltimore City)

11/1979 male Baltimore MD

(Month/Year of Birth) (Sex: Male or Female) (Place of Birth)

Check:  Yes  No Are you currently a resident of the City of Baltimore?

2. Applicant B

\_\_\_\_\_  
 (Full name) (Telephone no.) E-mail (Required)

\_\_\_\_\_  
 (Residence) Street City State Zip Code (period of residency in Baltimore City)

\_\_\_\_\_  
 (Month/Year of Birth) (Sex: Male or Female) (Place of Birth)

Check:  Yes  No Are you currently a resident of the City of Baltimore?

3. Applicant C

\_\_\_\_\_  
 (Full name) (Telephone no.) E-mail (Required)

\_\_\_\_\_  
 (Residence) Street City State Zip Code (period of residency in Baltimore City)

\_\_\_\_\_  
 (Month/Year of Birth) (Sex: Male or Female) (Place of Birth)

Check:  Yes  No Are you currently a resident of the City of Baltimore?

RECEIVED: ELLO  
 JUN 5 2023 PM 4:33

1. Has the applicant(s) been adjudged guilty of a felony in the State of Maryland or any other?  Yes  No - If yes, indicate applicant and explain.

Applicant A  B  C

2. Has the applicant(s) been adjudged guilty of violating the laws governing the sale of any alcoholic beverage or for gambling in any State, including Maryland?  Yes  No - If yes, mark applicant and provide explanation in adjacent space provided.

Applicant A  B  C

3. State whether the applicant(s) has ever been adjudged guilty of any offense against the laws of the State of Maryland, any other State within the United States, or against the United States (Federal Crime)?  Yes  No - If yes, mark applicant and explain.

Applicant A  B  C

4. Has the applicant(s) ever had a license for the sale of alcoholic beverages in the State of Maryland?  Yes  No If yes, mark applicant and explain (address of location, dates that the applicant was a licensee, and the trade name).

Applicant A  B  C

5. Has the applicant(s) ever had a liquor license suspended or revoked?  Yes  No If yes, mark applicant and explain.

Applicant A  B  C

6. Does the applicant(s) have a financial interest in any other alcoholic beverage business or business for which an alcoholic beverage license has been applied for, granted, and issued?  Yes  No If yes, mark applicant and explain (address of location and trade name).

Applicant A  B  C

7. Do the spouses or dependent children of any of the applicant(s) have a financial interest in any other alcoholic beverages license or business in Baltimore City or any other jurisdiction in the State of Maryland?  Yes  No If yes, mark applicant and explain (address of location and trade name).

Applicant A  B  C

8. Are you financially interested in any other alcoholic beverages license applied, granted or issued?  Yes  No If yes, please explain.

Applicant A  B  C

9. Is the licensed premise currently open and operating?  Yes  No If no, then provide date of last day of operation of the establishment.

10. Do any of the applicant(s) - personally or through an entity - have any indebtedness or other financial obligations to any manufacturer, brewer, distiller, or wholesaler at the time of making this application?  Yes  No If yes, please explain. If yes, please provide information as to the applicant(s) indebted - personally or through an entity - the amount of the indebtedness, and the name of the manufacturer, brewer, distiller, or wholesaler?

Applicant A  B  C

11. Please list the following information for the Manager of the establishment to be licensed:

Name	Address	Phone	Email
Brandon M. Wylie	3530 Derby Shire Circle		

Applicants Applying as Business Entities - (Give name(s) and addresses - in Corporation list all officers (attach list if necessary) or in Limited Liability Company/Partnerships list all authorized persons.) Please note that all licensees MUST have a FINANCIAL INTEREST in the license applied for as per Alc. Bev. Art. § 4-109 (a)(11). If necessary, please attach a list of the names and address of all outstanding stock holders who at the time of application own any stock of the corporation and the articles of incorporation, partnership agreement or articles of organization.

- 1) NAME: Brandon M. Wylie ADDRESS: 3530 Derbyshire Circle W TITLE: owner %OF STOCK HELD: 49  
 2) NAME: Ashley Rock Wylie ADDRESS: 3530 Derby Shire Circle W TITLE: CEO %OF STOCK HELD: 51  
 3) NAME: \_\_\_\_\_ ADDRESS: \_\_\_\_\_ TITLE: \_\_\_\_\_ %OF STOCK HELD: \_\_\_\_\_  
 4) NAME: \_\_\_\_\_ ADDRESS: \_\_\_\_\_ TITLE: \_\_\_\_\_ %OF STOCK HELD: \_\_\_\_\_

\*Extract from Law: If any affidavit or oath required under the provisions of this Act shall contain any false statements, the offender shall be deemed guilty of perjury. And upon indictment and conviction thereof, shall be subject to penalties provided by Law for that crime.

CERTIFICATE OF APPLICANTS: At least one applicant whose signature appears below certifies that he/she is a current resident of Baltimore City, Maryland at the time of filing of this application. Each of said applicants hereby certifies further that if the license applied for is granted, he/she will conform to all State and County laws and regulations relating to the sale of alcoholic beverages, as well as to the rules and regulations of the Board of License Commissioners for Baltimore City, and hereby grants permission to the State Comptroller, his duly authorized deputies, inspectors and clerks, The Board of License Commissioners for Baltimore City, its duly authorized agents and employees, and any peace officer of Baltimore City or the State of Maryland to inspect and search at any and all hours, without warrant, the premises and any and all parts thereof upon and in which said business is to be conducted. If license is issued, the applicants must ensure that at least one licensee remains a resident of Baltimore City throughout the duration of this license.

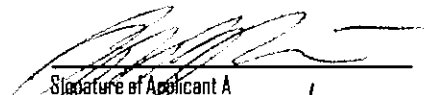

Signature of Applicant A

I hereby certify that on the 2nd day of June, 2023, before me, the subscriber, a notary public of the State of Maryland in and for Baltimore County personally appeared Brandon M. Wylie the applicant(s) named in this application made oath in due form of law that the matter and facts contained in said application are true and correct. As witness, my hand and notarial seal.

Signature: Pamela Carrington  
 Printed Name: Pamela Carrington

(Notary Seal)

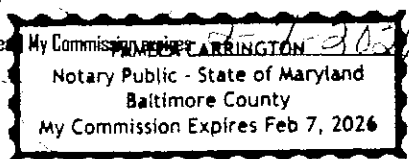

Signature of Applicant B

I hereby certify that on the \_\_\_\_\_ day of \_\_\_\_\_, 20\_\_\_\_, before me, the subscriber, a notary public of the State of \_\_\_\_\_ in and for \_\_\_\_\_, personally appeared \_\_\_\_\_ the applicant(s) named in this application made oath in due form of law that the matter and facts contained in said application are true and correct. As witness, my hand and notarial seal.

Signature: \_\_\_\_\_ (Notary Seal) My Commission expires \_\_\_\_\_

Printed Name: \_\_\_\_\_

Signature of Applicant C

I hereby certify that on the \_\_\_\_\_ day of \_\_\_\_\_, 20\_\_\_\_, before me, the subscriber, a notary public of the State of \_\_\_\_\_ in and for \_\_\_\_\_, personally appeared \_\_\_\_\_ the applicant(s) named in this application made oath in due form of law that the matter and facts contained in said application are true and correct. As witness, my hand and notarial seal.

Signature: \_\_\_\_\_ (Notary Seal) My Commission expires \_\_\_\_\_

Printed Name: \_\_\_\_\_

Name and Address of the owners of the premise/landlord: Brandon M. Wylie Phone Number: [REDACTED]

**STATEMENT OF OWNER OF PREMISES REQUIRED IN CONNECTION WITH ALCOHOLIC BEVERAGES LAW OF MARYLAND**

(I, WE) Brandon M. Wylie HEREBY CERTIFY, That (I am, we are) the owner(s) of the property located at 1200 W. North Ave, Baltimore, City with a Zip Code of 21217, which is named in the present application made to the Board of Liquor License Commissioners of Baltimore City under the Alcoholic Beverage Laws of Maryland and assent to the granting of the license applied for, and hereby authorize the State Comptroller, his duly authorized deputies, inspectors and clerks, the Board of Liquor License Commissioners of Baltimore City, its duly authorized agents and employees, and any peace officer of the City of Baltimore and State of Maryland, to inspect and search, without warrant, the premises upon which the business is to be conducted, and any and all parts of the building in which said business is to be conducted, at any and all hours.

[Signature]  
Signature of Owner of the Property

I hereby certify that on the 2nd day of June, 2023 before me, the subscriber, a notary public of the State of Maryland, in and for Baltimore City personally appeared Brandon M. Wylie the landlord/property owner named in this application made oath in due form of law that the matter and facts contained in said application are true and correct.

As witness, my hand and notarial seal.

Notary Signature: Pamela Carrington  
Notary Printed Name: Pamela Carrington

[Notary Seal] My Commission expires 2-7-2026

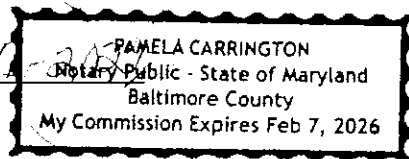

**The following certificates must be signed by at least 3 persons.**

We, the undersigned citizens, real estate owners and registered voters in the City of Baltimore in which the business covered by the present application is to be conducted. We certify that the qualifying applicant(s) is/are personally known to us and is a resident of Baltimore City and a resident of the State of Maryland at the time of this application.

Names	Address	Signature	DOB (Month/Year)	Length of time Acquainted with the Applicant(s)
<u>Tasha Wylie</u>	<u>206 S Augusta Ave Baltimore MD 21229</u>	<u>[Signature]</u>	<u>4/82</u>	<u>10 yrs</u>
<u>Destiny Barnes</u>	<u>2716 Virginia Ave Baltimore MD 21215</u>	<u>[Signature]</u>	<u>07/94</u>	<u>5 yr</u>
<u>Albert P. Wylie</u>	<u>2325 Washington St Baltimore MD 21216</u>	<u>[Signature]</u>	<u>07/46</u>	<u>43 yr</u>

Board of Liquor License Commissioners for the City of Baltimore  
1 North Charles Street, Suite 1500, Baltimore, Maryland 21201  
Phone: 410-396-4377 Fax: 410-396-4382

Please note that this is a public document and upon request will be provided to the general members of the public.

Name and Address of the owners of the premise/landlord: Brandon M. Wylie Phone Number: [REDACTED]

**STATEMENT OF OWNER OF PREMISES REQUIRED IN CONNECTION WITH ALCOHOLIC BEVERAGES LAW OF MARYLAND**

(I, WE) Brandon M. Wylie HEREBY CERTIFY, That (I am, we are) the owner(s) of the property located at 1200 W. North Ave, Baltimore, City with a Zip Code of 21217, which is named in the present application made to the Board of Liquor License Commissioners of Baltimore City under the Alcoholic Beverage Laws of Maryland and assent to the granting of the license applied for, and hereby authorize the State Comptroller, his duly authorized deputies, inspectors and clerks, the Board of Liquor License Commissioners of Baltimore City, its duly authorized agents and employees, and any peace officer of the City of Baltimore and State of Maryland, to inspect and search, without warrant, the premises upon which the business is to be conducted, and any and all parts of the building in which said business is to be conducted, at any and all hours.

[Signature]  
Signature of Owner of the Property

I hereby certify that on the 2<sup>nd</sup> day of June, 2023 before me, the subscriber, a notary public of the State of Maryland, in and for Baltimore personally appeared Brandon M. Wylie the landlord/property owner named in this application made oath in due form of law that the matter and facts contained in said application are true and correct.

As witness, my hand and notarial seal.

Notary Signature: [Signature]  
Notary Printed Name: Pamela Carrington

[Notary Seal] My Commission expires 2<sup>nd</sup> Feb 2026  
**PAMELA CARRINGTON**  
 Notary Public, State of Maryland  
 Baltimore County  
 My Commission Expires Feb 7, 2026

The following certificates must be signed by at least 3 persons.

We, the undersigned citizens, real estate owners and registered voters in the City of Baltimore in which the business covered by the present application is to be conducted. We certify that the qualifying applicant(s) is/are personally known to us and is a resident of Baltimore City and a resident of the State of Maryland at the time of this application.

Names	Address	Signature	DOB (Month/Year)	Length of time Acquainted with the Applicant(s)
<u>Aldonna R Wylie</u>	<u>2319 DuKeland St Baltimore MD 21216</u>	<u>[Signature]</u>	<u>03/47</u>	<u>40 yrs</u>
<u>Jacqueline Holt</u>	<u>4218 Norfolk Ave Baltimore, MD 21216</u>	<u>[Signature]</u>	<u>09/57</u>	<u>20 yrs</u>
<u>Alyia Kane</u>	<u>1646 Gbneagle rd Baltimore, MD 21239</u>	<u>[Signature]</u>	<u>05/81</u>	<u>28 yrs</u>

Board of Liquor License Commissioners for the City of Baltimore  
 1 North Charles Street, Suite 1500, Baltimore, Maryland 21201  
 Phone: 410-396-4377 Fax: 410-396-4382

Please note that this is a public document and upon request will be provided to the general members of the public.

Revised January 2022









**B&B CONSULTANTS**  
 100 NORTH ANKAS BLDG. #201  
 100 NORTH ANKAS BLDG. #201  
 100 NORTH ANKAS BLDG. #201  
 100 NORTH ANKAS BLDG. #201

**CLIENT**  
 FLEURS D'AVE BOUTIQUE  
 100 NORTH ANKAS BLDG. #201  
 100 NORTH ANKAS BLDG. #201  
 100 NORTH ANKAS BLDG. #201

**PROJECT**  
 FLEURS D'AVE BOUTIQUE  
 INTERIOR TENANT IMPROVEMENT  
 EXTERIOR ELEVATIONS - DEMOLITION

**DATE**  
 10/20/2017  
 10/20/2017  
 10/20/2017

**SCALE**  
 1/8" = 1'-0"  
 1/8" = 1'-0"  
 1/8" = 1'-0"

**PROJECT LOCATION**  
 100 NORTH ANKAS BLDG. #201  
 100 NORTH ANKAS BLDG. #201  
 100 NORTH ANKAS BLDG. #201

**PROJECT CONTACT**  
 JEFFREY B. BROWN  
 100 NORTH ANKAS BLDG. #201  
 100 NORTH ANKAS BLDG. #201

**PROJECT CONTACT**  
 JEFFREY B. BROWN  
 100 NORTH ANKAS BLDG. #201  
 100 NORTH ANKAS BLDG. #201

**PROJECT CONTACT**  
 JEFFREY B. BROWN  
 100 NORTH ANKAS BLDG. #201  
 100 NORTH ANKAS BLDG. #201

**PROJECT CONTACT**  
 JEFFREY B. BROWN  
 100 NORTH ANKAS BLDG. #201  
 100 NORTH ANKAS BLDG. #201

**PROJECT CONTACT**  
 JEFFREY B. BROWN  
 100 NORTH ANKAS BLDG. #201  
 100 NORTH ANKAS BLDG. #201

**PROJECT CONTACT**  
 JEFFREY B. BROWN  
 100 NORTH ANKAS BLDG. #201  
 100 NORTH ANKAS BLDG. #201

**PROJECT CONTACT**  
 JEFFREY B. BROWN  
 100 NORTH ANKAS BLDG. #201  
 100 NORTH ANKAS BLDG. #201

**PROJECT CONTACT**  
 JEFFREY B. BROWN  
 100 NORTH ANKAS BLDG. #201  
 100 NORTH ANKAS BLDG. #201

**PROJECT CONTACT**  
 JEFFREY B. BROWN  
 100 NORTH ANKAS BLDG. #201  
 100 NORTH ANKAS BLDG. #201

**GENERAL NOTES**

1. DEMOLITION AND REPAIR CONTRACTOR TO VERIFY ALL WORK IS IN ACCORDANCE WITH ALL APPLICABLE CODES AND REGULATIONS.

**NEW WORK KETED NOTES**

1. REMOVE EXISTING EXTERIOR WALLS AND REPAIR AS SHOWN.
2. REMOVE EXISTING EXTERIOR WALLS AND REPAIR AS SHOWN.
3. REMOVE EXISTING EXTERIOR WALLS AND REPAIR AS SHOWN.
4. REMOVE EXISTING EXTERIOR WALLS AND REPAIR AS SHOWN.
5. REMOVE EXISTING EXTERIOR WALLS AND REPAIR AS SHOWN.
6. REMOVE EXISTING EXTERIOR WALLS AND REPAIR AS SHOWN.
7. REMOVE EXISTING EXTERIOR WALLS AND REPAIR AS SHOWN.
8. REMOVE EXISTING EXTERIOR WALLS AND REPAIR AS SHOWN.
9. REMOVE EXISTING EXTERIOR WALLS AND REPAIR AS SHOWN.
10. REMOVE EXISTING EXTERIOR WALLS AND REPAIR AS SHOWN.

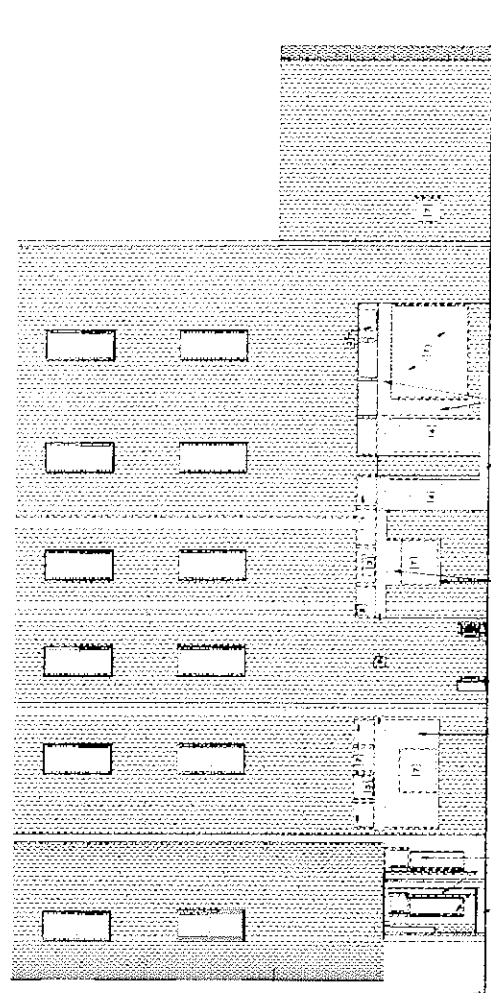

1. DEMOLITION ELEVATION EAST

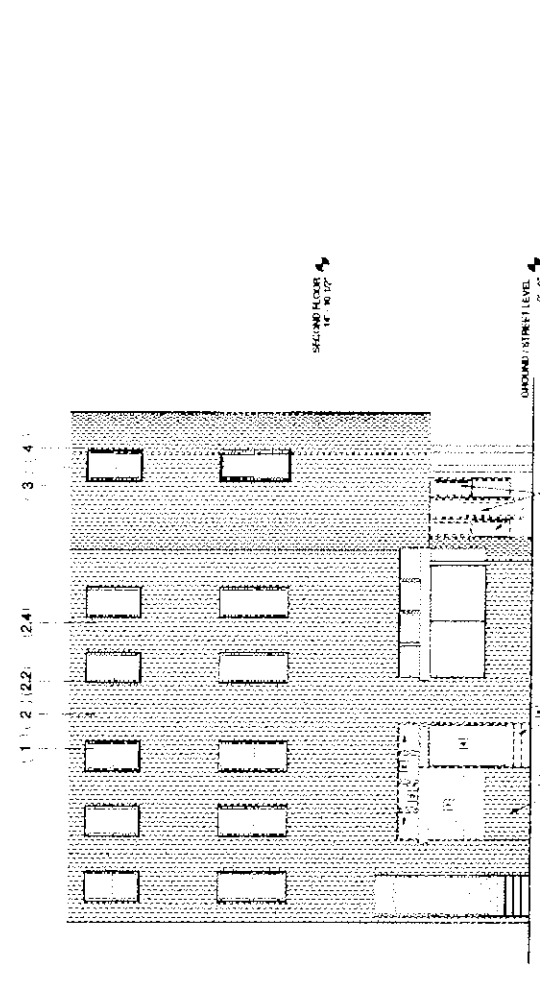

2. DEMOLITION ELEVATION SOUTH





THE BALDWIN GROUP  
1000 MARKET STREET  
COLUMBIA, SC 29201  
PH: 803.733.1111  
WWW.BALDWINGROUP.COM

OWNER/CLIENT  
FLEURS D'AVE BOUTIQUE  
1000 MARKET STREET  
COLUMBIA, SC 29201

STRUCTURAL CONSULTANT  
SARGENT & Lundy  
1000 MARKET STREET  
COLUMBIA, SC 29201

M&P CONSULTANT  
M&P CONSULTANTS INC.  
1000 MARKET STREET  
COLUMBIA, SC 29201

# FLEURS D'AVE BOUTIQUE INTERIOR TENANT IMPROVEMENT REFLECTED CEILING PLANS

PROJECT NO. 18-0278  
DATE 04/2018

REV. 1.00  
DATE 04/2018

NO.	DATE	DESCRIPTION
1.00	04/2018	ISSUED FOR PERMITS
1.01	04/2018	REVISIONS
1.02	04/2018	REVISIONS
1.03	04/2018	REVISIONS
1.04	04/2018	REVISIONS
1.05	04/2018	REVISIONS
1.06	04/2018	REVISIONS
1.07	04/2018	REVISIONS
1.08	04/2018	REVISIONS
1.09	04/2018	REVISIONS
1.10	04/2018	REVISIONS
1.11	04/2018	REVISIONS
1.12	04/2018	REVISIONS
1.13	04/2018	REVISIONS
1.14	04/2018	REVISIONS
1.15	04/2018	REVISIONS
1.16	04/2018	REVISIONS
1.17	04/2018	REVISIONS
1.18	04/2018	REVISIONS
1.19	04/2018	REVISIONS
1.20	04/2018	REVISIONS

PERMITS AND REGULATIONS  
THIS PROJECT IS SUBJECT TO THE PERMITS AND REGULATIONS OF THE CITY OF COLUMBIA, SOUTH CAROLINA. THE DESIGN SHALL BE SUBJECT TO THE PERMITS AND REGULATIONS OF THE CITY OF COLUMBIA, SOUTH CAROLINA.

## REFLECTED CEILING PLAN LEGEND

- SYMBOLS
- 1. REFLECTED CEILING
  - 2. REFLECTED CEILING WITH LIGHT FIXTURES
  - 3. REFLECTED CEILING WITH LIGHT FIXTURES AND ACCESSORIES
  - 4. REFLECTED CEILING WITH LIGHT FIXTURES AND ACCESSORIES AND ACCESSORIES
- NOTES
- 1. REFLECTED CEILING SHALL BE 10' X 10' SQUARE
  - 2. REFLECTED CEILING SHALL BE 10' X 10' SQUARE
  - 3. REFLECTED CEILING SHALL BE 10' X 10' SQUARE
  - 4. REFLECTED CEILING SHALL BE 10' X 10' SQUARE

## GENERAL NOTES

1. REFLECTED CEILING SHALL BE 10' X 10' SQUARE

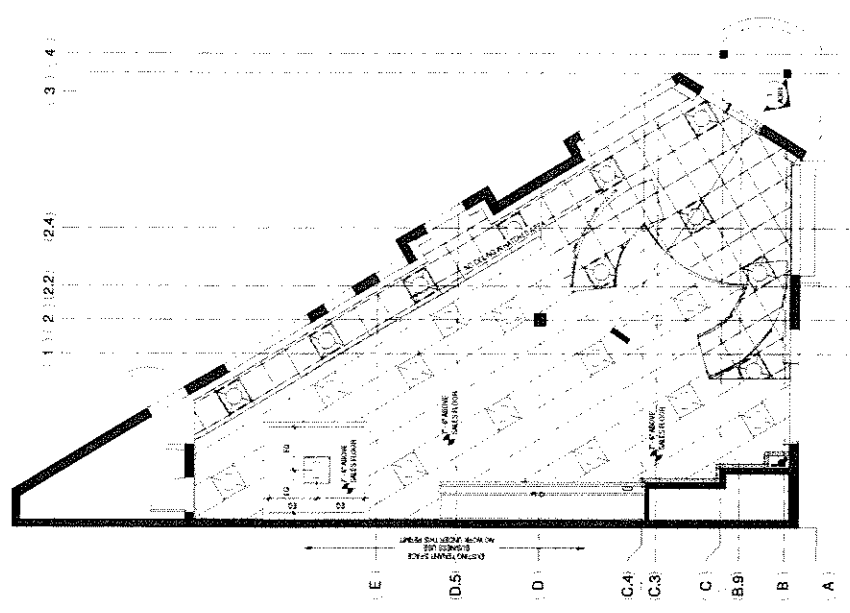
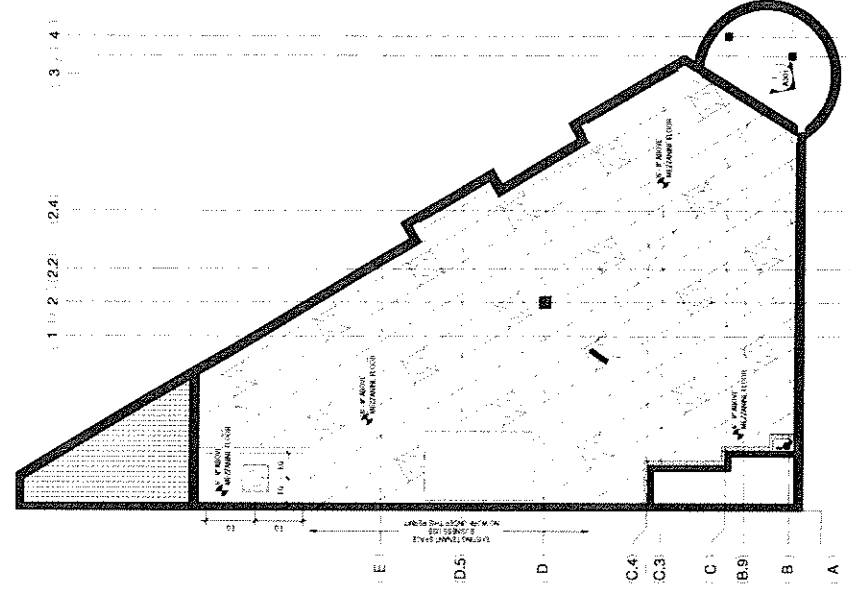

GROUND & SALES LEVELS - REFLECTED CEILING PLAN

MEZZANINE - REFLECTED CEILING PLAN

**EQUIPMENT PLAN LEGEND**

MARK	DESCRIPTION	MANUFACTURER & MODEL
E001	GRID TO CENTER	PROVIDED BY OWNER - COMMERCIAL CONTRACTOR/OWNER
E002	RECORDING MEDIUM	PROVIDED BY OWNER - COMMERCIAL CONTRACTOR/OWNER
E003	400' SHELLING	PROVIDED BY OWNER - COMMERCIAL CONTRACTOR/OWNER
E004	FINISH FLOOR	PROVIDED BY OWNER - COMMERCIAL CONTRACTOR/OWNER
E005	200' JAMES EARL RAY WALLS/STEEL WORK	PROVIDED BY OWNER - COMMERCIAL CONTRACTOR/OWNER
E006	400' MEZZANINE FLOOR/STAIRS	PROVIDED BY OWNER - COMMERCIAL CONTRACTOR/OWNER
E007	CONCRETE AREA CURB	PROVIDED BY OWNER - COMMERCIAL CONTRACTOR/OWNER
E008	CONCRETE AREA PAINT	PROVIDED BY OWNER - COMMERCIAL CONTRACTOR/OWNER
E009	GRADE CURB	PROVIDED BY OWNER - COMMERCIAL CONTRACTOR/OWNER
E010	SPRINKLER	PROVIDED BY OWNER - COMMERCIAL CONTRACTOR/OWNER



ARCHITECTS  
 1000 W. NORTH AVENUE, SUITE 2000  
 DENVER, CO 80202  
 TEL: 303.733.1111  
 WWW.EAGARCHITECTS.COM

OWNER/CLIENT  
 FLEURS D'AVE BOUTIQUE  
 1000 W. NORTH AVENUE, SUITE 2000  
 DENVER, CO 80202  
 TEL: 303.733.1111  
 WWW.FLEURSD'AVE.COM

MEP CONSULTANT  
 AIR CONSULTANTS, INC.  
 1000 W. NORTH AVENUE, SUITE 2000  
 DENVER, CO 80202  
 TEL: 303.733.1111  
 WWW.AIRCONSULTANTS.COM

FLEURS D'AVE BOUTIQUE  
 INTERIOR TENANT IMPROVEMENT  
 1000 W. NORTH AVENUE, SUITE 2000  
 DENVER, CO 80202  
 FINISHES, FURNISHINGS AND  
 EQUIPMENT PLANS & SCHEDULES

DATE	REVISION
10/15/2014	REV. 004
10/15/2014	REV. 003
10/15/2014	REV. 002
10/15/2014	REV. 001

THIS DOCUMENT IS THE PROPERTY OF EAG ARCHITECTS AND IS TO BE USED ONLY FOR THE PROJECT AND SITE SPECIFICALLY IDENTIFIED HEREIN. IT IS NOT TO BE REPRODUCED, COPIED, OR TRANSMITTED IN ANY FORM OR BY ANY MEANS, ELECTRONIC OR MECHANICAL, INCLUDING PHOTOCOPYING, RECORDING, OR BY ANY INFORMATION STORAGE AND RETRIEVAL SYSTEM, WITHOUT THE WRITTEN PERMISSION OF EAG ARCHITECTS.

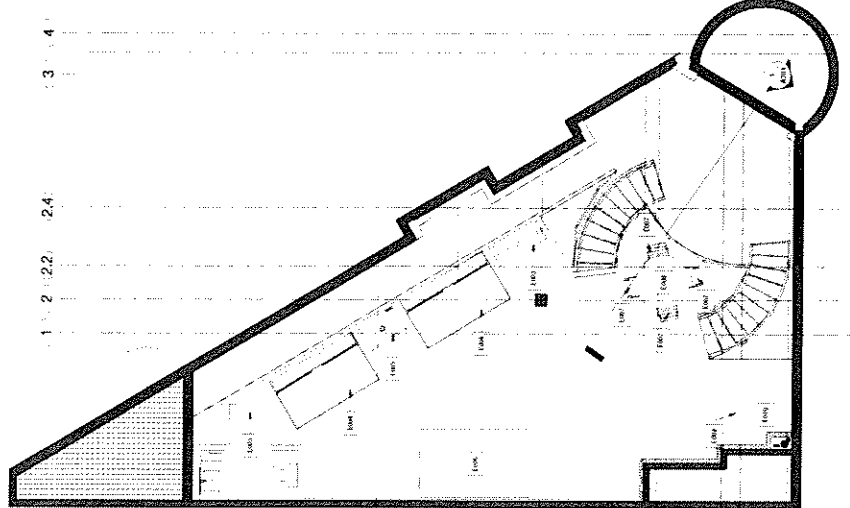

2. MEZZANINE LEVEL - EQUIPMENT

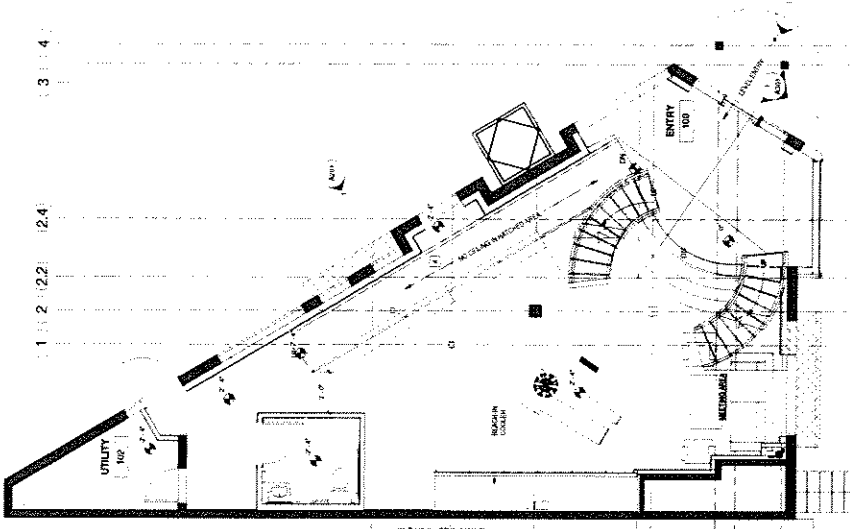

1. GROUND (STREET) FLOOR PLAN - EQUIPMENT

**B&B**  
ARCHITECTS

700 PARKSIDE INDUSTRIAL CENTER  
COLUMBIA, MD 21046  
PH: 410-278-0000  
WWW.BANDBARCHITECTS.COM

**OWNER/CLIENT**  
FLEURS DAVE BOUTIQUE  
1206 W NORTHMINNE BAYMOSE, MD 21217  
DAVID PEREZ  
410-278-0000

**STRUCTURAL CONSULTANT**  
SHAWK AND ASSOCIATES, INC.  
1000 WASHINGTON BLVD, SUITE 100  
COLUMBIA, MD 21046  
410-278-0000

**MSP CONSULTANT**  
JAY CONSTRUCTION, INC.  
1000 WASHINGTON BLVD, SUITE 100  
COLUMBIA, MD 21046  
410-278-0000

**FLEURS DAVE BOUTIQUE**  
INTERIOR TENANT IMPROVEMENT  
EXTERIOR ELEVATIONS - NEW WORK  
1206 W NORTHMINNE BAYMOSE, MD 21217

PROJECT NO. 18-030M  
DATE: 04/20/24

NO.	REVISION	DATE
1	ISSUE	04/20/24
2	PERMITS	04/20/24
3	FOR PERMITTING	04/20/24

**DISCLAIMER:** THESE ELEVATIONS ARE PRELIMINARY AND NOT FOR CONSTRUCTION. ANY CHANGES TO THE DESIGN SHALL BE MADE THROUGH THE ARCHITECT'S WRITTEN PERMISSION. THE ARCHITECT IS NOT RESPONSIBLE FOR THE ACCURACY OF ANY INFORMATION PROVIDED BY OTHER PROFESSIONALS OR THE STATE OF MARYLAND.

**LICENSING:** ARCHITECT  
L. PEREZ  
L. PEREZ  
L. PEREZ

A201

**GENERAL NOTES**

1. DIMENSIONS ARE SHOWN IN PLACE UNLESS OTHERWISE NOTED.

**NEW WORK KEYED NOTES**

1. NEW STOREFRONT WINDOW: REFER TO PLAN FOR ADDITIONAL INFORMATION.

2. MATCH TO EXISTING WINDOW FRAME.

3. MATCH TO EXISTING WINDOW FRAME.

4. MATCH TO EXISTING WINDOW FRAME.

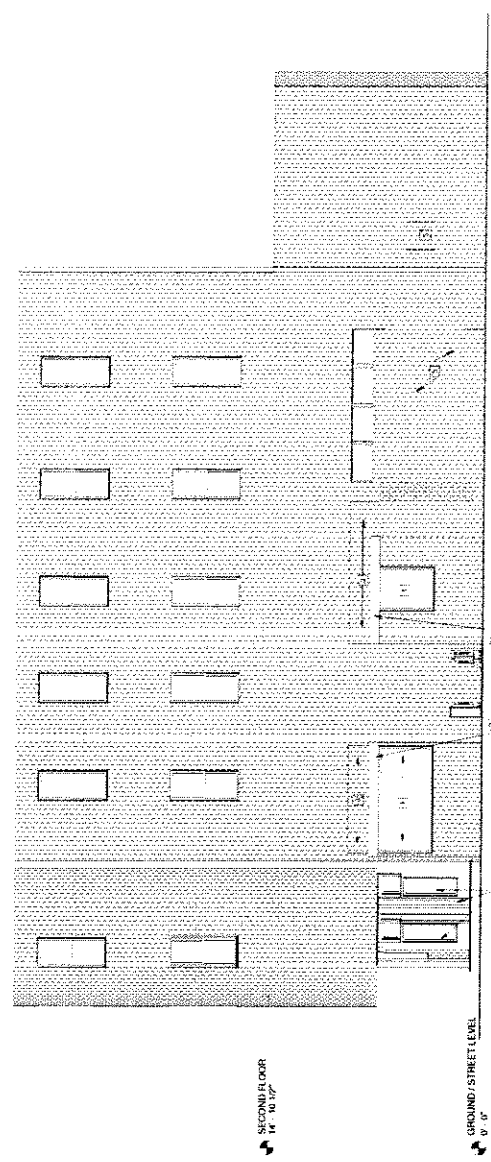

1. EAST ELEVATION - NEW WORK

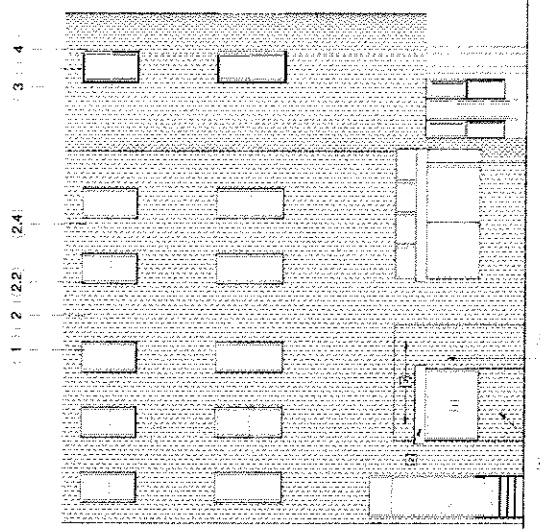

2. SOUTH ELEVATION - NEW WORK



200 HANCOCK STREET, SUITE 200  
BALTIMORE, MD 21201  
PH: 410.528.1234 FAX: 410.528.1235  
WWW.ESANDS.COM

**OWNER/CLIENT**  
FLEURS D'AVE BOUTIQUE  
100 W. NORTH AVENUE, BALTIMORE, MD 21201  
TEL: 410.528.1234

**STRUCTURAL CONSULTANT**  
BIRDA AND ASSOCIATES, INC.  
100 W. NORTH AVENUE, SUITE 200  
BALTIMORE, MD 21201  
TEL: 410.528.1234

**MEP CONSULTANT**  
JAP CONSULTANTS, INC.  
100 W. NORTH AVENUE, SUITE 200  
BALTIMORE, MD 21201  
TEL: 410.528.1234

**MEP CONSULTANT**  
JAP CONSULTANTS, INC.  
100 W. NORTH AVENUE, SUITE 200  
BALTIMORE, MD 21201  
TEL: 410.528.1234

# FLEURS D'AVE BOUTIQUE INTERIOR TENANT IMPROVEMENT 100 W. NORTH AVENUE, BALTIMORE, MD 21201 INTERIOR SECTIONS

DATE	10/20/14
PROJECT	PH-150
SCALE	1/8" = 1'-0"

REV	NO.	DATE	DESCRIPTION

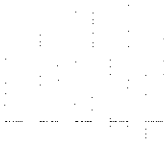

THIS DOCUMENT IS THE PROPERTY OF ES&S ARCHITECTS. IT IS TO BE USED ONLY FOR THE PROJECT AND SITE SPECIFICALLY IDENTIFIED HEREIN. IT IS NOT TO BE REPRODUCED, COPIED, OR TRANSMITTED IN ANY FORM OR BY ANY MEANS, ELECTRONIC OR MECHANICAL, INCLUDING PHOTOCOPYING, RECORDING, OR BY ANY INFORMATION STORAGE AND RETRIEVAL SYSTEM, WITHOUT THE WRITTEN PERMISSION OF ES&S ARCHITECTS.

LEONARD E. SHAW  
REGISTERED PROFESSIONAL ARCHITECT  
STATE OF MARYLAND  
LICENSE NO. 14017  
EXPIRES 12/31/2015

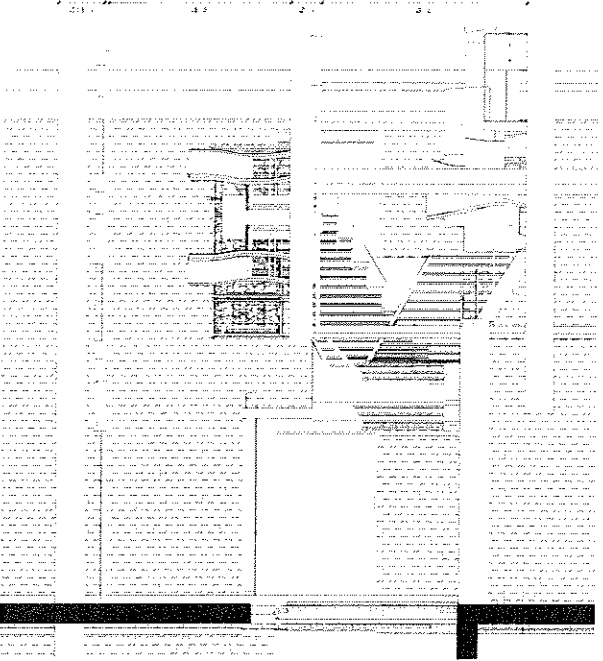

SECTION @ ENTRY

- SECOND FLOOR 14' - 10 1/2"
- MEZZANINE 6' - 4"
- GROUND LEVEL 0"
- SALES FLOOR 2' - 4"
- BASEMENT 5' - 0"

**OWNER:** CLIENT  
 FLEURS D'AVE BOULIERS  
 BALTIMORE, MD 21201  
**OWNER'S ARCHITECT:**  
 FLEURS D'AVE BOULIERS  
 1300 N. CALVERT STREET  
 BALTIMORE, MD 21201  
**ARCHITECT:** B&B ARCHITECTS  
 1300 N. CALVERT STREET  
 BALTIMORE, MD 21201  
**DATE:** 12/20/2013

**MEP CONSULTANT:**  
 JPC CONSULTANTS, INC.  
 100 W. NORTH AVENUE, SUITE 300  
 BALTIMORE, MD 21201  
 TEL: 410-524-7500  
 FAX: 410-524-7501  
 WWW.JPCCONSULTANTS.COM

**FLEURS D'AVE BOULIERS**  
**INTERIOR TENANT IMPROVEMENT**  
**ENLARGED RESTROOM PLANS AND ELEVATIONS**

**PROJECT NO.:** 13-0224  
**DATE:** 12/20/13  
**REV:** 01  
**DESCRIPTION:** MEZZANINE, TOILET WALL, SINK WALL, GRAB BAR WALL, RESTROOM

**PROFESSIONAL SEAL:**  
 JAMES P. CHAMBERS, PE  
 LICENSE NO. 14214  
 STATE OF MARYLAND  
**DATE:** 12/20/13

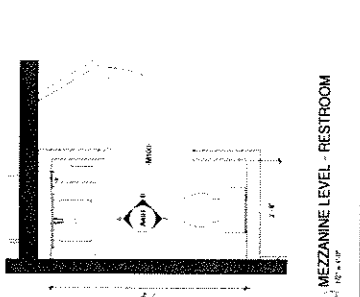
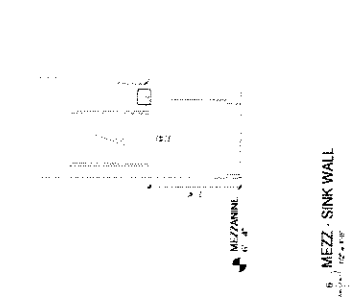
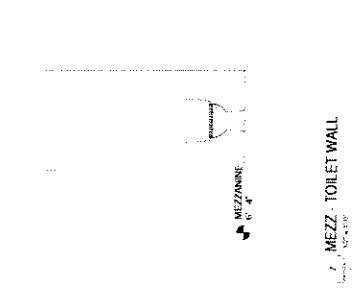
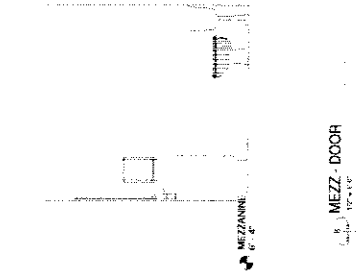
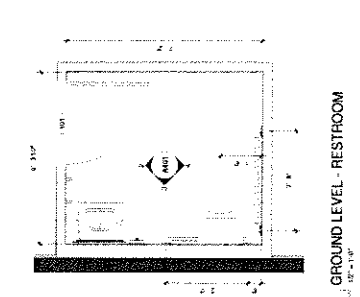
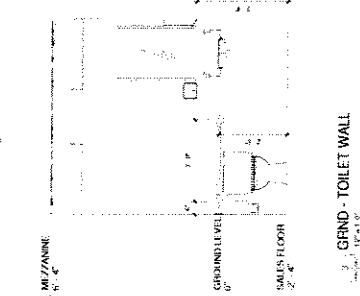
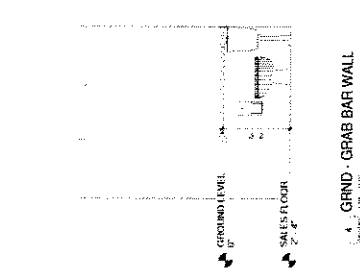

**TOILET ROOM ACCESSORY SCHEDULE**

MODEL	DESCRIPTION	MANUFACTURER
1	TOILET PAPER DISPENSER	BRONCK
2	TOILET BRUSH	BRONCK
3	TOILET SEAT	BRONCK
4	TOILET BRUSH HOLDER	BRONCK

**FINISH SCHEDULE**

FLOORING	DESCRIPTION
FC1	CONCRETE
FC2	CONCRETE
FC3	CONCRETE
FC4	CONCRETE
FC5	CONCRETE
FC6	CONCRETE
FC7	CONCRETE
FC8	CONCRETE
FC9	CONCRETE
FC10	CONCRETE
FC11	CONCRETE
FC12	CONCRETE
FC13	CONCRETE
FC14	CONCRETE
FC15	CONCRETE
FC16	CONCRETE
FC17	CONCRETE
FC18	CONCRETE
FC19	CONCRETE
FC20	CONCRETE
FC21	CONCRETE
FC22	CONCRETE
FC23	CONCRETE
FC24	CONCRETE
FC25	CONCRETE
FC26	CONCRETE
FC27	CONCRETE
FC28	CONCRETE
FC29	CONCRETE
FC30	CONCRETE
FC31	CONCRETE
FC32	CONCRETE
FC33	CONCRETE
FC34	CONCRETE
FC35	CONCRETE
FC36	CONCRETE
FC37	CONCRETE
FC38	CONCRETE
FC39	CONCRETE
FC40	CONCRETE
FC41	CONCRETE
FC42	CONCRETE
FC43	CONCRETE
FC44	CONCRETE
FC45	CONCRETE
FC46	CONCRETE
FC47	CONCRETE
FC48	CONCRETE
FC49	CONCRETE
FC50	CONCRETE
FC51	CONCRETE
FC52	CONCRETE
FC53	CONCRETE
FC54	CONCRETE
FC55	CONCRETE
FC56	CONCRETE
FC57	CONCRETE
FC58	CONCRETE
FC59	CONCRETE
FC60	CONCRETE
FC61	CONCRETE
FC62	CONCRETE
FC63	CONCRETE
FC64	CONCRETE
FC65	CONCRETE
FC66	CONCRETE
FC67	CONCRETE
FC68	CONCRETE
FC69	CONCRETE
FC70	CONCRETE
FC71	CONCRETE
FC72	CONCRETE
FC73	CONCRETE
FC74	CONCRETE
FC75	CONCRETE
FC76	CONCRETE
FC77	CONCRETE
FC78	CONCRETE
FC79	CONCRETE
FC80	CONCRETE
FC81	CONCRETE
FC82	CONCRETE
FC83	CONCRETE
FC84	CONCRETE
FC85	CONCRETE
FC86	CONCRETE
FC87	CONCRETE
FC88	CONCRETE
FC89	CONCRETE
FC90	CONCRETE
FC91	CONCRETE
FC92	CONCRETE
FC93	CONCRETE
FC94	CONCRETE
FC95	CONCRETE
FC96	CONCRETE
FC97	CONCRETE
FC98	CONCRETE
FC99	CONCRETE
FC100	CONCRETE

**CEILING**

C1	CONCRETE
C2	CONCRETE
C3	CONCRETE
C4	CONCRETE
C5	CONCRETE
C6	CONCRETE
C7	CONCRETE
C8	CONCRETE
C9	CONCRETE
C10	CONCRETE
C11	CONCRETE
C12	CONCRETE
C13	CONCRETE
C14	CONCRETE
C15	CONCRETE
C16	CONCRETE
C17	CONCRETE
C18	CONCRETE
C19	CONCRETE
C20	CONCRETE
C21	CONCRETE
C22	CONCRETE
C23	CONCRETE
C24	CONCRETE
C25	CONCRETE
C26	CONCRETE
C27	CONCRETE
C28	CONCRETE
C29	CONCRETE
C30	CONCRETE
C31	CONCRETE
C32	CONCRETE
C33	CONCRETE
C34	CONCRETE
C35	CONCRETE
C36	CONCRETE
C37	CONCRETE
C38	CONCRETE
C39	CONCRETE
C40	CONCRETE
C41	CONCRETE
C42	CONCRETE
C43	CONCRETE
C44	CONCRETE
C45	CONCRETE
C46	CONCRETE
C47	CONCRETE
C48	CONCRETE
C49	CONCRETE
C50	CONCRETE
C51	CONCRETE
C52	CONCRETE
C53	CONCRETE
C54	CONCRETE
C55	CONCRETE
C56	CONCRETE
C57	CONCRETE
C58	CONCRETE
C59	CONCRETE
C60	CONCRETE
C61	CONCRETE
C62	CONCRETE
C63	CONCRETE
C64	CONCRETE
C65	CONCRETE
C66	CONCRETE
C67	CONCRETE
C68	CONCRETE
C69	CONCRETE
C70	CONCRETE
C71	CONCRETE
C72	CONCRETE
C73	CONCRETE
C74	CONCRETE
C75	CONCRETE
C76	CONCRETE
C77	CONCRETE
C78	CONCRETE
C79	CONCRETE
C80	CONCRETE
C81	CONCRETE
C82	CONCRETE
C83	CONCRETE
C84	CONCRETE
C85	CONCRETE
C86	CONCRETE
C87	CONCRETE
C88	CONCRETE
C89	CONCRETE
C90	CONCRETE
C91	CONCRETE
C92	CONCRETE
C93	CONCRETE
C94	CONCRETE
C95	CONCRETE
C96	CONCRETE
C97	CONCRETE
C98	CONCRETE
C99	CONCRETE
C100	CONCRETE

**GENERAL NOTES**

1. VERIFY ALL DIMENSIONS WITH ARCHITECT AND OWNER. BE RESPONSIBLE FOR WALL BEHAVIOR. VERIFY INTERCLOCKER.
2. VERIFY ALL DIMENSIONS WITH ARCHITECT AND OWNER. BE RESPONSIBLE FOR WALL BEHAVIOR. VERIFY INTERCLOCKER.
3. VERIFY ALL DIMENSIONS WITH ARCHITECT AND OWNER. BE RESPONSIBLE FOR WALL BEHAVIOR. VERIFY INTERCLOCKER.
4. VERIFY ALL DIMENSIONS WITH ARCHITECT AND OWNER. BE RESPONSIBLE FOR WALL BEHAVIOR. VERIFY INTERCLOCKER.
5. VERIFY ALL DIMENSIONS WITH ARCHITECT AND OWNER. BE RESPONSIBLE FOR WALL BEHAVIOR. VERIFY INTERCLOCKER.

INTERIOR FINISH GENERAL NOTES  
 1. VERIFY ALL DIMENSIONS WITH ARCHITECT AND OWNER. BE RESPONSIBLE FOR WALL BEHAVIOR. VERIFY INTERCLOCKER.  
 2. VERIFY ALL DIMENSIONS WITH ARCHITECT AND OWNER. BE RESPONSIBLE FOR WALL BEHAVIOR. VERIFY INTERCLOCKER.  
 3. VERIFY ALL DIMENSIONS WITH ARCHITECT AND OWNER. BE RESPONSIBLE FOR WALL BEHAVIOR. VERIFY INTERCLOCKER.  
 4. VERIFY ALL DIMENSIONS WITH ARCHITECT AND OWNER. BE RESPONSIBLE FOR WALL BEHAVIOR. VERIFY INTERCLOCKER.  
 5. VERIFY ALL DIMENSIONS WITH ARCHITECT AND OWNER. BE RESPONSIBLE FOR WALL BEHAVIOR. VERIFY INTERCLOCKER.  
 6. VERIFY ALL DIMENSIONS WITH ARCHITECT AND OWNER. BE RESPONSIBLE FOR WALL BEHAVIOR. VERIFY INTERCLOCKER.  
 7. VERIFY ALL DIMENSIONS WITH ARCHITECT AND OWNER. BE RESPONSIBLE FOR WALL BEHAVIOR. VERIFY INTERCLOCKER.  
 8. VERIFY ALL DIMENSIONS WITH ARCHITECT AND OWNER. BE RESPONSIBLE FOR WALL BEHAVIOR. VERIFY INTERCLOCKER.  
 9. VERIFY ALL DIMENSIONS WITH ARCHITECT AND OWNER. BE RESPONSIBLE FOR WALL BEHAVIOR. VERIFY INTERCLOCKER.  
 10. VERIFY ALL DIMENSIONS WITH ARCHITECT AND OWNER. BE RESPONSIBLE FOR WALL BEHAVIOR. VERIFY INTERCLOCKER.

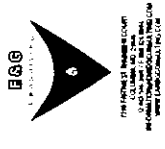

**F&S CONSULTANTS, INC.**  
 1700 NORTH AVENUE, SUITE 200  
 FORT WORTH, TEXAS 76102  
 TEL: 817.339.1111  
 FAX: 817.339.1112  
 WWW.F&SCONSULTANTS.COM

**FLEURS D'AVE BOUTIQUE**  
 INTERIOR TENANT IMPROVEMENT  
 1200 W. NORTHAVENUE, SUITE 2000  
 STAIR PLANS, SECTIONS AND DETAILS

DATE: 10/20/10  
 PROJECT: FLEURS D'AVE BOUTIQUE  
 SHEET: STAIR PLANS, SECTIONS AND DETAILS

NO.	DESCRIPTION	DATE
1	ISSUED FOR PERMIT	10/20/10
2	ISSUED FOR CONSTRUCTION	11/15/10
3	ISSUED FOR CORRECTIONS	12/15/10
4	ISSUED FOR CORRECTIONS	01/15/11
5	ISSUED FOR CORRECTIONS	02/15/11
6	ISSUED FOR CORRECTIONS	03/15/11
7	ISSUED FOR CORRECTIONS	04/15/11
8	ISSUED FOR CORRECTIONS	05/15/11
9	ISSUED FOR CORRECTIONS	06/15/11
10	ISSUED FOR CORRECTIONS	07/15/11
11	ISSUED FOR CORRECTIONS	08/15/11
12	ISSUED FOR CORRECTIONS	09/15/11
13	ISSUED FOR CORRECTIONS	10/15/11
14	ISSUED FOR CORRECTIONS	11/15/11
15	ISSUED FOR CORRECTIONS	12/15/11
16	ISSUED FOR CORRECTIONS	01/15/12
17	ISSUED FOR CORRECTIONS	02/15/12
18	ISSUED FOR CORRECTIONS	03/15/12
19	ISSUED FOR CORRECTIONS	04/15/12
20	ISSUED FOR CORRECTIONS	05/15/12
21	ISSUED FOR CORRECTIONS	06/15/12
22	ISSUED FOR CORRECTIONS	07/15/12
23	ISSUED FOR CORRECTIONS	08/15/12
24	ISSUED FOR CORRECTIONS	09/15/12
25	ISSUED FOR CORRECTIONS	10/15/12
26	ISSUED FOR CORRECTIONS	11/15/12
27	ISSUED FOR CORRECTIONS	12/15/12
28	ISSUED FOR CORRECTIONS	01/15/13
29	ISSUED FOR CORRECTIONS	02/15/13
30	ISSUED FOR CORRECTIONS	03/15/13
31	ISSUED FOR CORRECTIONS	04/15/13
32	ISSUED FOR CORRECTIONS	05/15/13
33	ISSUED FOR CORRECTIONS	06/15/13
34	ISSUED FOR CORRECTIONS	07/15/13
35	ISSUED FOR CORRECTIONS	08/15/13
36	ISSUED FOR CORRECTIONS	09/15/13
37	ISSUED FOR CORRECTIONS	10/15/13
38	ISSUED FOR CORRECTIONS	11/15/13
39	ISSUED FOR CORRECTIONS	12/15/13
40	ISSUED FOR CORRECTIONS	01/15/14
41	ISSUED FOR CORRECTIONS	02/15/14
42	ISSUED FOR CORRECTIONS	03/15/14
43	ISSUED FOR CORRECTIONS	04/15/14
44	ISSUED FOR CORRECTIONS	05/15/14
45	ISSUED FOR CORRECTIONS	06/15/14
46	ISSUED FOR CORRECTIONS	07/15/14
47	ISSUED FOR CORRECTIONS	08/15/14
48	ISSUED FOR CORRECTIONS	09/15/14
49	ISSUED FOR CORRECTIONS	10/15/14
50	ISSUED FOR CORRECTIONS	11/15/14
51	ISSUED FOR CORRECTIONS	12/15/14
52	ISSUED FOR CORRECTIONS	01/15/15
53	ISSUED FOR CORRECTIONS	02/15/15
54	ISSUED FOR CORRECTIONS	03/15/15
55	ISSUED FOR CORRECTIONS	04/15/15
56	ISSUED FOR CORRECTIONS	05/15/15
57	ISSUED FOR CORRECTIONS	06/15/15
58	ISSUED FOR CORRECTIONS	07/15/15
59	ISSUED FOR CORRECTIONS	08/15/15
60	ISSUED FOR CORRECTIONS	09/15/15
61	ISSUED FOR CORRECTIONS	10/15/15
62	ISSUED FOR CORRECTIONS	11/15/15
63	ISSUED FOR CORRECTIONS	12/15/15
64	ISSUED FOR CORRECTIONS	01/15/16
65	ISSUED FOR CORRECTIONS	02/15/16
66	ISSUED FOR CORRECTIONS	03/15/16
67	ISSUED FOR CORRECTIONS	04/15/16
68	ISSUED FOR CORRECTIONS	05/15/16
69	ISSUED FOR CORRECTIONS	06/15/16
70	ISSUED FOR CORRECTIONS	07/15/16
71	ISSUED FOR CORRECTIONS	08/15/16
72	ISSUED FOR CORRECTIONS	09/15/16
73	ISSUED FOR CORRECTIONS	10/15/16
74	ISSUED FOR CORRECTIONS	11/15/16
75	ISSUED FOR CORRECTIONS	12/15/16
76	ISSUED FOR CORRECTIONS	01/15/17
77	ISSUED FOR CORRECTIONS	02/15/17
78	ISSUED FOR CORRECTIONS	03/15/17
79	ISSUED FOR CORRECTIONS	04/15/17
80	ISSUED FOR CORRECTIONS	05/15/17
81	ISSUED FOR CORRECTIONS	06/15/17
82	ISSUED FOR CORRECTIONS	07/15/17
83	ISSUED FOR CORRECTIONS	08/15/17
84	ISSUED FOR CORRECTIONS	09/15/17
85	ISSUED FOR CORRECTIONS	10/15/17
86	ISSUED FOR CORRECTIONS	11/15/17
87	ISSUED FOR CORRECTIONS	12/15/17
88	ISSUED FOR CORRECTIONS	01/15/18
89	ISSUED FOR CORRECTIONS	02/15/18
90	ISSUED FOR CORRECTIONS	03/15/18
91	ISSUED FOR CORRECTIONS	04/15/18
92	ISSUED FOR CORRECTIONS	05/15/18
93	ISSUED FOR CORRECTIONS	06/15/18
94	ISSUED FOR CORRECTIONS	07/15/18
95	ISSUED FOR CORRECTIONS	08/15/18
96	ISSUED FOR CORRECTIONS	09/15/18
97	ISSUED FOR CORRECTIONS	10/15/18
98	ISSUED FOR CORRECTIONS	11/15/18
99	ISSUED FOR CORRECTIONS	12/15/18
100	ISSUED FOR CORRECTIONS	01/15/19

**A402**

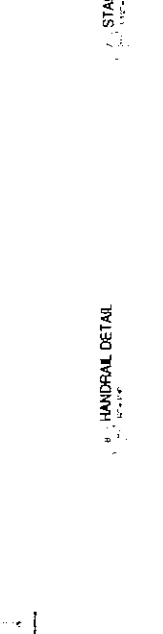
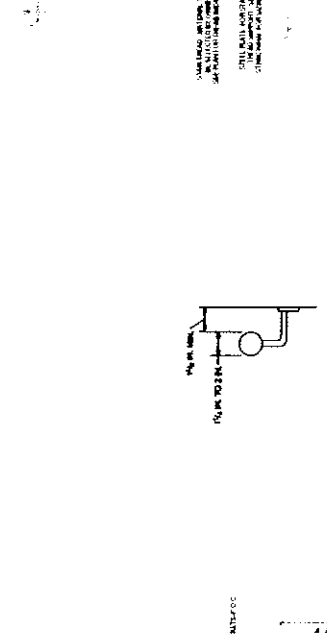
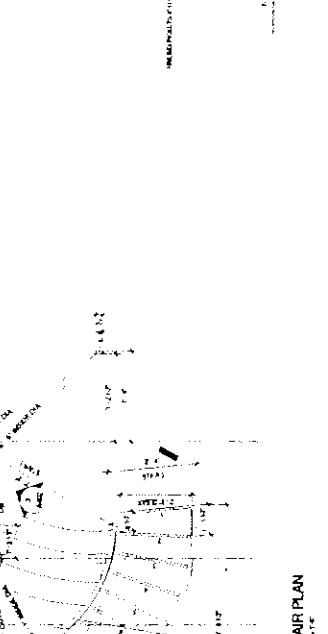
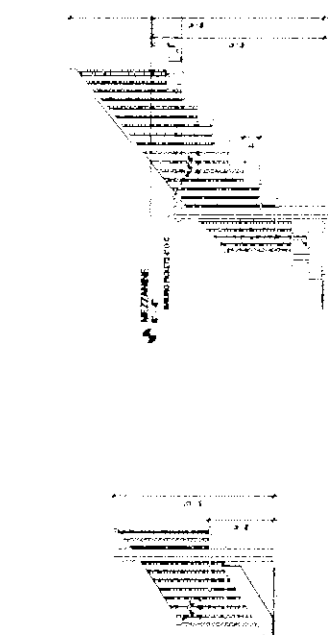
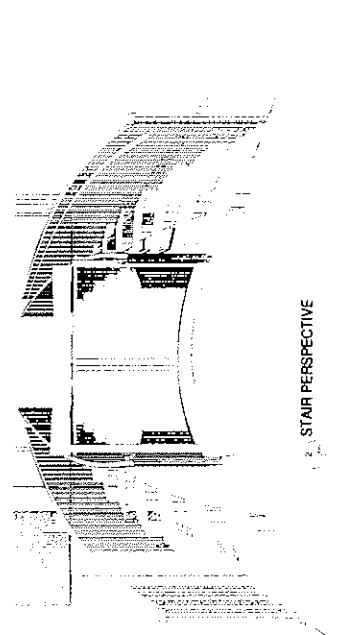

OWNER: CLIENT  
 PROJECT: FLEURS D'AVE BOUTIQUE  
 ARCHITECT: F&S CONSULTANTS, INC.  
 STRUCTURAL CONSULTANT: STRUCTURAL CONSULTANTS, INC.  
 MECHANICAL CONSULTANT: MECHANICAL CONSULTANTS, INC.  
 ELECTRICAL CONSULTANT: ELECTRICAL CONSULTANTS, INC.  
 PLUMBING CONSULTANT: PLUMBING CONSULTANTS, INC.  
 FIRE PROTECTION CONSULTANT: FIRE PROTECTION CONSULTANTS, INC.  
 ELEVATOR CONSULTANT: ELEVATOR CONSULTANTS, INC.  
 ENVIRONMENTAL CONSULTANT: ENVIRONMENTAL CONSULTANTS, INC.  
 HISTORIC PRESERVATION CONSULTANT: HISTORIC PRESERVATION CONSULTANTS, INC.  
 LANDSCAPE ARCHITECT: LANDSCAPE ARCHITECTS, INC.  
 INTERIOR DESIGNER: INTERIOR DESIGNERS, INC.  
 SIGNAGE CONSULTANT: SIGNAGE CONSULTANTS, INC.  
 SPECIALTY CONTRACTOR: SPECIALTY CONTRACTORS, INC.  
 GENERAL CONTRACTOR: GENERAL CONTRACTORS, INC.

DATE: 10/20/10  
 PROJECT: FLEURS D'AVE BOUTIQUE  
 SHEET: STAIR PLANS, SECTIONS AND DETAILS

DATE: 10/20/10  
 PROJECT: FLEURS D'AVE BOUTIQUE  
 SHEET: STAIR PLANS, SECTIONS AND DETAILS

DATE: 10/20/10  
 PROJECT: FLEURS D'AVE BOUTIQUE  
 SHEET: STAIR PLANS, SECTIONS AND DETAILS





ES&G ARCHITECTS  
 718 PATRICK STREET  
 COLUMBIA, MD 21046  
 410.730.1000  
 WWW.ESANDGARCHITECTS.COM

OWNER/CLIENT  
 FLEURS DAVE BOUTIQUE

STRUCTURAL CONSULTANT  
 SHARON AND ASSOCIATES, INC.  
 1000 W. PATRICK STREET  
 COLUMBIA, MD 21046  
 410.730.1000  
 WWW.SHARONANDASSOCIATES.COM

MEP CONSULTANT  
 JAP CONSULTANTS, INC.  
 1000 W. PATRICK STREET  
 COLUMBIA, MD 21046  
 410.730.1000  
 WWW.JAPCONSULTANTS.COM

FLEURS DAVE BOUTIQUE  
 INTERIOR TENANT IMPROVEMENT  
 FOR BRANDON

DATE: 05.2024  
 SHEET: 01 OF 05  
 PROJECT: FLEURS DAVE BOUTIQUE

SCALE: AS SHOWN  
 DRAWN BY: [Name]  
 CHECKED BY: [Name]

THIS DOCUMENT IS THE PROPERTY OF ES&G ARCHITECTS. IT IS TO BE USED ONLY FOR THE PROJECT AND SITE SPECIFICALLY IDENTIFIED HEREON. IT IS NOT TO BE REPRODUCED, COPIED, OR TRANSMITTED IN ANY FORM OR BY ANY MEANS, WITHOUT THE WRITTEN PERMISSION OF ES&G ARCHITECTS.

A403

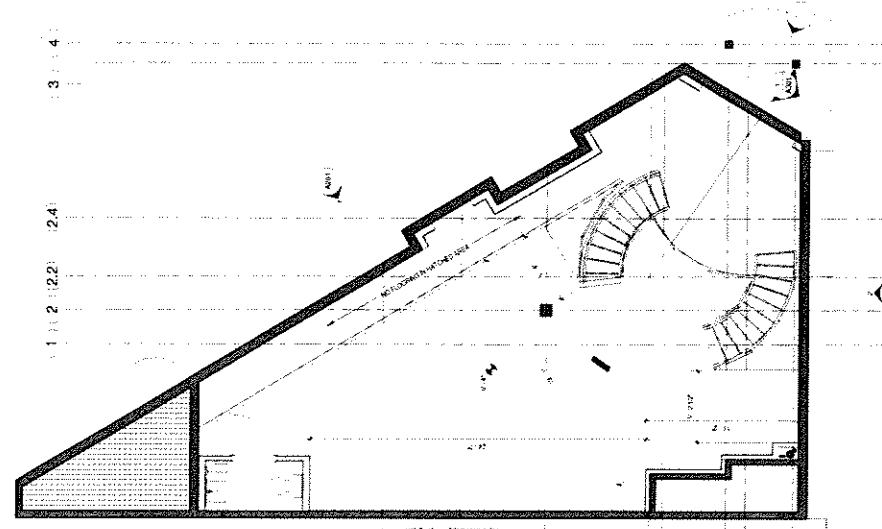

MEZZANINE LEVEL - NEW - BRANDON

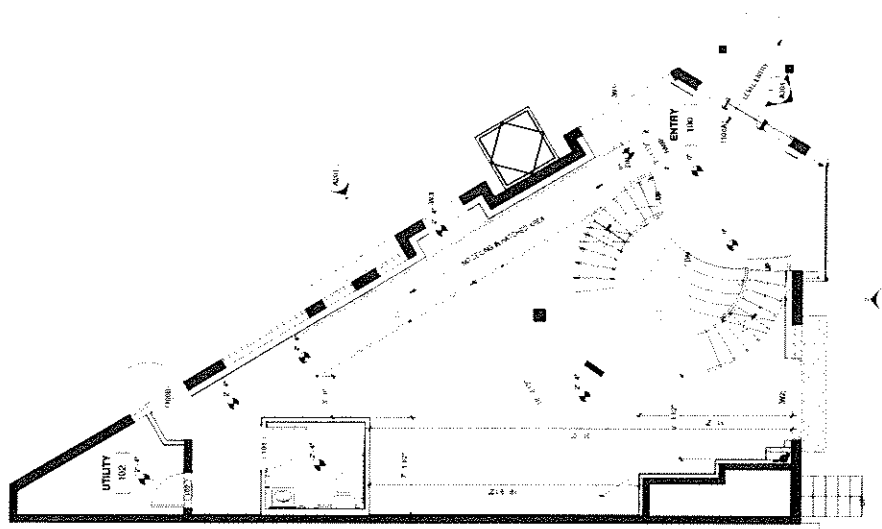

GROUND (STREET) FLOOR PLAN - NEW WORK

MARK	Width	Height	Type	Thickness	Material	Finish	Frame Type	Joint	Head	Frame Material	Comments
101	3'-0"	7'-0"	WOOD	1 1/2"	WOOD	WOOD	WOOD	J1 (WOOD)	J1 (WOOD)	WOOD	FRONT OF DOOR / DOUBLE HUNG WINDOW
102	3'-0"	7'-0"	WOOD	1 1/2"	WOOD	WOOD	WOOD	J2 (WOOD)	J2 (WOOD)	WOOD	FRONT OF DOOR / DOUBLE HUNG WINDOW

- GENERAL NOTES:**
1. REFER TO ARCHITECTURAL DRAWINGS FOR WINDOW SCHEDULES AND FINISHES.
  2. REFER TO ARCHITECTURAL DRAWINGS FOR WINDOW SCHEDULES AND FINISHES.
  3. PROVIDE SCHEDULES FOR COMPLETE INSTALLATION AND FUNCTION OF WINDOW.
  4. REFER TO ARCHITECTURAL DRAWINGS FOR WINDOW SCHEDULES AND FINISHES.
  5. REFER TO ARCHITECTURAL DRAWINGS FOR WINDOW SCHEDULES AND FINISHES.

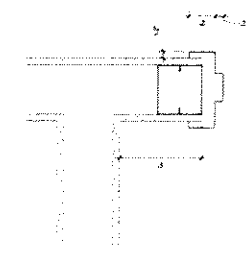

**DOOR HEADJAMB DETAIL**  
 1'-0" x 7'-0"

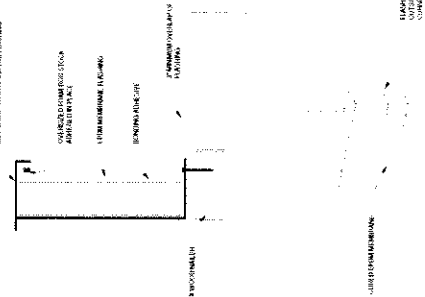

**ROOF CURB DETAIL**  
 1'-0" x 7'-0"

- LEGEND:**
- 1. METAL CLIP ON WINDOW HEADJAMB
  - 2. CORRUGATED POLYMER SHEET (16 GA. GALVALUME)
  - 3. 2x4 STUDS (SPACED @ 24\"/>

**UL FLOOR DESIGN - G201**  
 1'-0" x 7'-0"

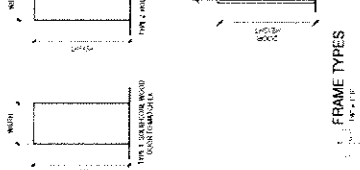

**FRAME TYPES**  
 1'-0" x 7'-0"

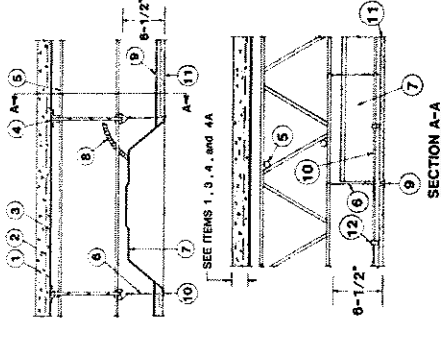

- LEGEND:**
- 1. METAL CLIP ON WINDOW HEADJAMB
  - 2. CORRUGATED POLYMER SHEET (16 GA. GALVALUME)
  - 3. 2x4 STUDS (SPACED @ 24\"/>

**UL FLOOR DESIGN - G201**  
 1'-0" x 7'-0"

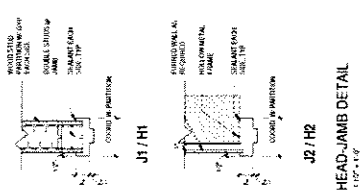

**HEAD-JAMB DETAIL**  
 1'-0" x 7'-0"

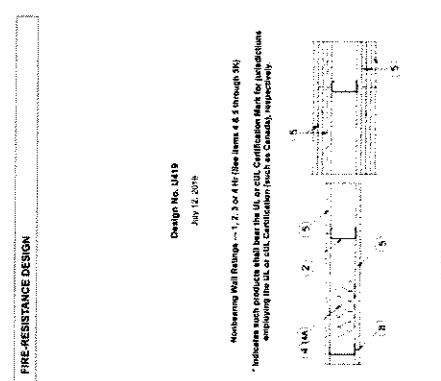

- LEGEND:**
- 1. 2x4 STUDS (SPACED @ 24\"/>

**UL WALL DESIGN - U419**  
 1'-0" x 7'-0"

**ORNER/CIENT**

**STRUCTURAL CONSULTANT**

**HSP CONSULTANT**

**FLURS DAVE BOUTIQUE**

**INTERIOR TENANT IMPROVEMENT**

**SCHEDULES & DETAILS**

**UL WALL DESIGN - U419**

**UL FLOOR DESIGN - G201**

**UL HEADJAMB DETAIL - U419**

ARCHITECT



BBG ARCHITECTS  
1200 AVENUE J  
MOUNTAIN VIEW, MD 20896  
PH: 301.556.0000 FAX: 301.556.0001  
WWW.BBGARCHITECTS.COM

LAWRENCE CLIENT  
FARMERS DAIRY FARM, ROUTE 4  
1200 AVENUE J, MOUNTAIN VIEW, MD 20896

STRUCTURAL CONSULTANT  
STRUT AND RODDICKS, P.C.  
1200 AVENUE J, MOUNTAIN VIEW, MD 20896  
WWW.STRUTANDRODDICKS.COM

MEP CONSULTANT  
AIR CONSULTANTS, INC.  
1200 AVENUE J, MOUNTAIN VIEW, MD 20896  
WWW.AIRCONSULTANTS.COM

# FLEURS DAVE BOUTIQUE

## INTERIOR TENANT IMPROVEMENT

### 1200 N. NORTH AVENUE, BALTIMORE, MD 21204

#### DETAILS

PROJECT NO: 10-3034  
DATE: 04/2014

NO.	DESCRIPTION	DATE
01	ISSUED FOR PERMITS	04/20/2014
02	ISSUED FOR CONSTRUCTION	04/20/2014
03	ISSUED FOR PERMITS	04/20/2014
04	ISSUED FOR CONSTRUCTION	04/20/2014

CONSTRUCTION METHOD:  
CONSTRUCTION OF INTERIOR TENANT IMPROVEMENTS AND SCHEDULE FOR PERMITS APPROVAL AND SCHEDULE FOR PERMITS APPROVAL AND SCHEDULE FOR PERMITS APPROVAL AND SCHEDULE FOR PERMITS APPROVAL.

ISSUED FOR PERMITS  
DATE: 04/20/2014  
ISSUED FOR CONSTRUCTION  
DATE: 04/20/2014

A602



SECTION OF EXTERIOR WALL/PIER (W/O DOOR)

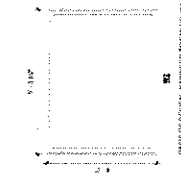

SECTION OF EXTERIOR WALL/PIER (W/O DOOR)

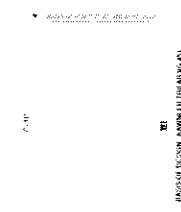

SECTION OF EXTERIOR WALL/PIER (W/O DOOR)

### WINDOW ELEVATIONS

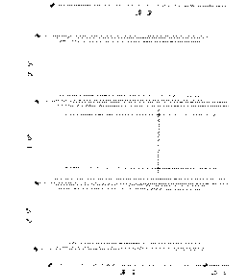

SECTION OF EXTERIOR WALL/PIER (W/O DOOR)

### ENTRANCE ELEVATION

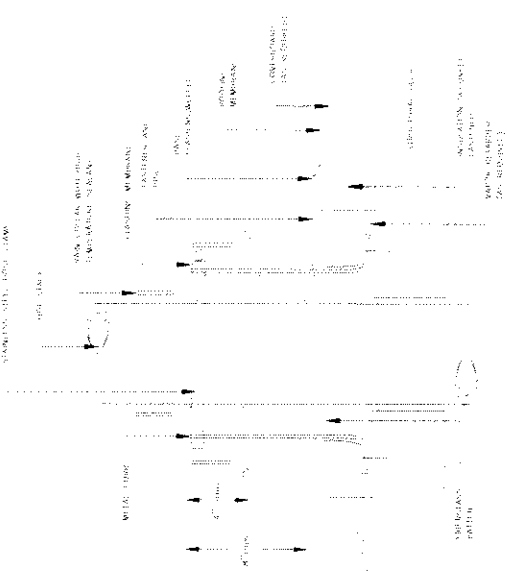

### FLUE DETAIL

# FLEURS D'AVE, INC.: D18759779

**Department ID Number:**

D18759779

**Business Name:**

FLEURS D'AVE, INC.

**Principal Office:** 

638 NORTH GILMOR STREET  
BALTIMORE MD 21217

**Resident Agent:** 

CHARLES J. SIEGEL  
STE 1200  
20 SOUTH CHARLES STREET  
BALTIMORE MD 21201

**Status:**

INCORPORATED

**Good Standing:**

THIS BUSINESS IS IN GOOD STANDING

**Business Type:**

CORPORATION

**Business Code:**

03 ORDINARY BUSINESS - STOCK

**Date of Formation/ Registration:**

04/19/2018

**State of Formation:**

MD

**Stock Status:**

STOCK

**Close Status:**

YES

PROPOSED LOCATION: 1200 W. North Avenue

## MAP SUMMARY (RECAPITULATION)

TOTAL ESTABLISHMENTS IN MAP AREA 3

"A" BEER & WINE \_\_\_\_\_

"B" BEER & WINE \_\_\_\_\_

"C" BEER & WINE \_\_\_\_\_

"D" BEER & WINE \_\_\_\_\_

"A" BEER, WINE & LIQUOR 2

"A-2" BEER, WINE & LIQUOR \_\_\_\_\_

"B" BEER, WINE & LIQUOR \_\_\_\_\_

"C" BEER, WINE & LIQUOR \_\_\_\_\_

"D" BEER, WINE & LIQUOR \_\_\_\_\_

"BD7" BEER, WINE & LIQUOR 1

ARENA \_\_\_\_\_

HOTEL/MOTEL \_\_\_\_\_

RACING \_\_\_\_\_

PREPARED BY: Jarryl (Lk) (Agent) DATE: 6/26/23

# 1200 W. North Ave

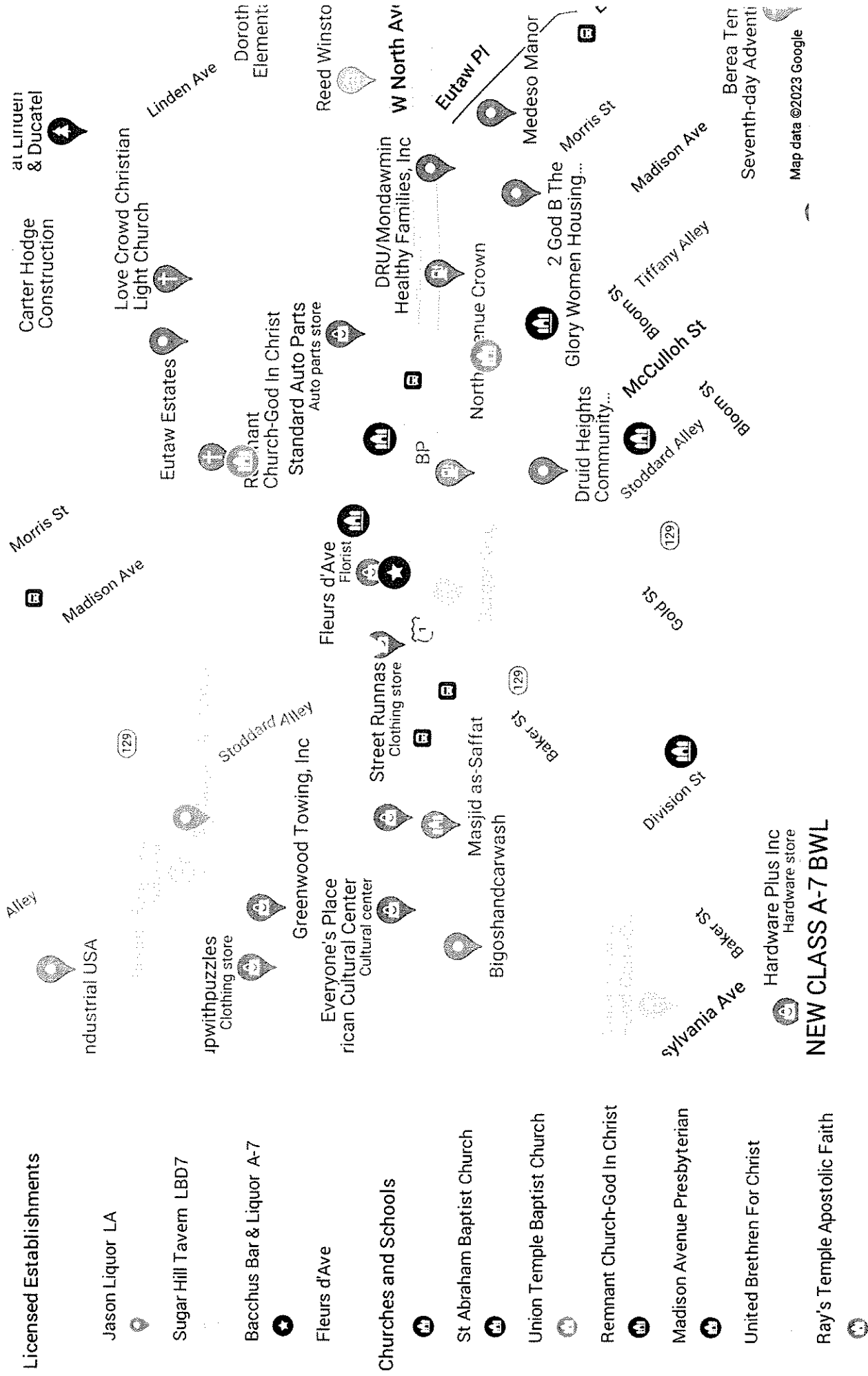

**NEW CLASS A-7 BWL**

Map data ©2023 Google

# Board of Liquor License Commissioners

For Baltimore City  
1 North Charles Street, 15th Floor  
Baltimore, Maryland, 21201

## INSPECTORS REPORT - TRANSFERS/NEW APPLICATIONS

Licensee Information (Trade Name):	<input type="text"/>
Corporation Name:	FLEURS D' AVE INC
Location Address:	1200 W NORTH AVE BALTIMORE MD 21217
License Type:	Class "A" Beer, Wine and Liquor <input type="text"/>
Is the establishment open and operating in a safe and sanitary manner? (If not open, not in comments - CLOSED or NOT OPERATING)	Yes <input type="text"/>
Is the location within 300 feet of Church and/or School?	Yes <input type="text"/>
Date Posted?	6/22/2023 <input type="text"/>
Estimated Date of Removal?	7/3/2023 <input type="text"/>
Are there any other licensed establishments within a two block radius?	Yes <input type="text"/>

Other licensed locations - Describe/Note:

PLEASE SEE MAP FOR ADDITIONAL LOCATIONS

Comments and Follow-up Items(s) (please note any issues or concerns about the location):

NEW CLASS A7 LICENSE FLORIST WILL BE ABLE TO SELL BEER, WINE AND LIQUOR

Insert Photo of Sign and location:



# Board of Liquor License Commissioners

For Baltimore City  
1 North Charles Street, 15th Floor  
Baltimore, Maryland, 21201

## POSTING SIGNS REPORT

Applicant(s) Name:

Address of Premises:

Inspector:

Date Posted:

Time Posted:

Date Rechecked:

Time Rechecked:

Manager or Owner when sign posted:

### Summary on location of sign posted:

THE SIGN IS POSTED ON THE FRONT LEFT SIDE OF THE WINDOW

### Summary on location of sign rechecked:

THE SIGN IS STILL POSTED ON THE FRONT LEFT SIDE OF THE WINDOW

### Insert Photo of Sign and location:



Attach Additional Photos

Approve

Disapprove



# NOTICE

Application has been filed with the

## Board of Liquor License Commissioners for Baltimore City

Address of Premises: 1200 W. North Avenue 21217

Class of License: Class "A-7" Beer, Wine & Liquor License

Scope of Application: New Class 'A-7' BWL License requesting delivery of alcoholic beverages

Application filed by: Fleurs d'Ave, Inc. T/A Trade Name Pending  
Brandon M. Wylie

Present Licensee(s): N/A

The hearing concerning this application will be held on or after July 6, 2023  
at 10:30 AM in City Hall; 100 N. Holliday Street, Room 215, Baltimore, Maryland 21201.

Please visit [lb.baltimorecity.gov](http://lb.baltimorecity.gov) under the link for "Hearing Schedules" for confirmation of the date, time, and place for all matters being heard by the Board.

**FOR MORE INFORMATION CALL**  
**410-396-4377**

Hon. Albert J. Matricciani, Jr., Esq.  
Aaron J. Greenfield, Esq.  
Edward L. Reisinger  
Douglas K. Paige

Chairman  
Commissioner  
Commissioner  
Executive Secretary

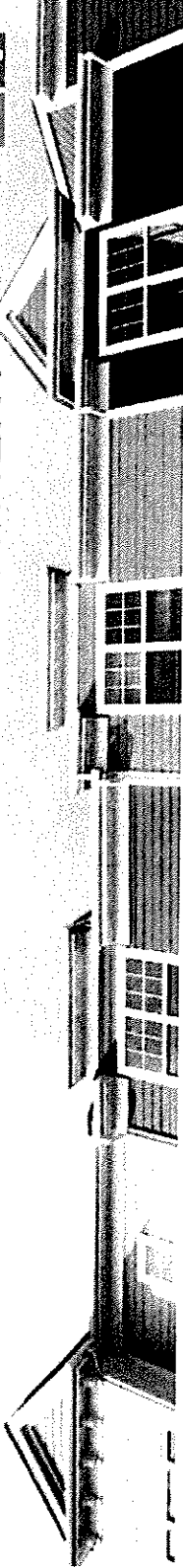

Home > Permits > My Permit Application List  
 Account: [bwylie21@me.com](mailto:bwylie21@me.com)

### My Permit Application List Logout

New! On-Line Inspection Scheduler: Now, you may schedule inspections on-line; use the Inspection Scheduler feature below

[Add Application](#)  
 [License Management](#)  
 [Inspection Scheduler](#)

Most Current(Past 3 months)  
  All Active  
  Archived  
  Deleted

Show 10 entries

Search:

Contact us	Status	ID App	Permit Number	Project Name	Create Submit Accept	Status	Fee Due	Fee Paid	Notes
Contact us	Status	109658	USE2018-56415	D'AVE	12/26/2018 12/26/2018 12/27/2018	Submitted		\$98.00	
Contact us	Status	379550	USE2023-52221	FLEURS D' AVE	4/24/2023 4/24/2023	Submitted			Archive Delete
Manage	Status	109658	USE2018-56415	D'AVE	12/26/2018 12/26/2018 12/27/2018	Submitted		\$98.00	Archive Delete

Showing 1 to 3 of 3 entries

[Previous](#)  
   
 [Next](#)

X

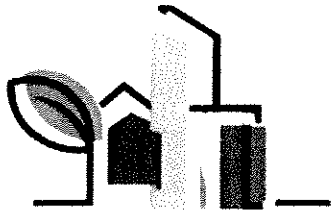

# BALTIMORE CITY DEPARTMENT OF HOUSING & COMMUNITY DEVELOPMENT



[Home](#) > [Permits](#) > Update Permit Information

**Account: bwylie21@me.com**

[Back](#)

[Logout](#)

**Project Name: FLEURS D' AVE**

[Guest Access](#)

FLORIST WITH AN A-7 BEER WINE AND LIQUOR LICENCE



Mayor Brandon M. Scott & Alice Kennedy, Commissioner

Chapter 388

(Senate Bill 588)

AN ACT concerning

**Baltimore City – 40th District – Alcoholic Beverages**

FOR the purpose of authorizing the Board of License Commissioners for Baltimore City to issue a Class C beer, wine, and liquor license in a certain area of the 40th alcoholic beverages district in Baltimore City under certain circumstances; prohibiting certain license holders in certain areas of the 40th alcoholic beverages district from selling alcoholic beverages at certain times of day; authorizing the Board to issue a Class A-7 beer, wine, and liquor license in a certain area of the 40th alcoholic beverages district in Baltimore City under certain circumstances; providing that a certain license may be issued and an existing license may be moved to a building that is within a certain distance of a place of worship or school under certain circumstances; and generally relating to alcoholic beverages in Baltimore City.

BY repealing and reenacting, without amendments,

Article – Alcoholic Beverages

Section ~~12-102 and 12-1603(a) and (b)~~, 12-1603(a) and (b), and 12-1605(a)(1)

Annotated Code of Maryland

(2016 Volume and 2022 Supplement)

BY repealing and reenacting, with amendments,

Article – Alcoholic Beverages

Section 12-1603(c)(14) and (15), 12-1605(a)(2), and 12-2005(d)

Annotated Code of Maryland

(2016 Volume and 2022 Supplement)

BY adding to

Article – Alcoholic Beverages

Section 12-1603(c)(16) and (17)

Annotated Code of Maryland

(2016 Volume and 2022 Supplement)

SECTION 1. BE IT ENACTED BY THE GENERAL ASSEMBLY OF MARYLAND,  
That the Laws of Maryland read as follows:

**Article – Alcoholic Beverages**

12-102.

This title applies only in Baltimore City.

12-1603.

(a) The alcoholic beverages districts described in this section at all times are coterminous with the legislative districts in the Legislative Districting Plan of 2012.

(b) Except as provided in subsection (c) of this section, the Board may not issue a new license in:

- (1) the 40th alcoholic beverages district;
- (2) the 41st alcoholic beverages district;
- (3) the 43rd alcoholic beverages district;
- (4) the 44th alcoholic beverages district; and
- (5) the 45th alcoholic beverages district.

(c) The Board may issue:

(14) a Class B–D–7 license in the 700 block of Washington Boulevard in the 40th alcoholic beverages district if:

(i) average daily receipts from the sale of food are at least 65% of the applicant’s total daily receipts;

(ii) the applicant executes a memorandum of understanding with a community association;

(iii) the applicant does not create a separate package goods department;

(iv) alcoholic beverages are served to patrons seated at tables; and

(v) alcoholic beverages are served only with meals to patrons provided with outdoor table service; [and]

(15) a Class B–D–7 license in the 300 block of North Charles Street in the 40th alcoholic beverages district to an establishment that has a minimum capital investment, not including the cost of land and buildings, of \$50,000 for the establishment’s facilities; ~~AND~~

**(16) A CLASS C BEER, WINE, AND LIQUOR LICENSE IN THE 3600 BLOCK OF HICKORY AVENUE IN THE 40TH ALCOHOLIC BEVERAGES DISTRICT TO A HOLDER OF A CLASS C BEER AND LIGHT WINE LICENSE; AND**

(17) A CLASS A-7 BEER, WINE, AND LIQUOR LICENSE IN THE 1200 BLOCK OF WEST NORTH AVENUE IN THE 40TH ALCOHOLIC BEVERAGES DISTRICT, IF:

(I) THE APPLICANT EXECUTES A MEMORANDUM OF UNDERSTANDING WITH THE PENN NORTH COMMUNITY ASSOCIATION;

(II) ALCOHOLIC BEVERAGES ARE SOLD ONLY AS PART OF A GIFT BASKET OR FLORAL ARRANGEMENT; AND

(III) THE APPLICANT DOES NOT HOLD OR APPLY FOR A CLASS BWLT BEER, WINE, AND LIQUOR (ON-PREMISES) TASTING LICENSE.

12-1605.

(a) (1) (i) Except as otherwise provided in this subsection, a new license may not be issued for and an existing license may not be moved to a building that is within 300 feet of the nearest point of the building of a place of worship or school.

(ii) In the 45th legislative district, a new Class A license of any type may not be issued for a building that is within 500 feet of the nearest point of the building of a place of worship or school.

(2) Paragraph (1)(i) of this subsection does not apply to:

(i) A CLASS A-7 BEER, WINE, AND LIQUOR LICENSE ISSUED UNDER § 12-1603(C)(17) OF THIS SUBTITLE;

(ii) a Class B beer and wine license outside the 46th legislative district;

~~[(ii)]~~ (iii) a Class B beer, wine, and liquor license outside the 46th legislative district;

~~[(iii)]~~ (iv) a Class B-D-7 license in the Old Goucher Revitalization District under § 12-1603(e) of this subtitle;

~~[(iv)]~~ (v) a Class C beer and wine license; and

~~[(v)]~~ (vi) a Class C beer, wine, and liquor license.

12-2005.

(d) (1) This subsection does not apply to:

- (i) a Class B beer and light wine (restaurant) license;
- (ii) a Class B beer, wine, and liquor (restaurant) license issued under § 12-1603(c)(1)(ii) of this title;
- (iii) a Class B-BWL (H-M) license;
- (iv) a Class C beer and wine license;
- (v) a Class C beer, wine, and liquor license;
- (vi) an arena license; or
- (vii) a marketplace license.

(2) For a license holder in the 40th alcoholic beverages district, the hours of sale for alcoholic beverages may not begin before 10 a.m. or end after 10 p.m.:

- (i) within an area bounded:

1. from the intersection of Reisterstown Road and Quantico Avenue, northwest on Reisterstown Road to the intersection with Wylie Avenue, northeast on Wylie Avenue to the intersection with Pimlico Road, northwest on Pimlico Road to the intersection with Dupont Avenue, east on Dupont Avenue to the intersection with Pall Mall Road, southeast on Pall Mall Road to the intersection with Edgecombe Circle North, east on Edgecombe Circle North to the intersection with Finney Avenue, south on Finney Avenue to the intersection with Oakford Avenue, west on Oakford Avenue to the intersection with Pall Mall Road, southeast on Pall Mall Road to the intersection with Loyola Northway, southwest on Loyola Northway to the intersection with Pimlico Road, southeast on Pimlico Road to the intersection with Quantico Avenue, and southwest on Quantico Avenue to the intersection with Reisterstown Road; and

2. from the intersection of Millington Avenue with Wilkens Avenue, northwest on Millington Avenue to the intersection with Frederick Avenue, northeast on Frederick Avenue to the intersection with West Pratt Street, east on West Pratt Street to the intersection with South Mount Street, south on South Mount Street to the intersection with Eagle Street, southwest on Eagle Street to the intersection with South Smallwood Street, northwest on South Smallwood Street to the intersection with Wilkens Avenue, and southwest on Wilkens Avenue to the intersection with Millington Avenue;

(ii) within the area of West North Avenue between the [1300] **1000** block of West North Avenue and the 3200 block of West North Avenue, inclusive; and

(iii) for a license holder within 250 yards in any direction of the area described in item (ii) of this paragraph.

SECTION 2. AND BE IT FURTHER ENACTED, That this Act shall take effect July 1, 2023.

**Approved by the Governor, May 3, 2023.**



## Memorandum of Understanding

This Memorandum of Understanding (the "Memorandum") is made on April 19, 2023, by and between Fleurs d' Ave, Inc, of 1200 W. North Ave, Baltimore, Maryland 21217 (hereinafter referred to as "FDV") and Penn North Community Association, of 2567 Francis St. Baltimore, Maryland 21217 (hereinafter referred to as "PNCA") for the purpose of achieving the various aims and objectives relating to the A Class A-7 Beer Wine and Liquor license for Fleurs d' Ave, Inc (the "Project").

WHEREAS FDV and PNCA desire to enter into an agreement in which FDV and PNCA will work together to complete the Project;

AND WHEREAS FDV and PNCA are desirous to enter into a Memorandum of Understanding between them, setting out the working arrangements that each of the partners agree are necessary to complete the Project;

### Purpose

The purpose of this Memorandum is to provide the framework for any future binding contract regarding the A Class A-7 Beer Wine and Liquor licence for Fleurs d' Ave, Inc between FDV and PNCA.

### Obligations of the Partners

The Partners acknowledge that no contractual relationship is created between them by this Memorandum, but agree to work together in the true spirit of partnership to ensure that there is a united visible and responsive leadership.

### Cooperation

The activities and services for the Project shall include, but not limited to:

- a. Services to be rendered by FDV include:

We agree to the terms of the liquor license approved by the state of Md. We will provide the option of having our flower bouquet and arrangements to be accompanied by alcohol in a package. We will also deliver arrangements that contain beer wine or liquor.

- b. Services to be rendered by PNCA include:

We are in support of the FDV expanding their business by adding additional value added services. We are in agreement with FDV packaging beer, wine, and liquor with their floral arrangements. We understand this is not a liquor store and beer wine and liquor will not be sold directly to customers as packaged goods.

### Resources

The Partners will endeavor to have final approval and secure any financing necessary to fulfill their individual financial contributions at the start of the planning for the development of the Project.

- a. FDV agrees to provide the following financial, material and labor resources in respect of the Project:

No Financial

## Obligation

- b. PNCA hereby agrees to provide the following financial, material and labor resources in respect of the Project:

No Financial  
Obligation

## Communication Strategy

Where it does not breach any confidentiality protocols, a spirit of open and transparent communication should be adhered to. Coordinated communications should be made with external organizations to elicit their support and further the aims of the Project.

## Liability

No liability will arise or be assumed between the Partners as a result of this Memorandum.

## Dispute Resolution

In the event of a dispute between the Partners in the negotiation of the final binding contract relating to this Project, a dispute resolution group will convene consisting of the Chief Executives of each of the Partners together with one other person independent of the Partners appointed by the Chief Executives. The dispute resolution group may receive for consideration any information it thinks fit concerning the dispute. The Partners agree that a decision of the dispute resolution group will be final. In the event the dispute resolution group is unable to make a compromise and reach a final decision, it is understood that neither party is obligated to enter into any binding contract to complete the Project.

## Term

The arrangements made by the Partners by this Memorandum shall remain in place from as long as the A Class A-7 Beer Wine and Liquor licence is enforce.

## Notice

Any notice or communication required or permitted under this Memorandum shall be sufficiently given if delivered in person or by certified mail, return receipt requested, to the address set forth in the opening paragraph or to such other address as one party may have furnished to the other in writing.

## Governing Law

This Memorandum shall be construed in accordance with the laws of the State of Maryland.

## Assignment

Neither party may assign or transfer the responsibilities or agreement made herein without the prior written consent of the non-assigning party, which approval shall not be unreasonably withheld.

## Amendment

This Memorandum may be amended or supplemented in writing, if the writing is signed by the party obligated under this Memorandum.

## Severability

If any provision of this Memorandum is found to be invalid or unenforceable for any reason, the remaining provisions will continue to be valid and enforceable. If a court finds that any provision of this Memorandum is invalid or unenforceable, but that by limiting such provision it would become valid and enforceable, then such provision will be deemed to be written, construed, and enforced as so limited.

**Prior Memorandum Superseded**

This Memorandum constitutes the entire Memorandum between the parties relating to this subject matter and supersedes all prior or simultaneous representations, discussions, negotiations, and Memorandums, whether written or oral.

**Understanding**

It is mutually agreed upon and understood by and among the Partners of this Memorandum that:

- a. Each Partner will work together in a coordinated fashion for the fulfillment of the Project.
- b. In no way does this agreement restrict involved Partners from participating in similar agreements with other public or private agencies, organizations, and individuals.
- c. To the extent possible, each Partner will participate in the development of the Project.
- d. Nothing in this memorandum shall obligate any Partner to the transfer of funds. Any endeavor involving reimbursement or contribution of funds between the Partners of this Memorandum will be handled in accordance with applicable laws, regulations, and procedures. Such endeavors will be outlined in separate agreements that shall be made in writing by representatives of the Partners involved and shall be independently authorized by appropriate statutory authority. This Memorandum does not provide such authority.
- e. This Memorandum is not intended to and does not create any right, benefit, or trust responsibility.
- f. This Memorandum will be effective upon the signature of both Partners.
- g. Any Partner may terminate its participation in this Memorandum by providing written notice to other Partner.

The following Partners support the goals and objectives of the A Class A-7 Beer Wine and Liqour licence for Fleurs d' Ave, Inc:

**Signatories**

This Agreement shall be signed on behalf of Fleurs d' Ave, Inc by Brandon M. Wylie, President, and on behalf of Penn North Community Association by Anne J. Hall, its President. This Agreement shall be effective as of the date first written above.

By:   
 Fleurs d' Ave, Inc  
 Brandon M. Wylie, its  
 President

Date: April 19, 2023

By:   
 Penn North Community Association  
 Anne J. Hall, its President

Date: 04/19/2023

**July 20, 2023**

**Applicant(s):** Jie Su  
Peter Zhang Baltimore, LLC, T/a Peter Chang  
1923 Ashland Avenue 21205

**Class:** "B" Beer, Wine & Liquor License

Application for a new Class "B" Beer, Wine and Liquor restaurant license, requesting outdoor table service and delivery of alcoholic beverages.

(a) **Applicant(s) Information:** (1) Jie Su was born in China in October of 1987. She lives in Baltimore, MD.

(b) **Ownership Breakdown:** (1) Jie Su (10%); and (2) Pergliang Zhang (90%).

(c) **Purchase Price of Business:** N/A

(d) **Qualified Voters:** Larry Lair, Johanna Stenberg, and Jelanawit Teka are qualified Baltimore City voters.

(e) **Zoning:** Applicant has applied for a USE permit, for the use of the premises 1<sup>st</sup> floor as a restaurant with outdoor dining and off-premises catering.

(f) **Corporate Standing:** Peter Zhang Baltimore, LLC is a MD LLC and as of 6/28/2023 is active and in good standing.

(g) **Posting Report:** The location was posted on 5/19/2023 and checked on 5/29/2023. This meets the 10-day rule. There are 2 licensed liquor establishments in the 4x4 area: "B" BWL- 1; and "Hotel/Motel"- 1.

(h) **Timeline:** N/A

(i) **Letters of Support/Opposition:** At this time the Board has no letter(s) of opposition or support.

In considering this request, under the provisions of Alcohol Beverages Article 4-210(A) the Board must consider the following factors: 1. The public need and desire for the license; 2. The number and location of existing license holders; 3. The potential effect on existing license holders of the license for which application is made; 4. The potential commonality or uniqueness of the services and products to be offered by the business of the applicant; 5. The impact of the license for which application is made on the health, safety, and welfare of the community, including issues relating to crime, traffic conditions, parking, or convenience; and 6. Any other factor that the local licensing Board considers necessary.

**Board's Decision**

# 2022 Application for Alcoholic Beverages License Board of Liquor License Commissioners for Baltimore City

**NEW/TRANSFER/EXPANSION/AMENDMENT(S) APPLICATION FEE - \$500.00**

INDICATE TYPE OF LICENSE APPLICATION: TRANSFER  NEW  EXPANSION OF PREMISES  AMENDMENT(S)

EXPLANATION OF REQUEST: New Class B license request CLASS TYPE: B

*Please select one option and fill out the requested information*

A) NEW LICENSE REQUEST: ADDRESS OF PROPOSED LOCATION: 1923 Ashland Avenue 21205

B) TRANSFER OF OWNERSHIP ONLY: ADDRESS OF CURRENT LICENSE: N/A

C) TRANSFER OF OWNERSHIP AND LOCATION: CURRENT ADDRESS OF LICENSED LOCATION: N/A

TRANSFER OF OWNERSHIP AND LOCATION: ADDRESS OF PROPOSED RELOCATION: N/A

D) AMENDMENT OR EXPANSION REQUEST: ADDRESS OF THE LOCATION: N/A

CORPORATE/LLC/LLP/PARTNERSHIP NAME: Peter Zhang Baltimore LLC TRADE NAME: Peter Chang

BUSINESS PHONE NUMBER: 443-888-3688 BUSINESS EMAIL ADDRESS: peterchangbaltimore@gmail.com

ATTORNEY FOR THE APPLICANT: Stephan W Fogleman Esq ADDRESS: 1720 Thames Street 21231 PHONE: 410-258-8500

Part of Premises Used (Note: Floors and Areas for Storage): 1st floor Outdoor Table Service Provided?  Yes  No Delivery of alcohol?  Yes  No

Live Entertainment provided?  Yes  No What Kind (Ex. DJ, Band, Etc.): N/A Off Premise Catering of Food and Alcohol?  Yes  No

Zoning Receipt or Current Certificate of Occupancy Permit attached to Application?  Yes  No Estimated Seating Capacity: 85

*Please note that as per Alc. Bev. Art. § 12-1407(A)(2), an application for the issuance or transfer, is not complete unless the applicant has obtained approval and/or verification from the Baltimore Municipal Zoning Appeals (BMZA)*

### 1. Applicant A

Jie Su [REDACTED] [REDACTED]

(Full name)	(Telephone no.)		E-mail (Required)
1923 Ashland Avenue #205	Baltimore MD	21205	2 months
(Residence) Street	City	State	Zip Code
10/87	F	China	(period of residency in Baltimore City)
(Month/Year of Birth)	(Sex: Male or Female)		(Place of Birth)

Check:  Yes  No Are you currently a resident of the City of Baltimore?

### 2. Applicant B

(Full name)	(Telephone no.)		E-mail (Required)
(Residence) Street	City	State	Zip Code
(Month/Year of Birth)	(Sex: Male or Female)		(Place of Birth)

Check:  Yes  No Are you currently a resident of the City of Baltimore?

### 3. Applicant C

(Full name)	(Telephone no.)		E-mail (Required)
(Residence) Street	City	State	Zip Code
(Month/Year of Birth)	(Sex: Male or Female)		(Place of Birth)

Check:  Yes  No Are you currently a resident of the City of Baltimore?

1. Has the applicant(s) been adjudged guilty of a felony in the State of Maryland or any other?  Yes  No - If yes, indicate applicant and explain.  
Applicant A  B  C

[Redacted area]

2. Has the applicant(s) been adjudged guilty of violating the laws governing the sale of any alcoholic beverage or for gambling in any State, including Maryland?  Yes  No - If yes, mark applicant and provide explanation in adjacent space provided.  
Applicant A  B  C

[Redacted area]

3. State whether the applicant(s) has ever been adjudged guilty of any offense against the laws of the State of Maryland, any other State within the United States, or against the United States (Federal Crime)?  Yes  No - If yes, mark applicant and explain.  
Applicant A  B  C

[Redacted area]

4. Has the applicant(s) ever had a license for the sale of alcoholic beverages in the State of Maryland?  Yes  No If yes, mark applicant and explain (address of location, dates that the applicant was a licensee, and the trade name).  
Applicant A  B  C

[Redacted area]

5. Has the applicant(s) ever had a liquor license suspended or revoked?  Yes  No If yes, mark applicant and explain.  
Applicant A  B  C

[Redacted area]

6. Does the applicant(s) have a financial interest in any other alcoholic beverage business or business for which an alcoholic beverage license has been applied for, granted, and issued?  Yes  No If yes, mark applicant and explain (address of location and trade name).  
Applicant A  B  C

[Redacted area]

7. Do the spouses or dependent children of any of the applicant(s) have a financial interest in any other alcoholic beverages license or business in Baltimore City or any other jurisdiction in the State of Maryland?  Yes  No If yes, mark applicant and explain (address of location and trade name).  
Applicant A  B  C

[Redacted area]

8. Are you financially interested in any other alcoholic beverages license applied, granted or issued?  Yes  No If yes, please explain.  
Applicant A  B  C

[Redacted area]

9. Is the licensed premise currently open and operating?  Yes  No If no, then provide date of last day of operation of the establishment.

new restaurant

10. Do any of the applicant(s) - personally or through an entity - have any indebtedness or other financial obligations to any manufacturer, brewer, distiller, or wholesaler at the time of making this application?  Yes  No If yes, please explain. If yes, please provide information as to the applicant(s) indebted - personally or through an entity - the amount of the indebtedness, and the name of the manufacturer, brewer, distiller, or wholesaler?

Applicant A  B  C

[Redacted area]

II. Please list the following information for the Manager of the establishment to be licensed:

Name	Address	Phone	Email
Jie Su	1923 Ashland Ave Apt 205 Baltimore 21205		

Applicants Applying as Business Entities - (Give name(s) and addresses - in Corporation list all officers (attach list if necessary) or in Limited Liability Company/Partnerships list all authorized persons.) *Please note that all licensees MUST have a FINANCIAL INTEREST in the license applied for as per Md. Gov. Art. 54-103 (a)(1). If necessary, please attach a list of the names and address of all outstanding stock holders who at the time of application own any stock of the corporation and the articles of incorporation, partnership agreement or articles of organization.*

- 1) NAME: Pengliang Zhang ADDRESS: 12007 Galena Rd. Rockville MD 20852 TITLE: owner %OF STOCK HELD: 90%
- 2) NAME: Jie Su ADDRESS: 1923 Ashland Ave Apt. 205 Baltimore 21205 TITLE: owner %OF STOCK HELD: 10%
- 3) NAME: \_\_\_\_\_ ADDRESS: \_\_\_\_\_ TITLE: \_\_\_\_\_ %OF STOCK HELD: \_\_\_\_\_
- 4) NAME: \_\_\_\_\_ ADDRESS: \_\_\_\_\_ TITLE: \_\_\_\_\_ %OF STOCK HELD: \_\_\_\_\_

*\*Extract from Law: If any affidavit or oath required under the provisions of this Act shall contain any false statements, the offender shall be deemed guilty of perjury. And upon indictment and conviction thereof, shall be subject to penalties provided by Law for that crime.*

**CERTIFICATE OF APPLICANTS:** At least one applicant whose signature appears below certifies that he/she is a current resident of Baltimore City, Maryland at the time of filing of this application. Each of said applicants hereby certifies further that if the license applied for is granted, he/she will conform to all State and County laws and regulations relating to the sale of alcoholic beverages, as well as to the rules and regulations of the Board of License Commissioners for Baltimore City, and hereby grants permission to the State Comptroller, his duly authorized deputies, inspectors and clerks, The Board of License Commissioners for Baltimore City, its duly authorized agents and employees, and any peace officer of Baltimore City or the State of Maryland to inspect and search at any and all hours, without warrant, the premises and any and all parts thereof upon and in which said business is to be conducted. If license is issued, the applicants must ensure that at least one licensee remains a resident of Baltimore City throughout the duration of this license.

[Signature]  
Signature of Applicant A

I hereby certify that on the 15 day of April, 2023 before me, the subscriber, a notary public of the State of Maryland in and for Baltimore City, personally appeared Jie Su the applicant(s) named in this application made oath in due form of law that the matter and facts contained in said application are true and correct. As witness, my hand and notarial seal.

Signature: Jennifer L Dugas  
Printed Name: Jennifer L Dugas



Signature of Applicant B

I hereby certify that on the \_\_\_\_\_ day of \_\_\_\_\_, 20\_\_\_\_ before me, the subscriber, a notary public of the State of \_\_\_\_\_ in and for \_\_\_\_\_, personally appeared \_\_\_\_\_ the applicant(s) named in this application made oath in due form of law that the matter and facts contained in said application are true and correct. As witness, my hand and notarial seal.

Signature: \_\_\_\_\_ (Notary Seal) My Commission expires \_\_\_\_\_  
Printed Name: \_\_\_\_\_

Signature of Applicant C

I hereby certify that on the \_\_\_\_\_ day of \_\_\_\_\_, 20\_\_\_\_ before me, the subscriber, a notary public of the State of \_\_\_\_\_ in and for \_\_\_\_\_, personally appeared \_\_\_\_\_ the applicant(s) named in this application made oath in due form of law that the matter and facts contained in said application are true and correct. As witness, my hand and notarial seal.

Signature: \_\_\_\_\_ (Notary Seal) My Commission expires \_\_\_\_\_  
Printed Name: \_\_\_\_\_

Name and Address of the owners of the premise/landlord: KC Ashland LLC Phone Number: [REDACTED]

STATEMENT OF OWNER OF PREMISES REQUIRED IN CONNECTION WITH ALCOHOLIC BEVERAGES LAW OF MARYLAND

(I, WE) Wai Chen HEREBY CERTIFY, That (I am, we are) the owner(s) of the property located at 1923 Ashland Ave, Baltimore, City with a Zip Code of 21205, which is named in the present application made to the Board of Liquor License Commissioners of Baltimore City under the Alcoholic Beverage Laws of Maryland and assent to the granting of the license applied for, and hereby authorize the State Comptroller, his duly authorized deputies, inspectors and clerks, the Board of Liquor License Commissioners of Baltimore City, its duly authorized agents and employees, and any peace officer of the City of Baltimore and State of Maryland, to inspect and search, without warrant, the premises upon which the business is to be conducted; and any and all parts of the building in which said business is to be conducted, at any and all hours.

[Signature]  
Signature of Owner of the Property

I hereby certify that on the 15 day of April, 2023 before me, the subscriber, a notary public of the State of Maryland, in and for Baltimore City, personally appeared Wai Chen the landlord/property owner named in this application made oath in due form of law that the matter and facts contained in said application are true and correct.

As witness, my hand and notarial seal.

Notary Signatures: [Signature]  
Notary Printed Name: Jennifer L Dugas

[Notary Seal] My Commission expires MARYLAND SEPTEMBER 16, 2025 9/16/26

JENNIFER L DUGAS  
NOTARY PUBLIC  
BALTIMORE CITY  
MY COMMISSION EXPIRES SEPTEMBER 16, 2025

The following certificates must be signed by at least 3 persons:

We, the undersigned citizens, real estate owners and registered voters in the City of Baltimore in which the business covered by the present application is to be conducted. We certify that the qualifying applicant(s) is/are personally known to us and is a resident of Baltimore City and a resident of the State of Maryland at the time of this application.

Names	Address	Signature	DOB (Month/Year)	Length of time Acquainted with the Applicant(s)

Board of Liquor License Commissioners for the City of Baltimore  
1 North Charles Street, Suite 1500, Baltimore, Maryland 21201  
Phone: 410-396-4377 Fax: 410-396-4382

Please note that this is a public document and upon request will be provided to the general members of the public.



Name and Address of the owners of the premise/landlord: \_\_\_\_\_ Phone Number: \_\_\_\_\_

**STATEMENT OF OWNER OF PREMISES REQUIRED IN CONNECTION WITH ALCOHOLIC BEVERAGES LAW OF MARYLAND**

HEREBY CERTIFY,

(I, WE) \_\_\_\_\_ That (I am, we are) the owner(s) of the property located at \_\_\_\_\_, Baltimore, City with a Zip Code of \_\_\_\_\_, which is named in the present application made to the Board of Liquor License Commissioners of Baltimore City under the Alcoholic Beverage Laws of Maryland and assent to the granting of the license applied for, and hereby authorize the State Comptroller, his duly authorized deputies, inspectors and clerks, the Board of Liquor License Commissioners of Baltimore City, its duly authorized agents and employees, and any peace officer of the City of Baltimore and State of Maryland, to inspect and search, without warrant, the premises upon which the business is to be conducted, and any and all parts of the building in which said business is to be conducted, at any and all hours.

Signature of Owner of the Property \_\_\_\_\_

I hereby certify that on the \_\_\_\_\_ day of \_\_\_\_\_, 20\_\_\_\_, before me, the subscriber, a notary public of the State of \_\_\_\_\_, in and for \_\_\_\_\_ personally appeared \_\_\_\_\_ the landlord/property owner named in this application made oath in due form of law that the matter and facts contained in said application are true and correct.

As witness, my hand and notarial seal.

Notary Signature: \_\_\_\_\_ [Notary Seal] My Commission expires \_\_\_\_\_

Notary Printed Name: \_\_\_\_\_

**The following certificates must be signed by at least 3 persons.**

We, the undersigned citizens, real estate owners and registered voters in the City of Baltimore in which the business covered by the present application is to be conducted. We certify that the qualifying applicant(s) is/are personally known to us and is a resident of Baltimore City and a resident of the State of Maryland at the time of this application.

Name	Address	Signature	DOB (Month/Year)	Length of time Acquainted with the Applicant(s)
JELAMAWIT TEKA	1907 Aliceanna St. Baltimore MD 21231		01-79	3 mos.
William Johnson	72 S. ... St. ... MD		2/79	2 months
Larry Lair	3218 Fort Ave 21241		4/56	1 month

Board of Liquor License Commissioners for the City of Baltimore  
 1 North Charles Street, Suite 1500, Baltimore, Maryland 21201  
 Phone: 410-396-4377 Fax: 410-396-4382

Please note that this is a public document and upon request will be provided to the general members of the public.

### DRAWING LEGEND

- WALL TYPE: SEE SCHEDULE FOR DETAILS
- DOOR TYPE: SEE SCHEDULE FOR DETAILS
- WINDOW TYPE: SEE SCHEDULE FOR DETAILS
- REVISIONS TO CONTRACT: REFER TO DRAWING NOTES ON THIS SHEET.
- DRAWING NOTE DESIGNATORS: REFER TO DRAWING NOTES ON THIS SHEET.
- DETAIL DESIGNATOR: REFER TO DETAIL ON SHEET A-4#
- KITCHEN EQUIPMENT: REFER TO SCHEDULE FOR DETAILS.

### DOOR SCHEDULE

NO.	SLAT	DOOR	FRAME	FINISH	HANDLE	REMARKS
1	3/4" x 1/2" x 1/2"	6'0" x 8'0"	ALUMINUM	WOOD GRAIN	WOOD GRAIN	STANDARD
2	3/4" x 1/2" x 1/2"	6'0" x 8'0"	ALUMINUM	WOOD GRAIN	WOOD GRAIN	STANDARD
3	3/4" x 1/2" x 1/2"	6'0" x 8'0"	ALUMINUM	WOOD GRAIN	WOOD GRAIN	STANDARD
4	3/4" x 1/2" x 1/2"	6'0" x 8'0"	ALUMINUM	WOOD GRAIN	WOOD GRAIN	STANDARD
5	3/4" x 1/2" x 1/2"	6'0" x 8'0"	ALUMINUM	WOOD GRAIN	WOOD GRAIN	STANDARD
6	3/4" x 1/2" x 1/2"	6'0" x 8'0"	ALUMINUM	WOOD GRAIN	WOOD GRAIN	STANDARD
7	3/4" x 1/2" x 1/2"	6'0" x 8'0"	ALUMINUM	WOOD GRAIN	WOOD GRAIN	STANDARD
8	3/4" x 1/2" x 1/2"	6'0" x 8'0"	ALUMINUM	WOOD GRAIN	WOOD GRAIN	STANDARD
9	3/4" x 1/2" x 1/2"	6'0" x 8'0"	ALUMINUM	WOOD GRAIN	WOOD GRAIN	STANDARD
10	3/4" x 1/2" x 1/2"	6'0" x 8'0"	ALUMINUM	WOOD GRAIN	WOOD GRAIN	STANDARD
11	3/4" x 1/2" x 1/2"	6'0" x 8'0"	ALUMINUM	WOOD GRAIN	WOOD GRAIN	STANDARD
12	3/4" x 1/2" x 1/2"	6'0" x 8'0"	ALUMINUM	WOOD GRAIN	WOOD GRAIN	STANDARD
13	3/4" x 1/2" x 1/2"	6'0" x 8'0"	ALUMINUM	WOOD GRAIN	WOOD GRAIN	STANDARD
14	3/4" x 1/2" x 1/2"	6'0" x 8'0"	ALUMINUM	WOOD GRAIN	WOOD GRAIN	STANDARD
15	3/4" x 1/2" x 1/2"	6'0" x 8'0"	ALUMINUM	WOOD GRAIN	WOOD GRAIN	STANDARD
16	3/4" x 1/2" x 1/2"	6'0" x 8'0"	ALUMINUM	WOOD GRAIN	WOOD GRAIN	STANDARD
17	3/4" x 1/2" x 1/2"	6'0" x 8'0"	ALUMINUM	WOOD GRAIN	WOOD GRAIN	STANDARD
18	3/4" x 1/2" x 1/2"	6'0" x 8'0"	ALUMINUM	WOOD GRAIN	WOOD GRAIN	STANDARD
19	3/4" x 1/2" x 1/2"	6'0" x 8'0"	ALUMINUM	WOOD GRAIN	WOOD GRAIN	STANDARD
20	3/4" x 1/2" x 1/2"	6'0" x 8'0"	ALUMINUM	WOOD GRAIN	WOOD GRAIN	STANDARD

### DRAWING NOTES:

1. EXTERIOR WALLS ARE EXISTING TO REMAIN W/ EXISTING INSULATION FROM SEPARATE PERMIT. NO WORK ON EXTERIOR WALL ON THIS PERMIT.
2. NEW COMMERCIAL KITCHEN, WASHABLE CEILING SURFACE IN KITCHEN (REFER TO KITCHEN PLAN & EQUIPMENT SCHEDULE ON SHEET A-3)
3. WASHABLE WALLS & CEILING SURFACES IN KITCHEN
4. NEW WALLS & BATHROOM
5. SOAP AND PAPER TOWEL DISPENSERS SHALL BE SUPPLIED ADJACENT TO ALL HAND WASHING LOCATIONS AS REQUIRED AND INSTALLED IN ACCORDANCE W/ ADA GUIDELINES (REFER TO DETAILS ON SHEET A-4)
6. COUNTERTOP CABINET UNITS FOR REGISTER AREAS, CABINETS FASTENED TO CONCRETE DECK. COUNTERTOP SHALL HAVE A FINISHED PORTION W/ MIN 36" LENGTH AND MAX 36" HT AFF.
7. WINDOWS EXISTING TO REMAIN

### NOTE:

- GARBAGE / DUMPSTER AREA WITHIN 30' OF REAR DOORS.
- ANY TRANSITIONS BETWEEN FLOORING SHALL BE COVERED W/ THRESHOLD OR ANTI-TRIP TRANS.
- WALL TO BE SUPPLIED W/ MOP AND BROOM RACK

### GENERAL NOTES

- THE GENERAL CONTRACTOR SHALL COMPLY WITH ALL HEALTH AND LIFE SAFETY REQUIREMENTS AS DIRECTED BY BALTIMORE CITY AND THE STATE OF MARYLAND
- ALL CONSTRUCTION WORK SHALL BE IN ACCORDANCE WITH ALL APPLICABLE BUILDING CODES AND LOCAL AMENDMENTS
- ALL INTERIOR PARTITIONS SHALL BE LABELLED & SANDED SMOOTH TO RECEIVE PAINT OR WALL FINISH MATERIAL
- INTERIOR LIGHTING SELECTION CLIENT'S CHOICE
- INTERIOR FINISHES ARE THE CLIENT'S CHOICE
- DOOR STYLE CLIENT'S CHOICE
- ALL DOORS SHALL BE 6'-8" IN HEIGHT
- FIELD MEASURE AS REQUIRED FOR ALL DOORS, WINDOW OPENINGS & MILLWORK, PRIOR TO FABRICATION
- USE WATER RESISTANT GYPSUM BOARD AT ALL AREAS SUBJECT TO MOISTURE OR WHERE TILLS USED

### LEGEND

- NEW NON BEARING INTERIOR PARTITION (27X47 NON-RATED WALL W/ 1/2" DRYWALL)
- NEW WET WALL FOR PIPING (27X6" NON-RATED WALL W/ 1/2" DRYWALL)
- EXISTING 1-HR FIRE RATED INTERIOR PARTITION TO REMAIN
- EXISTING PARTITION TO REMAIN
- NOT IN SCOPE

### FIRE CODE PLAN SYMBOLS

- EMERGENCY EGRESS LIGHT INDICATED THUS
- FIRE-RETARDANCY EXIT SIGN INDICATED THUS

APPROX. 3,068 GSF

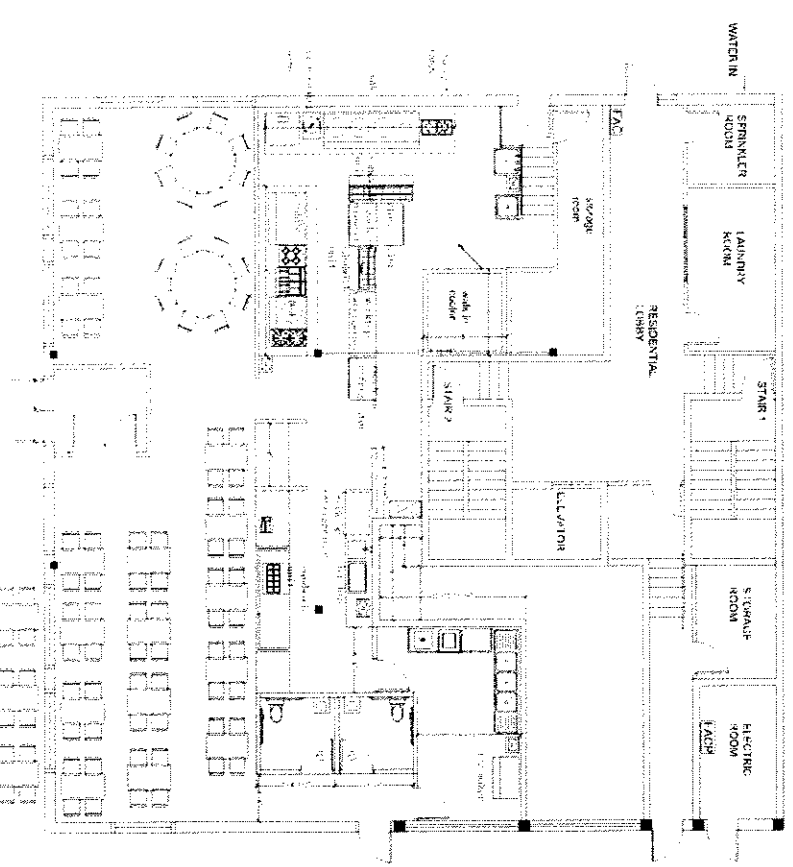

PRECISION DIM SUM FIRE CODE PLAN  
SCALE: 3/8" = 1'-0"

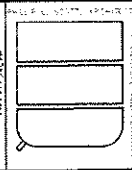

Project Title  
DIM SUM  
Project address  
1923 ASHLAND AVE  
BALTIMORE, MD 21205

FLOOR PLANS & SCHEDULE

A-2

## PETER ZHANG BALTIMORE LLC: W23291073

**Department ID Number:**

W23291073

**Business Name:**

PETER ZHANG BALTIMORE LLC

**Principal Office:** 

1923 ASHLAND AVE  
BALTIMORE MD 21205

**Resident Agent:** 

PENGLIANG ZHANG  
1923 ASHLAND AVE  
BALTIMORE MD 21205

**Status:**

ACTIVE

**Good Standing:**

THIS BUSINESS IS IN GOOD STANDING

**Business Type:**

DOMESTIC LLC

**Business Code:**

20 ENTITIES OTHER THAN CORPORATIONS

**Date of Formation/Registration:**

09/16/2022

**State of Formation:**

MD

**Stock Status:**

N/A

**Close Status:**

N/A

PROPOSED LOCATION: 1923 Ashland Ave

## MAP SUMMARY (RECAPITULATION)

TOTAL ESTABLISHMENTS IN MAP AREA 2

"A" BEER & WINE \_\_\_\_\_

"B" BEER & WINE \_\_\_\_\_

"C" BEER & WINE \_\_\_\_\_

"D" BEER & WINE \_\_\_\_\_

"A" BEER, WINE & LIQUOR \_\_\_\_\_

"A-2" BEER, WINE & LIQUOR \_\_\_\_\_

"B" BEER, WINE & LIQUOR 1

"C" BEER, WINE & LIQUOR \_\_\_\_\_

"D" BEER, WINE & LIQUOR \_\_\_\_\_

"BD7" BEER, WINE & LIQUOR \_\_\_\_\_

ARENA \_\_\_\_\_

HOTEL/MOTEL 1

RACING \_\_\_\_\_

PREPARED BY: Chase DATE: 5/30/23

# 1923 Ashland Ave

**Licensed Establishments**

- Peter Chang LB
- Helmand Kabobi LB
- Residence Inn by Marriott Baltimore at The Johns Hopkins Medical Campus LBHM

**Other Landmarks and Points of Interest:**

- Medicine University... drug store
- 929 Apartments, Baltimore
- Ashland Parking Garage
- Johns Hopkins Tech Hub Computer store
- The Harbor Bank of Maryland (Science and...)
- Photo-Graphix
- 7-Eleven Convenience store
- Residence Inn by Marriott Baltimore at...
- Preclinical Teaching Building PCTB
- Preclinical Teaching Building
- Biophysics Building
- Weich Medical Library
- Washington Garage
- Washington

**Streets:** Ashland Ave, N Castle St, N Wolfe St, N Chapel St, E Madison St, Rutland Ave.

**Map Data:** Map data ©2023 Google

# Board of Liquor License Commissioners

For Baltimore City  
1 North Charles Street, 15th Floor  
Baltimore, Maryland, 21201

## INSPECTORS REPORT - TRANSFERS/NEW APPLICATIONS

Licensee Information (Trade Name):

Peter Chang

Corporation Name:

Peter Zhang Baltimore LLC

Location Address:

1923 Ashland Ave

License Type:

Class "B" Beer, Wine and Liquor

Is the establishment open and operating in a safe and sanitary manner?  
(If not open, not in comments - CLOSED or NOT OPERATING)

No

Is the location within 300 feet of Church and/or School?

No

Date Posted?

5/19/2023

Estimated Date of Removal?

5/29/2023

Are there any other licensed establishments within a two block radius?

Yes

Other licensed locations - Describe/Note:

Please see maps for additional locations

Comments and Follow-up Items(s) (please note any issues or concerns about the location):

Filed application for New "B" license with outdoor table service and off premise catering. The establishment is under construction.

Insert Photo of Sign and location:

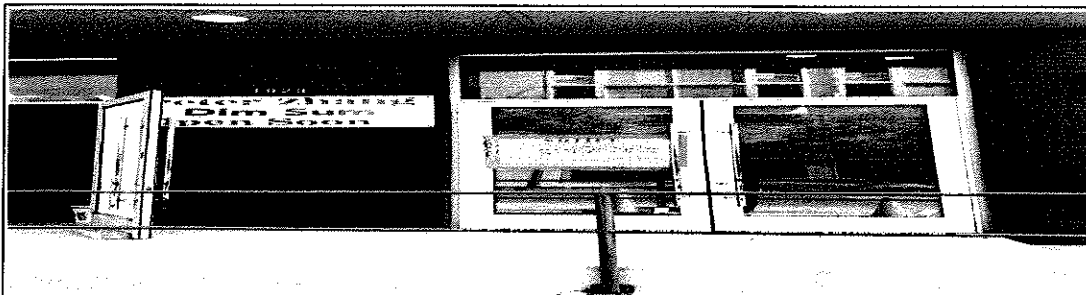

Attach Additional Photos

Inspector Name

Date and Time

i:\0#.w\baltimore\terri.chase

5/31/2023

12:36:49 PM

Name of Licensee (if present)

Approve

Disapprove

# Board of Liquor License Commissioners

For Baltimore City  
1 North Charles Street, 15th Floor  
Baltimore, Maryland, 21201

## POSTING SIGNS REPORT

Applicant(s) Name:

Jie Su

Address of Premises:

1923 Ashland Ave

Inspector:

i:\0#.w\baltimore\terri.chase

Date Posted:

5/19/2023

Time Posted:

1:00 PM

Date Rechecked:

5/29/2023

Time Rechecked:

2:00 PM

Manager or Owner when sign posted:

N/A

Summary on location of sign posted:

The sign is posted on the front door.

Summary on location of sign rechecked:

The sign is still posted on the front door.

Insert Photo of Sign and location:

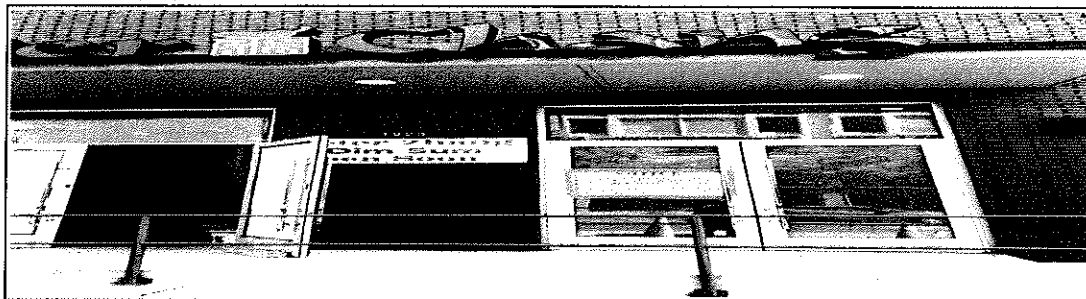

Attach Additional Photos

Approve

Disapprove



# NOTICE

*Application has been filed with the*

Board of Liquor License Commissioners for Baltimore City

Address of Premises: 1923 Ashland Avenue 21205  
Class of License: Class "B" Beer, Wine & Liquor License  
Scope of Application: New restaurant requesting outdoor table service and off-premises catering

Application filed by: Peter Zhang Baltimore, LLC TA Peter Chang  
Jie Su  
Present Licensee(s): N/A

The hearing concerning this application will be held on or after June 1, 2023 at 10:30 AM in City Hall; 100 N. Holliday Street, Room 215, Baltimore, Maryland 21201. Please visit [lb.baltimorecity.gov](http://lb.baltimorecity.gov) under the link for "Hearing Schedules" for confirmation of the date, time, and place for all matters being heard by the Board.

**FOR MORE INFORMATION CALL**

Hon. Albert J. Matricciani, Jr., Esq.

Chairman





Stephan Fogleman

---

**City of Baltimore - ePermits - USE Fee Paid - USE2023-51497**

1 message

---

**DHCD Email Service** <no\_reply.DHCD@baltimorecity.gov> Sun, Apr 23, 2023 at 10:12 AM

Reply-To: no\_reply.DHCD@baltimorecity.gov

To:

---

Your Online fee payment has been posted to your USE permit application.

Project name: 1923 ASHLAND AVE

Property Address(1st): 1923ASHLAND AVE

Permit number: USE2023-51497

Fee Type: USE Permit Fee

Notes: Payment ID: 9000299007 , Amount: 98.00

---

**July 20, 2023**

**Applicant(s):** Jeffeary Miskiri and Kevin Satia-Watng Nanji  
Miss Toya's Creole House Northwood, LLC T/a Miss Toya's Creole House  
1500 Havenwood Road k/a 1532-34 Havenwood Road, Suite B-170 21218

**Class:** "B" Beer, Wine & Liquor License

Application for a new Class "B" Beer, Wine and Liquor restaurant license, requesting live entertainment and outdoor table service.

**(a) Applicant(s) Information:** (1) Jeffrey Miskiri was born in Washington, DC in September of 1987. He lives in Bowie, MD; and (2) Kevin Satia-Watng Nanji was born in Silver Spring, MD in March of 1995. He lives in Baltimore, MD. Mr. Miskiri is presently the licensee with financial interest at (1) 3345 14<sup>th</sup> Street NW, Washington, DC t/a Creole on 14<sup>th</sup>; (2) 709 H Street NE, Washington, DC t/a Poboy Jim; (3) 5557 Baltimore Avenue, Hyattsville, MD 20781 t/a Suga and Spice; (4) 3216 Pennsylvania Avenue, Washington, DC t/a Miss Toya's Southern Kitchen; (5) 225 Boardwalk Drive, Gaithersburg, MD t/a Miss Toya's Southern Kitchen Rio; and (6) 923 Ellsworth Drive, Silver Spring, MD t/a Miss Toya's Creole House.

**(b) Ownership Breakdown:** (1) Jeffrey Miskiri (100%); and (2) Kevin Satia-Watng Nanji (0%).

**(c) Purchase Price of Business:** N/A

**(d) Qualified Voters:** Palestine Williams, Brittany Johnson, and Bianca Williams are qualified Baltimore City voters.

**(e) Zoning:** Applicant has applied for a USE permit, for the use of the premises known as 1532-1534 Havenwood Road, Suite B-170 as a restaurant with outdoor table service and live entertainment.

**(f) Corporate Standing:** Miss Toya's Creole House Northwood, LLC is a MD LLC and as of 6/28/2023 is active and in good standing.

**(g) Posting Report:** The location was posted on 6/9/2023 and checked on 6/19/2023. This meets the 10-day rule. There are 0 licensed liquor establishments in the 4x4 area:

**(h) Timeline:** N/A

**(i) Letters of Support/Opposition:** At this time the Board has one letter of support from Hillen Road Improvement Association.

In considering this request, under the provisions of Alcohol Beverages Article 4-210(A) the Board must consider the following factors: 1. The public need and desire for the license; 2. The number and location of existing license holders; 3. The potential effect on existing license holders of the license for which application is made; 4. The potential commonality or uniqueness of the services and products to be offered by the business of the applicant; 5. The impact of the license for which application is made on the health, safety, and welfare of the community, including issues relating to crime, traffic conditions, parking, or convenience; and 6. Any other factor that the local licensing Board considers necessary.

**Board's Decision**

# 2022 Application for Alcoholic Beverages License Board of Liquor License Commissioners for Baltimore City

**NEW/TRANSFER/EXPANSION/AMENDMENT(S) APPLICATION FEE - \$600.00**

INDICATE TYPE OF LICENSE APPLICATION: TRANSFER  NEW  EXPANSION OF PREMISES  AMENDMENT(S)

EXPLANATION OF REQUEST: Application for a new Class B liquor license CLASS TYPE: B

*Please select one option and fill out the requested information*

A) NEW LICENSE REQUEST: ADDRESS OF PROPOSED LOCATION: 1500 Havenwood Road k/a 1532-1534 Havenwood Road, Suite B-170, Baltimore MD 21218

B) TRANSFER OF OWNERSHIP ONLY: ADDRESS OF CURRENT LICENSE: \_\_\_\_\_

C) TRANSFER OF OWNERSHIP AND LOCATION: CURRENT ADDRESS OF LICENSED LOCATION: \_\_\_\_\_

TRANSFER OF OWNERSHIP AND LOCATION: ADDRESS OF PROPOSED RELOCATION: \_\_\_\_\_

D) AMENDMENT OR EXPANSION REQUEST: ADDRESS OF THE LOCATION: \_\_\_\_\_

CORPORATE/LLC/LLP/PARTNERSHIP NAME: Miss Toya's Creole House Northwood, LLC TRADE NAME: Miss Toya's Creole House

BUSINESS PHONE NUMBER: 202-910-8348 BUSINESS EMAIL ADDRESS: jeff@miskirihospitalitygroup.com

ATTORNEY FOR THE APPLICANT: Caroline L. Hecker, Esq. ADDRESS: 25 S. Charles Street, 21st Floor, Baltimore MD 21201 PHONE: 410-727-6600

Part of Premises Used (Note: floors and Areas for Storage): 1st Floor Outdoor Table Service Provided?  Yes  No Delivery of alcohol?  Yes  No  
 Live Entertainment provided?  Yes  No What Kind (Ex. DJ Band Etc.)? jazz trio, DJ for special occasion Off Premises Catering of Food and Alcohol?  Yes  No  
 Zoning Receipt or Current Certificate of Occupancy Permit attached to Application?  Yes  No Estimated Seating Capacity: 150

*Please note that as per Alc. Bev. Art. § 12-1407(A)(2), an application for the issuance or transfer, is not complete unless the applicant has obtained approval and/or verification from the Baltimore Municipal Zoning Appeals (BMZA)*

**1. Applicant A**

Jeffrey Miskiri \_\_\_\_\_  
 (Full name) (Telephone no.) E-mail (Required)  
14916 Running Horse Place Bowie MD 20715 N/A  
 (Residence) Street City State Zip Code (period of residency in Baltimore City)  
09/1987 Male Washington, DC  
 (Month/Year of Birth) (Sex: Male or Female) (Place of Birth)  
 Check:  Yes  No Are you currently a resident of the City of Baltimore?

**2. Applicant B**

Kevin Satia-Watng Nanji \_\_\_\_\_  
 (Full name) (Telephone no.) E-mail (Required)  
3818 Fern Hill Avenue Baltimore MD 21215 >1 year  
 (Residence) Street City State Zip Code (period of residency in Baltimore City)  
03/1995 Male Silver Spring, MD  
 (Month/Year of Birth) (Sex: Male or Female) (Place of Birth)  
 Check:  Yes  No Are you currently a resident of the City of Baltimore?

**3. Applicant C**

\_\_\_\_\_  
 (Full name) (Telephone no.) E-mail (Required)  
 \_\_\_\_\_  
 (Residence) Street City State Zip Code (period of residency in Baltimore City)  
 \_\_\_\_\_  
 (Month/Year of Birth) (Sex: Male or Female) (Place of Birth)  
 Check:  Yes  No Are you currently a resident of the City of Baltimore?

1. Has the applicant(s) been adjudged guilty of a felony in the State of Maryland or any other?  Yes  No - If yes, indicate applicant and explain.

Applicant A  B  C

2. Has the applicant(s) been adjudged guilty of violating the laws governing the sale of any alcoholic beverage or for gambling in any State, including Maryland?  Yes  No - If yes, mark applicant and provide explanation in adjacent space provided.

Applicant A  B  C

3. State whether the applicant(s) has ever been adjudged guilty of any offense against the laws of the State of Maryland, any other State within the United States, or against the United States (Federal Crime)?  Yes  No - If yes, mark applicant and explain.

Applicant A  B  C

4. Has the applicant(s) ever had a license for the sale of alcoholic beverages in the State of Maryland?  Yes  No If yes, mark applicant and explain (address of location, dates that the applicant was a licensee, and the trade name).

Applicant A  B  C

See attached list.

5. Has the applicant(s) ever had a liquor license suspended or revoked?  Yes  No If yes, mark applicant and explain.

Applicant A  B  C

6. Does the applicant(s) have a financial interest in any other alcoholic beverage business or business for which an alcoholic beverage license has been applied for, granted, and issued?  Yes  No If yes, mark applicant and explain (address of location and trade name).

Applicant A  B  C

See attached list.

7. Do the spouses or dependent children of any of the applicant(s) have a financial interest in any other alcoholic beverages license or business in Baltimore City or any other jurisdiction in the State of Maryland?  Yes  No If yes, mark applicant and explain (address of location and trade name).

Applicant A  B  C

8. Are you financially interested in any other alcoholic beverages license applied, granted or issued?  Yes  No If yes, please explain.

Applicant A  B  C

9. Is the licensed premise currently open and operating?  Yes  No If no, then provide date of last day of operation of the establishment.

N/A - New license

10. Do any of the applicant(s) - personally or through an entity - have any indebtedness or other financial obligations to any manufacturer, brewer, distiller, or wholesaler at the time of making this application?  Yes  No If yes, please explain. If yes, please provide information as to the applicant(s) indebted - personally or through an entity - the amount of the indebtedness, and the name of the manufacturer, brewer, distiller, or wholesaler?

Applicant A  B  C

Page 2 continued

Applicant A is also a licensee with a financial interest in each of the following liquor licenses:

1. Creole on 14<sup>th</sup>; 3345 14th Street NW, Washington, DC
2. Poboy Jim; 709 H Street NE, Washington, DC
3. Suga and Spice; 5557 Baltimore Avenue, Suite 100
4. Miss Toya's Southern Kitchen; 3216 Pennsylvania Avenue, Washington, DC
5. Miss Toya's Southern Kitchen Rio; 225 Boardwalk Drive, Gaithersburg, MD
6. Miss Toya's Creole House; 923 Ellsworth Drive, Silver Spring, MD

**II. Please list the following information for the Manager of the establishment to be licensed:**

Name	Address	Phone	Email
Jeffrey Miskiri	1532-1534 Havenwood Road, Suite B-170, Baltimore MD 21218		

Applicants Applying as Business Entities - (Give name(s) and addresses - in Corporation list all officers (attach list if necessary) or in Limited Liability Company/Partnerships list all authorized persons.) *Please note that all licensees MUST have a FINANCIAL INTEREST in the license applied for as per Alc. Bev. Art. § 4-10B (a)(1). If necessary, please attach a list of the names and address of all outstanding stock holders who at the time of application own any stock of the corporation and the articles of incorporation, partnership agreement or articles of organization.*

- 1) NAME: Jeffrey Miskiri ADDRESS: 1532-1534 Havenwood Road, Suite B-170, Baltimore MD 21218 TITLE: CEO %OF STOCK HELD: 100%
- 2) NAME: Kevin Nanji ADDRESS: 3818 Fernhill Ave, Baltimore, MD 21215 TITLE: Manager %OF STOCK HELD: 0%
- 3) NAME: \_\_\_\_\_ ADDRESS: \_\_\_\_\_ TITLE: \_\_\_\_\_ %OF STOCK HELD: \_\_\_\_\_
- 4) NAME: \_\_\_\_\_ ADDRESS: \_\_\_\_\_ TITLE: \_\_\_\_\_ %OF STOCK HELD: \_\_\_\_\_

*\*Extract from Law: If any affidavit or oath required under the provisions of this Act shall contain any false statements, the offender shall be deemed guilty of perjury. And upon indictment and conviction thereof, shall be subject to penalties provided by Law for that crime.*

**CERTIFICATE OF APPLICANTS:** At least one applicant whose signature appears below certifies that he/she is a current resident of Baltimore City, Maryland at the time of filing of this application. Each of said applicants hereby certifies further that if the license applied for is granted, he/she will conform to all State and County laws and regulations relating to the sale of alcoholic beverages, as well as to the rules and regulations of the Board of License Commissioners for Baltimore City, and hereby grants permission to the State Comptroller, his duly authorized deputies, inspectors and clerks, The Board of License Commissioners for Baltimore City, its duly authorized agents and employees, and any peace officer of Baltimore City or the State of Maryland to inspect and search at any and all hours, without warrant, the premises and any and all parts thereof upon and in which said business is to be conducted. If license is issued, the applicants must ensure that at least one licensee remains a resident of Baltimore City throughout the duration of this license.

[Signature]  
Signature of Applicant A

I hereby certify that on the 28 day of April, 2023 before me, the subscriber, a notary public of the State of Maryland in and for PE personally appeared Jeffrey Miskiri the applicant(s) named in this application made oath in due form of law that the matter and facts contained in said application are true and correct. As witness, my hand and notarial seal.

Signature: [Signature] (Notary Seal) My Commission expires June 8 2024

Printed Name: Olufemi Isir

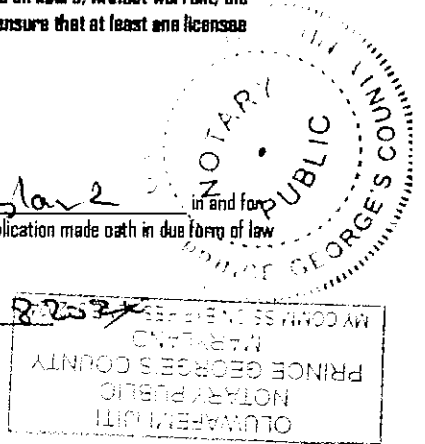

[Signature]  
Signature of Applicant B

I hereby certify that on the 29 day of April, 2023 before me, the subscriber, a notary public of the State of Maryland in and for PE personally appeared Kevin Nanji the applicant(s) named in this application made oath in due form of law that the matter and facts contained in said application are true and correct. As witness, my hand and notarial seal.

Signature: [Signature] (Notary Seal) My Commission expires June 8 2024

Printed Name: Olufemi Isir

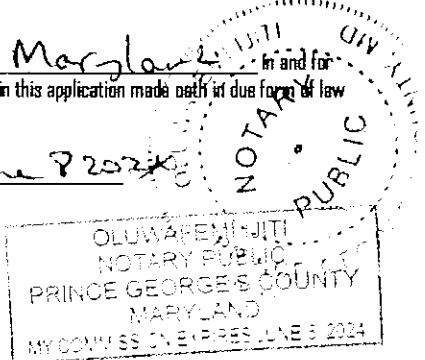

Signature of Applicant C

I hereby certify that on the \_\_\_\_\_ day of \_\_\_\_\_, 20\_\_\_\_, before me, the subscriber, a notary public of the State of \_\_\_\_\_ in and for \_\_\_\_\_ personally appeared \_\_\_\_\_ the applicant(s) named in this application made oath in due form of law that the matter and facts contained in said application are true and correct. As witness, my hand and notarial seal.

Signature: \_\_\_\_\_ (Notary Seal) My Commission expires \_\_\_\_\_

Printed Name: \_\_\_\_\_



Name and Address of the owners of the premise/landlord: MCB Northwood, LLC, 2092 Clipper Park Road, Suite 105, Baltimore, MD 21211 Phone Number: [REDACTED]

STATEMENT OF OWNER OF PREMISES REQUIRED IN CONNECTION WITH ALCOHOLIC BEVERAGES LAW OF MARYLAND

(I, WE) MCB Northwood, LLC HEREBY CERTIFY, That (I am, we are) the owner(s) of the property located at 1500 Havenwood Road, Baltimore, City with a Zip Code of 21218, which is named in the present application made to the Board of Liquor License Commissioners of Baltimore City under the Alcoholic Beverage Laws of Maryland and assent to the granting of the license applied for, and hereby authorize the State Comptroller, his duly authorized deputies, inspectors and clerks, the Board of Liquor License Commissioners of Baltimore City, its duly authorized agents and employees, and any peace officer of the City of Baltimore and State of Maryland, to inspect and search, without warrant, the premises upon which the business is to be conducted, and any and all parts of the building in which said business is to be conducted, at any and all hours.

[Signature]  
Signature of Owner of the Property

I hereby certify that on the 1st day of May, 2023 before me, the subscriber, a notary public of the State of Maryland in and for Baltimore, personally appeared P. David Bramble the landlord/property owner named in this application made oath in due form of law that the matter and facts contained in said application are true and correct.

As witness, my hand and notarial seal.

Notary Signature: Angela L. Martin

(Notary Seal) My Commission expires 07/11/2024

Notary Printed Name: Angela L. Martin

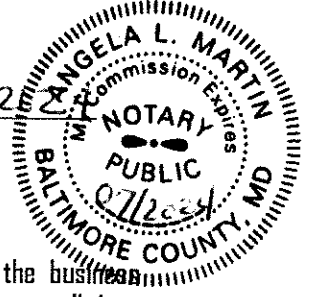

The following certificates must be signed by at least 3 persons.

We, the undersigned citizens, real estate owners and registered voters in the City of Baltimore in which the business covered by the present application is to be conducted. We certify that the qualifying applicant(s) is/are personally known to us and is a resident of Baltimore City and a resident of the State of Maryland at the time of this application.

Names	Address	Signature	DOB (Month/Year)	Length of time Acquainted with the Applicant(s)
Lavelle Allen	3821 Yolando Road Baltimore, MD 21218	<u>[Signature]</u>	11/1987	10 years
Chimiya Polk	711 Wildwood Pkwy Baltimore, MD 21229	<u>[Signature]</u>	07/1988	3 Years
Palestine Williams	1105 Holmen Rd Baltimore MD 21239	<u>[Signature]</u>		3 Years
Evan Nebblet	3818 Fern hill Ave Baltimore MD 21215	<u>[Signature]</u>	02/1994	10 years
D'Anita Parker	1539 Barret Rd Gwynn Oak, MD 21207	<u>[Signature]</u>	5/1956	4 Years

Board of Liquor License Commissioners for the City of Baltimore  
1 North Charles Street, Suite 1500, Baltimore, Maryland 21201  
Phone: 410-396-4377 Fax: 410-396-4382

Please note that this is a public document and upon request will be provided to the general members of the public.

Name and Address of the owners of the premise/landlord: MCB Northwood, LLC, 2002 Clipper Park Road, Suite 106, Baltimore, MD 21211 Phone Number: 410-662-0104

**STATEMENT OF OWNER OF PREMISES REQUIRED IN CONNECTION WITH ALCOHOLIC BEVERAGES LAW OF MARYLAND**

(I, WE) MCB Northwood, LLC HEREBY CERTIFY, That (I am, we are) the owner(s) of the property located at 1532-1534 Havenwood Road, Suite B-170, Baltimore, City with a Zip Code of 21218, which is named in the present application made to the Board of Liquor License Commissioners of Baltimore City under the Alcoholic Beverage Laws of Maryland and assent to the granting of the license applied for, and hereby authorize the State Comptroller, his duly authorized deputies, inspectors and clerks, the Board of Liquor License Commissioners of Baltimore City, its duly authorized agents and employees, and any peace officer of the City of Baltimore and State of Maryland, to inspect and search, without warrant, the premises upon which the business is to be conducted, and any and all parts of the building in which said business is to be conducted, at any and all hours.

\_\_\_\_\_  
Signature of Owner of the Property

I hereby certify that on the \_\_\_\_\_ day of \_\_\_\_\_, 20\_\_\_\_, before me, the subscriber, a notary public of the State of \_\_\_\_\_, in and for \_\_\_\_\_, personally appeared \_\_\_\_\_ the landlord/property owner named in this application made oath in due form of law that the matter and facts contained in said application are true and correct.

As witness, my hand and notarial seal.

Notary Signature: \_\_\_\_\_ (Notary Seal) My Commission expires \_\_\_\_\_

Notary Printed Name: \_\_\_\_\_

**The following certificates must be signed by at least 3 persons.**

We, the undersigned citizens, real estate owners and registered voters in the City of Baltimore in which the business covered by the present application is to be conducted. We certify that the qualifying applicant(s) is/are personally known to us and is a resident of Baltimore City and a resident of the State of Maryland at the time of this application.

Names	Address	Signature	DOB (Month/Year)	Length of time Acquainted with the Applicant(s)
Lavell Allen	3821 Yolando Road Baltimore, MD 21218	<i>L.A.</i>	11/1989	10 years
<del>Chimmya Park</del>	<del>711 Wildwood Pkwy Baltimore, MD 21229</del>	<del><i>Chimmya Park</i></del>	<del>07/1988</del>	<del>3 years</del>
<del>[Name]</del>	<del>Hollen [Address]</del>	<del><i>P. Williams</i></del>		
Evan Nebblet	3818 Fernhill Ave Baltimore, MD 21215	<i>E. Nebblet</i>	2/1994	10 years
<del>Dhanda Parker</del>	<del>1534 Barrett R Gwyn Oak MD 21207</del>	<del>_____</del>	<del>5/1956</del>	<del>4 years</del>

Board of Liquor License Commissioners for the City of Baltimore  
1 North Charles Street, Suite 1500, Baltimore, Maryland 21201  
Phone: 410-396-4377 Fax: 410-396-4382

Please note that this is a public document and upon request will be provided to the general members of the public.

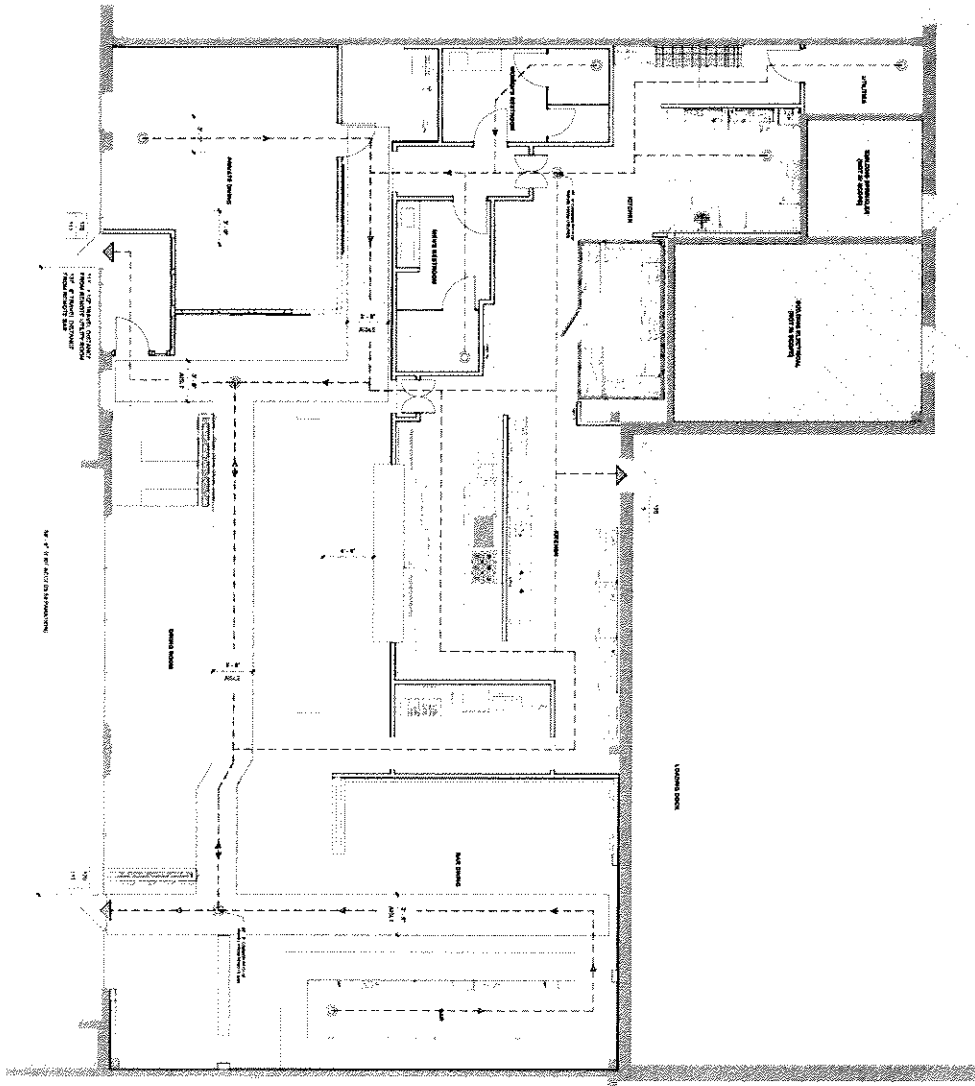

**DOCUMENTS & REVIEWS**

NO.	DATE	DESCRIPTION	BY	FOR
1	01/15/11	ISSUED FOR PERMIT	J. H. HARRIS	OWNER
2	01/15/11	ISSUED FOR PERMIT	J. H. HARRIS	OWNER

**REVISIONS**

NO.	DATE	DESCRIPTION
1	01/15/11	ISSUED FOR PERMIT
2	01/15/11	ISSUED FOR PERMIT

**REVISIONS**

NO.	DATE	DESCRIPTION
1	01/15/11	ISSUED FOR PERMIT
2	01/15/11	ISSUED FOR PERMIT

**REVISIONS**

NO.	DATE	DESCRIPTION
1	01/15/11	ISSUED FOR PERMIT
2	01/15/11	ISSUED FOR PERMIT

**REVISIONS**

NO.	DATE	DESCRIPTION
1	01/15/11	ISSUED FOR PERMIT
2	01/15/11	ISSUED FOR PERMIT

**REVISIONS**

NO.	DATE	DESCRIPTION
1	01/15/11	ISSUED FOR PERMIT
2	01/15/11	ISSUED FOR PERMIT

**REVISIONS**

NO.	DATE	DESCRIPTION
1	01/15/11	ISSUED FOR PERMIT
2	01/15/11	ISSUED FOR PERMIT

**REVISIONS**

NO.	DATE	DESCRIPTION
1	01/15/11	ISSUED FOR PERMIT
2	01/15/11	ISSUED FOR PERMIT

**REVISIONS**

NO.	DATE	DESCRIPTION
1	01/15/11	ISSUED FOR PERMIT
2	01/15/11	ISSUED FOR PERMIT

**REVISIONS**

NO.	DATE	DESCRIPTION
1	01/15/11	ISSUED FOR PERMIT
2	01/15/11	ISSUED FOR PERMIT

**REVISIONS**

NO.	DATE	DESCRIPTION
1	01/15/11	ISSUED FOR PERMIT
2	01/15/11	ISSUED FOR PERMIT

**REVISIONS**

NO.	DATE	DESCRIPTION
1	01/15/11	ISSUED FOR PERMIT
2	01/15/11	ISSUED FOR PERMIT

**REVISIONS**

NO.	DATE	DESCRIPTION
1	01/15/11	ISSUED FOR PERMIT
2	01/15/11	ISSUED FOR PERMIT

**REVISIONS**

NO.	DATE	DESCRIPTION
1	01/15/11	ISSUED FOR PERMIT
2	01/15/11	ISSUED FOR PERMIT

**REVISIONS**

NO.	DATE	DESCRIPTION
1	01/15/11	ISSUED FOR PERMIT
2	01/15/11	ISSUED FOR PERMIT

**REVISIONS**

NO.	DATE	DESCRIPTION
1	01/15/11	ISSUED FOR PERMIT
2	01/15/11	ISSUED FOR PERMIT

**REVISIONS**

NO.	DATE	DESCRIPTION
1	01/15/11	ISSUED FOR PERMIT
2	01/15/11	ISSUED FOR PERMIT

**REVISIONS**

NO.	DATE	DESCRIPTION
1	01/15/11	ISSUED FOR PERMIT
2	01/15/11	ISSUED FOR PERMIT

**REVISIONS**

NO.	DATE	DESCRIPTION
1	01/15/11	ISSUED FOR PERMIT
2	01/15/11	ISSUED FOR PERMIT



**PROFESSIONAL SEAL**  
 J. H. HARRIS  
 ARCHITECT  
 1515 N. WOODBERRY RD.  
 WASHINGTON, DC 20002

**REVISIONS**

NO.	DATE	DESCRIPTION
1	01/15/11	ISSUED FOR PERMIT
2	01/15/11	ISSUED FOR PERMIT

**ISSUANCE**

NO.	DATE	DESCRIPTION
1	01/15/11	ISSUED FOR PERMIT
2	01/15/11	ISSUED FOR PERMIT

**MISS TOYA'S - NORTHWOOD COMMONS**  
 1515 N. WOODBERRY RD.  
 WASHINGTON, DC 20002  
 Project # 1727 Date 01/15/11  
 Scale 1/4" = 1'-0"  
**CODE ANALYSIS AND EGRESS PLAN**

**0001**

## Small Plates

<b>Creole Spinach Dip</b>	<b>\$13</b>	<b>Creole Wings</b>	<b>\$16</b>
Creamy Spinach & Three Cheese Dip Served With Tortilla Chips. +Add Crab \$6		Marinated In Creole Spices. Then Deep Fried Or Grilled. Choice Of Hot Honey Bourbon Glaze, Cajun Buffalo Or Naked.	
<b>Fried Green Tomatoes</b>	<b>\$13</b>	<b>New Orleans BBQ Shrimp</b>	<b>\$16</b>
Battered Cornmeal Green Tomatoes Served With A Creole Aioli. Add Crab +6		Garlic Flavored Creamy Sautéed Shrimp Served With Garlic Toasted Bread.	
<b>Bayou Rolls</b>	<b>\$15</b>	<b>Voodoo Shrimp</b>	<b>\$16</b>
Diced Chicken Peppers And Cheese Wrapped In A Crispy Egg Roll Wrapper Served With A Remoulade Aioli.		Homemade Buffalo Shrimp With Jalapeño And Blue Cheese Crumble.	
<b>Spiced Devil Eggs With Crab Meat</b>	<b>\$16</b>	<b>Garlic Mussels</b>	<b>\$18</b>
Sweet Relish, Creole Spice Eggs Topped With Fresh Jumbo Lump Crab Meat.		Fresh Steamed Mussels Cooked With White Wine In A Creole Seafood Broth.	
<b>Cajun Fried Calamari</b>	<b>\$22</b>	<b>Surf &amp; Turf Rolls</b>	<b>\$24</b>
Deep Fried Calamari Served With Bang Bang Sauce.		Sautéed Steak Jambalaya Spiced Onions Peppers Cheese Jumbo Lump Crab Meat In A Egg Roll Served With Sweet Chili Sauce.	

## Soup & Salads

Add Chicken \$8 - Add Shrimp \$10 - Add Salmon \$13 - Add Crab Cake \$20 - Add Lobster \$20

House Salad \$14

Bed Of Spring Mix, Cherry Tomatoes, Red Onions, Avocado And Shredded Carrots.

Caesar Salad \$13

Romaine Lettuce Shaved Parmesan Black Pepper.

Summer Vegan Salad \$14

Spring Mix With Strawberries, And Roasted Almonds.

Cup Of Gumbo \$15

Andouille Sausage, Shrimp And Chicken Simmered In A Cajun Style Broth, Topped With Scallion Rice.

## Raw Bar & Oyster Menu

Oysters On The Half Shell \$3

Minimum Of 6

Rockefeller Oysters \$18

Chargrilled Oysters Topped With Cheesy Creamy Spinach.

Charbroil Oysters \$17

Freshly Shucked And Broiled Topped With Herb Lemon Butter And Parmesan Cheese.

# Sandwiches & Burgers

Miss Toyas Chicken  
Sandwich \$18

Fried Chicken Sandwich Honey Garlic  
Butter, Sweet Cheese Served With Fries.

Downtown Loaded Burger \$18

Fresh Ground Beef, Onion Ring, Smoke  
Swiss Cheese, Mambo Sauce Served With  
Fries.

Seafood Po Boy \$25

Choice Fried Or Blackened Catfish &  
Shrimp Dressed Po Boy With Remoulade  
Sauce Served With Fries.

# Entrées

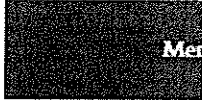

<b>Bayou Pasta</b>	<b>\$25</b>	<b>Pittsburgh Ribeye</b>	<b>\$55</b>
Blackened Chicken Topped Over Linguine Pasta.		USDA Ribeye Cooked Pittsburgh Style Served With Garlic Compound Butter With Two Sides.	
<b>Loaded Creole Pasta</b>	<b>\$55</b>	<b>Creole Spiced Lamb</b>	<b>\$45</b>
Shrimp, Lobster, Crab Meat, And A Crableg Over A Bed Of Creamy Cajun Fettuccine Pasta.		Rack Of Lambs Seasoned To Perfection Demi Glaze Sauce Served With Two Sides. Try Stuffed With Fresh Crab Meat +\$10	
<b>Catfish And Grits</b>	<b>\$30</b>	<b>Pork Chops</b>	<b>\$35</b>
Fresh Wild Caught Catfish Blackened Or Fried, Served Over A Bed Of White Cheddar Smoke Grits, Topped With A Jambalaya Creole Cream Sauce. Add Crab Meat +\$10		Deep Fried Golden Or Grilled Pork Chops Topped With A Brown Gravy Served With Two Sides.	
<b>Salmon</b>	<b>\$30</b>	<b>Beef Short Ribs</b>	<b>\$50</b>
Pan Seared Salmon Served With Choice Of Two Sides. Add Stuffed Crab Meat +\$10		Beef Short Ribs Jambalaya Sauce Served Over Spinach Choice Of Mashed Potatoes Or Creamy Grits.	
<b>Crab Cakes   Market Price</b>		<b>Loaded Gumbo</b>	<b>\$38</b>
Panko Crusted Jumbo Lump Crab Cake Served With A Grain Mustard Remoulade Aioli.		Andouille Sausage, Shrimp, Crableg And Chicken Slow Cooked In A Creole Style And Served With Scallion Rice.	
<b>Whole Roasted Cajun Snapper   Market Price</b>		<b>Jambalaya</b>	<b>\$30</b>
Fresh Caught Red Tail Snapper Seasoned With Creole Spices. Choice Of Fried Or Char-Grilled Served With Fresh Veggies And A Jambalaya Sauce		Shrimp Chicken Sausage Tomato Stew Sauce Over Choice Of Rice Or Spicy Creamy Linguine Fettuccine.	
<b>Creole Herb Chicken</b>	<b>\$30</b>	<b>Shrimp And Grits</b>	<b>\$28</b>
Half Chicken Breast Creole Seasoned		Creole Garlic Shrimp Sauteed Over A Bed Of Cheesy Grits. +Add Meat Crab \$10	

---

# Kid's Menu

Available for kids until 12 years old

Kids Alfredo	\$12
Kids Chicken Tenders	\$12
Kids Shrimp Basket	\$12

# Sides

Four Cheese Mac And Cheese	\$9	Crab Fries	\$18
Seafood Mac And Cheese	\$15	Lobster Mashed Potatoes	\$15
Lemon Herb Grilled Broccoli	\$11	Mashed Potatoes	\$9
Asparagus	\$9	Sweet Potato Casserole	\$9
Sautéed Spinach With Parmesan Shaving	\$9	Cajun Fries	\$7
Seafood Fried Rice	\$15	Honey Cornbread	\$7
Fried Rice Crab & Shrimp			
Rice & Beans	\$9		



# Desserts

<b>White Chocolate Vanilla Bean Bread Pudding</b>	<b>\$12</b>	<b>Key Lime Pie</b>	<b>\$12</b>
Served With Ice Cream.		<b>Banana Pudding Cheesecake</b>	<b>\$15</b>
<b>Strawberry Biscuits</b>	<b>\$12</b>	Fresh Cheesecake Topped With Banana Pudding Wafers And Carmel Sauce	
<b>Beignet</b>	<b>\$8</b>		
<b>Beignet Sundae</b>	<b>\$10</b>		
Served With Ice Cream.			

## Daily Brunch

11am - 3pm

<b>Chicken Waffles</b>	<b>\$25</b>	<b>Lamb Chops Eggs</b>	<b>\$45</b>
<b>French Toast Breakfast</b>	<b>\$35</b>	Martinated Lamb Chops With Eggs Cooked Your Way	
Served With French Toast, Eggs Cooked Your Way, And A Choice Of Bacon, Sausage, Gouda Grils, Or Fried Potatoes		<b>Crab Cake Benny</b>	<b>\$30</b>
<b>Steak And Eggs</b>	<b>\$40</b>	Jumbo Lump Crab Cake Over English Muffin, With Poached Eggs And A Creamy Creole Hollandaise Sauce. Optional Request: Sub For Scrambled Eggs (Ask For Cheese) And Optional Request Sauce On Side	
Spicy Creole Ribeye Steak With Eggs Cooked Your Way		<b>Seafood Omelette</b>	<b>\$25</b>
		Omelette Topped With Shrimp & Crab Meat Served With A Tomato Creole Sauce	

# Specialty Cocktails

<b>Miss Toya's Hurricane</b>	<b>\$18</b>	<b>Lady Voodoo</b>	<b>\$22</b>
Bacardi Rum, Pineapple Juice, Orange Juice, Passionfruit, Pomegranate Juice.		CASAMIGOS Blanco, Fresh Blood Orange, House-Made Sour Mix, Dry Ice.	
<b>Miskiri VI</b>	<b>\$22</b>	<b>Becky's Sangria</b>	<b>\$22</b>
CASAMIGOS Reposado, Grand Marnier, Raspberries, Lemon Juice, Agave.		Red Wine Blend, Hennessy, Tropical Fruit Juices, Frozen Popsicle.	
<b>Blackberry French</b>	<b>\$18</b>	<b>Nola Drop</b>	<b>\$18</b>
Empress 1908 Gin, Champagne, Blackberries White Flower.		Tito's Vodka, Orange Liqueur, Fresh Lemon Juice, Agave.	
<b>Creole Island</b>	<b>\$20</b>	<b>Last Sazerac</b>	<b>\$18</b>
Grand Mariner, Hennessy, Orange Juice, House Punch.		SAGAMORE SPIRIT RYE, Absinthe, Peychaud's Bitters, Sugar Cubes, Lemon.	
<b>Louisiana Tea</b>	<b>\$19</b>	<b>Peach Please</b>	<b>\$18</b>
Uncle Nearest 1856, Honey Mint Simple Syrup, Lemonade, Soda.		Tito's Handmade Vodka, Peach Nectar, Orange Juice, Champagne.	

# Happy Hour

3pm to 6pm

<b>Miss Toya's Hurricane</b>	<b>\$10</b>
Bacardi Rum, Pineapple Juice, Orange Juice, Passionfruit, Pomegranate Juice.	
<b>Margaritas</b>	<b>\$10</b>
<b>Strawberry Hennessy</b>	<b>\$10</b>
<b>Nola Drop</b>	<b>\$10</b>
Tito's Vodka, Orange Liqueur, Fresh Lemon Juice, Agave.	
<b>Whiskey Sour</b>	<b>\$10</b>
<b>Piña Passion</b>	<b>\$10</b>

# MISS TOYA'S CREOLE HOUSE NORTHWOOD LLC: W23100902

**Department ID Number:**

W23100902

**Business Name:**

MISS TOYA'S CREOLE HOUSE NORTHWOOD LLC

**Principal Office:** 

14916 RUNNING HORSE PLACE

BOWIE MD 20715

**Resident Agent:** 

ANDREW J OPIOLA

20 S. CHARLES STREET

SUITE 1200

BALTIMORE MD 21201

**Status:**

ACTIVE

**Good Standing:**

THIS BUSINESS IS IN GOOD STANDING

**Business Type:**

DOMESTIC LLC

**Business Code:**

20 ENTITIES OTHER THAN CORPORATIONS

**Date of Formation/ Registration:**

07/07/2022

**State of Formation:**

MD

**Stock Status:**

N/A

**Close Status:**

N/A

PROPOSED LOCATION: 1500 Havenwood Rd aka 1532-1534 Havenwood Rd,  
Suite B-170

### MAP SUMMARY (RECAPITULATION)

TOTAL ESTABLISHMENTS IN MAP AREA 0

"A" BEER & WINE \_\_\_\_\_

"B" BEER & WINE \_\_\_\_\_

"C" BEER & WINE \_\_\_\_\_

"D" BEER & WINE \_\_\_\_\_

"A" BEER, WINE & LIQUOR \_\_\_\_\_

"A-2" BEER, WINE & LIQUOR \_\_\_\_\_

"B" BEER, WINE & LIQUOR \_\_\_\_\_

"C" BEER, WINE & LIQUOR \_\_\_\_\_

"D" BEER, WINE & LIQUOR \_\_\_\_\_

"BD7" BEER, WINE & LIQUOR \_\_\_\_\_

ARENA \_\_\_\_\_

HOTEL/MOTEL \_\_\_\_\_

RACING \_\_\_\_\_

PREPARED BY: Chase DATE: 6/14/23

# 1500 Havenwood Rd k/a 1532-34 Havenwood Rd, Suite B-170

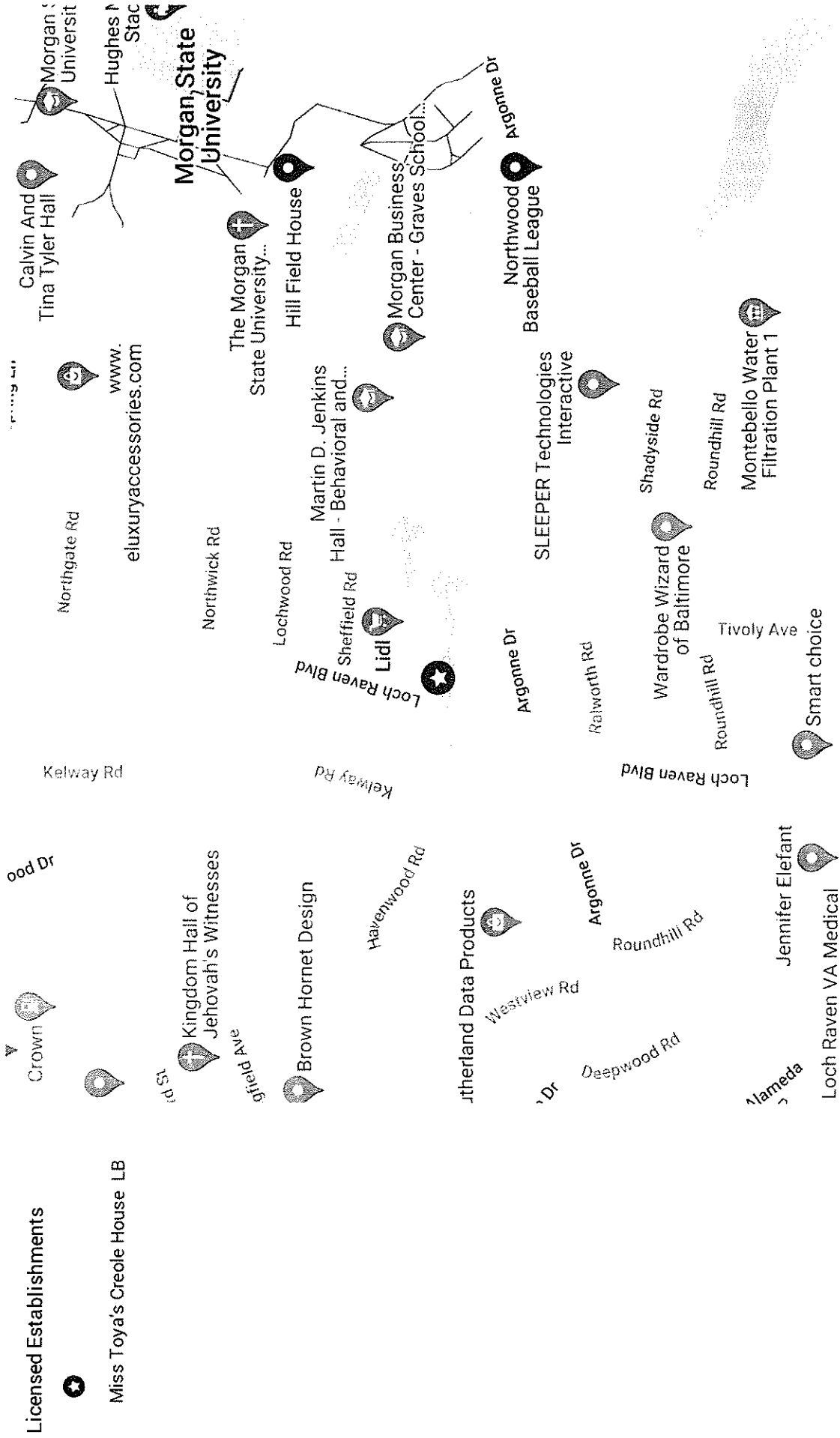

# Board of Liquor License Commissioners

For Baltimore City  
1 North Charles Street, 15th Floor  
Baltimore, Maryland, 21201

## INSPECTORS REPORT - TRANSFERS/NEW APPLICATIONS

Licensee Information (Trade Name):	Miss Toya's Creole House
Corporation Name:	Miss Toya's Creole House Northwood, LLC
Location Address:	1500 Havenwood Rd k/a 1532-34 Havenwood Rd, Suite B-170
License Type:	Class "B" Beer, Wine and Liquor ▼
Is the establishment open and operating in a safe and sanitary manner? (If not open, not in comments - CLOSED or NOT OPERATING)	No ▼
Is the location within 300 feet of Church and/or School?	No ▼
Date Posted?	6/9/2023 <input type="checkbox"/>
Estimated Date of Removal?	6/19/2023 <input type="checkbox"/>
Are there any other licensed establishments within a two block radius?	Yes ▼

Other licensed locations - Describe/Note:

Please see maps for additional locations

Comments and Follow-up Items(s) (please note any issues or concerns about the location):

Filed application for New class "B" license with outdoor table service, and live entertainment which includes jazz trio, and Dj for special occasion

Insert Photo of Sign and location:

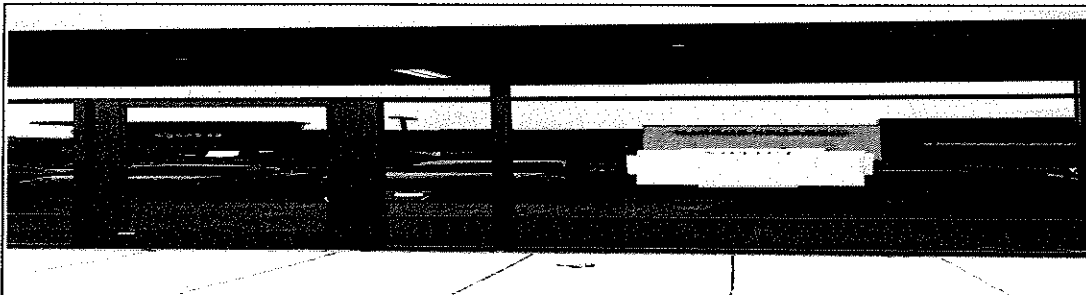

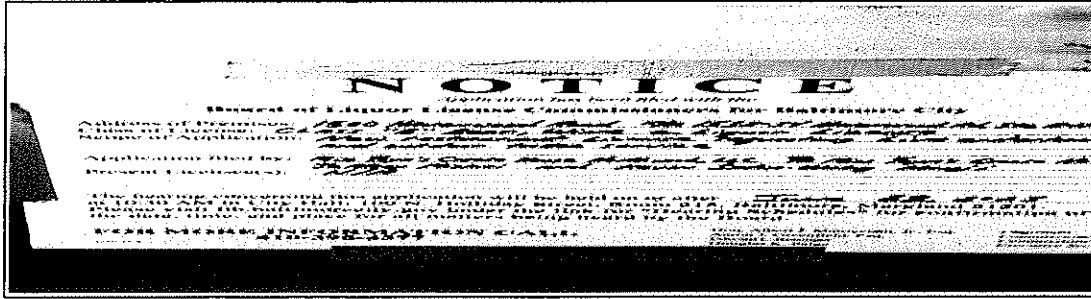

Attach Additional Photos

Inspector Name	Date and Time
<input type="text" value="i:0#w/baltimore\terri.chase"/>	<input type="text" value="6/14/2023"/> <input type="text" value="1:03:55 PM"/>
Name of Licensee (if present)	
<input type="text"/>	
<input type="button" value="Approve"/> <input type="button" value="Disapprove"/>	



# Board of Liquor License Commissioners

For Baltimore City  
1 North Charles Street, 15th Floor  
Baltimore, Maryland, 21201

## POSTING SIGNS REPORT

*Applicant(s) Name:* Jeffrey Miskiri; Kevin Satia-Wat

*Address of Premises:* 1500 Havenwood Rd k/a 1532-34 Havenwood Rd, suite B-170

*Inspector:* i:0#w/baltimore\terri.chase

*Date Posted:* 6/9/2023

*Time Posted:* 2:00 PM

*Date Rechecked:* 6/19/2023

*Time Rechecked:* 3:00 PM

*Manager or Owner when sign posted:* N/A

*Summary on location of sign posted:*

The sign is posted on the front door.

*Summary on location of sign rechecked:*

The sign is still posted on the front door.

*Insert Photo of Sign and location:*

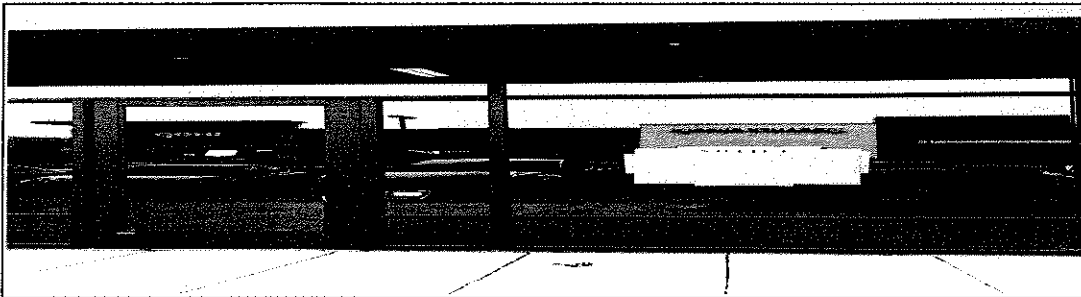

**NOTICE**

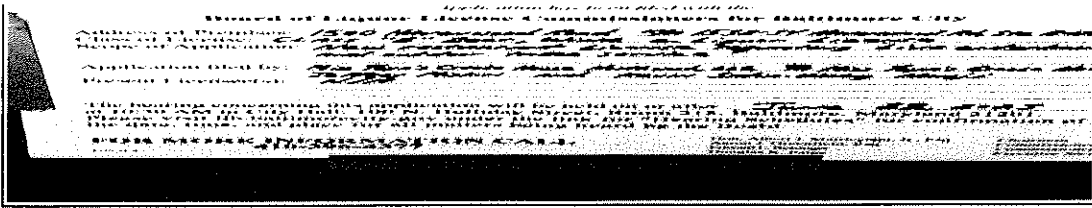

Attach Additional Photos

Approve

Disapprove

# NOTICE

Application has been filed with the

## Board of Liquor License Commissioners for Baltimore City

Address of Premises: 1500 HAVENWOOD ROAD VIA 1532-34 HAVENWOOD RD. STE B-17A  
Class of License: CLASS "B" BEER, WINE & LIQUOR LICENSE  
Scope of Application: NEW RESTAURANT LICENSE REQUESTING LIVE ENTERTAINMENT AND OUTDOOR TABLE SERVICE

Application filed by: MISS TOYA'S CREOLE HOUSE NORTHWOOD, LLC TA MISS TOYA'S CREOLE HO.  
TEFFREY MISTIKI AND KEVIN SATIA-WORTHY NAWJI  
Present Licensee(s): N/A

The hearing concerning this application will be held on or after JUNE 22, 2023 at 10:30 AM in City Hall; 100 N. Holliday Street, Room 215, Baltimore, Maryland 21201. Please visit [lb.baltimorecity.gov](http://lb.baltimorecity.gov) under the link for "Hearing Schedules" for confirmation of the date, time, and place for all matters being heard by the Board.

**FOR MORE INFORMATION CALL  
410-396-4377**

1210832-4

Hon. Albert J. Matricciani, Jr., Esq. *Chairman*  
Aaron J. Greenfield, Esq. *Commissioner*  
Edward L. Reisinger *Commissioner*  
Douglas K. Paige *Executive Secy*

## Maggie Giordano

---

**From:** no\_reply@cels.baltimorehousing.org  
**Sent:** Monday, March 6, 2023 3:36 PM  
**To:** Maggie Giordano  
**Cc:** epermits.msg@baltimorecity.gov  
**Subject:** City of Baltimore - ePermits - Message Board - USE2023-51321



ePermits Online Message Board.

This is a post from Baltimore City.

[Please click here to review.](#)

If you have any questions, please call the Permit Office: 443-984-1809.

Permit number: USE2023-51321

Project Name: 1500 HAVENWOOD ROAD

Address: 1500 HAVENWOOD RD B-170

Sent by:

Category: Question About Permit Application

Subject: USE

Message: Your Use & Occupancy application requires the following inspection(s): Fire Dept. (311 or 443-263-2220), Health Dept. (410-396-4544 or 4424), and Building Inspections (schedule online by logging into your account and selecting "Inspection Scheduler" or through the QuickTrac system 443-984-2776, use inspection code 5404). Note: If multiple inspections are required Building Inspection must be your last inspection.

Account: [mgiordano@rosenbergmartin.com](mailto:mgiordano@rosenbergmartin.com)

[Back](#)   [Logout](#)

**Project Name:1500 HAVENWOOD ROAD**

*Guest Access*

TO USE THE PREMISES KNOWN AS 1532-1534 HAVENWOOD ROAD, SUITE E-170, AS A RESTAURANT WITH OUTDOOR TABLE SERVICE AND LIVE ENTERTAINMENT