

February 9, 2023

Applicant(s): Kathryn D. Barrett and Kristopher Beck
PHOTA-FD Baltimore, LLC, T/a SpringHill Suites
400 W. Fayette Street 21201

Class: "B" Beer, Wine & Liquor Hotel-Motel License

Application for a new Class "B" Beer, Wine and Liquor Hotel-Motel license; Board to rehear matter concerning an issue identified during issuance process.

(a) **Applicant(s) Information:** (1) Kathryn D. Barrett was born in Houston, TX in February of 1985. She lives in Baltimore, MD; and (2) Kristopher Beck was born in Seattle, WA in October of 1960. He lives in Fairfax, VA. (see attached)

(b) **Ownership Breakdown:** (1) Kathryn D. Barrett (0%); and (2) Kristopher Beck (0%).(see attached).

(c) **Purchase Price of Business:** N/a

(d) **Qualified Voters:** Lee Gerstein, Natalie Moore, and Ryan Haynes are qualified Baltimore City voters.

(e) **Zoning:** Applicant has applied for a USE permit, for the use of the premise basement and first floor as a hotel.

(f) **Corporate Standing:** PHOTA-FD Baltimore, LLC is a MD LLC and as of 1/26/2023 is active and in good standing.

(g) **Posting Report:** The location was posted on 9/19/2022 and checked on 9/28/2022. This meets the 10-day rule. There are 6 licensed liquor establishments in the 4x4 area: "B" BWL- 2; and "BD7" BWL- 4.

(h) **Timeline:** N/A

(i) **Letters of Support/Opposition:** At this time the Board has no letter(s) of opposition or support.

In considering this request, under the provisions of Alcohol Beverages Article 4-210(A) the Board must consider the following factors: 1. The public need and desire for the license; 2. The number and location of existing license holders; 3. The potential effect on existing license holders of the license for which application is made; 4. The potential commonality or uniqueness of the services and products to be offered by the business of the applicant; 5. The impact of the license for which application is made on the health, safety, and welfare of the community, including issues relating to crime, traffic conditions, parking, or convenience; and 6. Any other factor that the local licensing Board considers necessary.

Board's Decision:

2022 Application for Alcoholic Beverages License Board of Liquor License Commissioners for Baltimore City

NEW/TRANSFER/EXPANSION/AMENDMENT(S) APPLICATION FEE - \$600.00

INDICATE TYPE OF LICENSE APPLICATION: TRANSFER NEW EXPANSION OF PREMISES AMENDMENT(S)

EXPLANATION OF REQUEST: _____ CLASS TYPE: B(OWL)

Please select one option and fill out the requested information

A) NEW LICENSE REQUEST: ADDRESS OF PROPOSED LOCATION: 400 W. Fayette St., Baltimore, MD 21201

B) TRANSFER OF OWNERSHIP ONLY: ADDRESS OF CURRENT LICENSE: _____

C) TRANSFER OF OWNERSHIP AND LOCATION: CURRENT ADDRESS OF LICENSED LOCATION: _____
 TRANSFER OF OWNERSHIP AND LOCATION: ADDRESS OF PROPOSED RELOCATION: _____

D) AMENDMENT OR EXPANSION REQUEST: ADDRESS OF THE LOCATION: _____

CORPORATE/LLC/LLP/PARTNERSHIP NAME: PHOTA-FD Baltimore, LLC TRADE NAME: SpringHill Suites

BUSINESS PHONE NUMBER: 410-685-1095 BUSINESS EMAIL ADDRESS: dpowell@peachtreehotelgroup.com

ATTORNEY FOR THE APPLICANT: Leanne Schrecengost ADDRESS: 102 W. Pennsylvania Ave, #600, Towson, MD 21204 PHONE: 410-823-1800

Part of Premises Used (Note: floors and areas for storage): Entire 12-story hotel. Outdoor Table Service Provided? Yes No Delivery of alcohol? Yes No
 Live Entertainment provided? Yes No What Kind (Ex. DJ Band, Etc.)? _____ Off Premise Catering of Food and Alcohol? Yes No
 Zoning Receipt or Current Certificate of Occupancy Permit attached to Application? Yes No Estimated Seating Capacity: 238

Please note that as per Alc. Bev. Art. 8 12-1407(A)(2), an application for the issuance or transfer, is not complete unless the applicant has obtained approval and/or verification from the Baltimore Municipal Zoning Appeals (BMZA)

1. Applicant A

Kethryn D. Barrett

(Full name) _____ (Telephone no.) _____ E-mail (Required) _____
 1007 E. Lake Avenue _____ Baltimore MD 21212 9.5 years
 (Residence) Street _____ City State Zip Code _____ (period of residency in Baltimore City)
 02/1985 _____ Female _____ Houston, TX
 (Month/Year of Birth) _____ (Sex: Male or Female) _____ (Place of Birth)
 Check: Yes No Are you currently a resident of the City of Baltimore?

2. Applicant B

Kristopher Beck

(Full name) _____ (Telephone no.) _____ E-mail (Required) _____
 12454 Blissful Valley _____ Fairfax VA 22033 n/a
 (Residence) Street _____ City State Zip Code _____ (period of residency in Baltimore City)
 10/80 _____ Male _____ Seattle, WA
 (Month/Year of Birth) _____ (Sex: Male or Female) _____ (Place of Birth)
 Check: Yes No Are you currently a resident of the City of Baltimore?

3. Applicant C

n/a

(Full name) _____ (Telephone no.) _____ E-mail (Required) _____
 (Residence) Street _____ City State Zip Code _____ (period of residency in Baltimore City)
 (Month/Year of Birth) _____ (Sex: Male or Female) _____ (Place of Birth)
 Check: Yes No Are you currently a resident of the City of Baltimore?

RECEIVED: BLLC
AUG 25 2022 PM 2:34

1. Has the applicant(s) been adjudged guilty of a felony in the State of Maryland or any other? Yes No - If yes, indicate applicant and explain.
Applicant A B C

2. Has the applicant(s) been adjudged guilty of violating the laws governing the sale of any alcoholic beverage or for gambling in any State, including Maryland? Yes No - If yes, mark applicant and provide explanation in adjacent space provided.
Applicant A B C

3. State whether the applicant(s) has ever been adjudged guilty of any offense against the laws of the State of Maryland, any other State within the United States, or against the United States (Federal Crime)? Yes No - If yes, mark applicant and explain.
Applicant A B C

4. Has the applicant(s) ever had a license for the sale of alcoholic beverages in the State of Maryland? Yes No If yes, mark applicant and explain (address of location, dates that the applicant was a licensee, and the trade name).
Applicant A B C

See attached.

5. Has the applicant(s) ever had a liquor license suspended or revoked? Yes No If yes, mark applicant and explain.
Applicant A B C

6. Does the applicant(s) have a financial interest in any other alcoholic beverage business or business for which an alcoholic beverage license has been applied for, granted, and issued? Yes No If yes, mark applicant and explain (address of location and trade name).
Applicant A B C

See attached.

7. Do the spouses or dependent children of any of the applicant(s) have a financial interest in any other alcoholic beverages license or business in Baltimore City or any other jurisdiction in the State of Maryland? Yes No If yes, mark applicant and explain (address of location and trade name).
Applicant A B C

8. Are you financially interested in any other alcoholic beverages license applied, granted or issued? Yes No If yes, please explain.
Applicant A B C

See attached.

9. Is the licensed premise currently open and operating? Yes No If no, then provide date of last day of operation of the establishment.

10. Do any of the applicant(s) - personally or through an entity - have any indebtedness or other financial obligations to any manufacturer, brewer, distiller, or wholesaler at the time of making this application? Yes No If yes, please explain. If yes, please provide information as to the applicant(s) indebted - personally or through an entity - the amount of the indebtedness, and the name of the manufacturer, brewer, distiller, or wholesaler?

Applicant A B C

SpringHill Suites Baltimore
400 W. Fayette Street
Baltimore, Maryland 21201

Supplement to Application

Question 4., Question 6. and Question 8.

Ms. Barrett is/was a licensee for the following licenses:

- Kona Grill, 1 E. Pratt Street, Suite 103, Baltimore, MD since October of 2020. **
- Hampton Inn Baltimore, 550 Washington Blvd, Baltimore, MD license since May of 2021.**
- CineBistro, 711 W. 40th Street, Baltimore, MD from 2017-2020.

Mr. Beck has been a licensee for Cambria Hotel & Suites, 1 Hellen Heneghan Way, Rockville, MD since December of 2021.**

The applicants have an interest in their respective licenses indicated by **.

II. Please list the following information for the Manager of the establishment to be licensed:

Name	Address	Phone	Email
JASON DAVIS	100 N. EUTAW ST. BALTIMORE, MD 21201	[REDACTED]	[REDACTED]

Applicants Applying as Business Entities - (Give name(s) and addresses - in Corporation list all officers (attach list if necessary) or in Limited Liability Company/Partnerships list all authorized persons.) *Please note that all licensees MUST have a FINANCIAL INTEREST in the license applied for as per Alc. Bev. Art. § 4-109 (a)(11). If necessary, please attach a list of the names and address of all outstanding stock holders who at the time of application own any stock of the corporation and the articles of incorporation, partnership agreement or articles of organization.* *See attached*

- 1) NAME: Kathryn D. Barrett ADDRESS: 1007 E. Lake Ave, Baltimore, MD 21212 TITLE: Auth. Person % OF STOCK HELD: n/a
- 2) NAME: Kristopher Beck ADDRESS: 12454 Blissful Valley, Fairfax, VA 22033 TITLE: Auth. Person % OF STOCK HELD: n/a
- 3) NAME: _____ ADDRESS: _____ TITLE: _____ % OF STOCK HELD: _____
- 4) NAME: _____ ADDRESS: _____ TITLE: _____ % OF STOCK HELD: _____

**Extract from Law: If any affidavit or oath required under the provisions of this Act shall contain any false statements, the offender shall be deemed guilty of perjury. And upon indictment and conviction thereof, shall be subject to penalties provided by Law for that crime.*

CERTIFICATE OF APPLICANTS: At least one applicant whose signature appears below certifies that he/she is a current resident of Baltimore City, Maryland at the time of filing of this application. Each of said applicants hereby certifies further that if the license applied for is granted, he/she will conform to all State and County laws and regulations relating to the sale of alcoholic beverages, as well as to the rules and regulations of the Board of License Commissioners for Baltimore City, and hereby grants permission to the State Comptroller, his duly authorized deputies, inspectors and clerks, The Board of License Commissioners for Baltimore City, its duly authorized agents and employees, and any peace officer of Baltimore City or the State of Maryland to inspect and search at any and all hours, without warrant, the premises and any and all parts thereof upon and in which said business is to be conducted. If license is issued, the applicants must ensure that at least one licensee remains a resident of Baltimore City throughout the duration of this license.

Kathryn D. Barrett
Signature of Applicant A

I hereby certify that on the _____ day of May, 2022 before me, the subscriber, a notary public of the State of Maryland in and for _____, personally appeared Kathryn D. Barrett the applicant(s) named in this application made oath in due form of law that the matter and facts contained in said application are true and correct. As witness, my hand and notarial seal.

Signature: _____ (Notary Seal) My Commission expires _____

Printed Name: _____

Kristopher Beck
Signature of Applicant B

I hereby certify that on the 7 day of June, 2022 before me, the subscriber, a notary public of the State of Georgia in and for city of Atlanta, personally appeared Kristopher Beck the applicant(s) named in this application made oath in due form of law that the matter and facts contained in said application are true and correct. As witness, my hand and notarial seal.

Signature: Alanna Uhde (Notary Seal) My Commission expires 7-19-24

Printed Name: Alanna Uhde

n/a

Signature of Applicant C

I hereby certify that on the _____ day of _____, 20____, before me, the subscriber, a notary public of the State of _____ in and for _____, personally appeared _____ the applicant(s) named in this application made oath in due form of law that the matter and facts contained in said application are true and correct. As witness, my hand and notarial seal.

Signature: _____ (Notary Seal) My Commission expires _____

Printed Name: _____

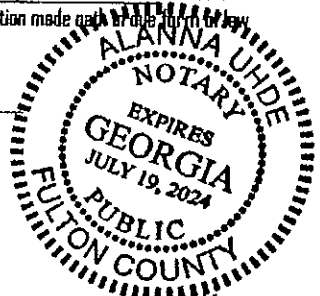

11. Please list the following information for the Manager of the establishment to be licensed:

Name	Address	Phone	Email

Applicants Applying as Business Entities - (Give name(s) and addresses - in Corporation list all officers (attach list if necessary) or in Limited Liability Company/Partnerships list all authorized persons.) Please note that all licensees MUST have a FINANCIAL INTEREST in the license applied for as per Alc. Bev. Art. § 4-109 (a)(11). If necessary, please attach a list of the names and address of all outstanding stock holders who at the time of application own any stock of the corporation and the articles of incorporation, partnership agreement or articles of organization.

- 1) NAME: Kathryn D. Barrett ADDRESS: 1007 E. Lake Ave, Baltimore, MD 21212 TITLE: Auth. Person % OF STOCK HELD: n/a
- 2) NAME: Kristopher Beck ADDRESS: 12454 Blissful Valley, Fairfax, VA 22033 TITLE: Auth. Person % OF STOCK HELD: n/a
- 3) NAME: _____ ADDRESS: _____ TITLE: _____ % OF STOCK HELD: _____
- 4) NAME: _____ ADDRESS: _____ TITLE: _____ % OF STOCK HELD: _____

*Extract from Law: If any affidavit or oath required under the provisions of this Act shall contain any false statements, the offender shall be deemed guilty of perjury. And upon indictment and conviction thereof, shall be subject to penalties provided by Law for that crime.

CERTIFICATE OF APPLICANTS: At least one applicant whose signature appears below certifies that he/she is a current resident of Baltimore City, Maryland at the time of filing of this application. Each of said applicants hereby certifies further that if the license applied for is granted, he/she will conform to all State and County laws and regulations relating to the sale of alcoholic beverages, as well as to the rules and regulations of the Board of License Commissioners for Baltimore City, and hereby grants permission to the State Comptroller, his duly authorized deputies, inspectors and clerks, The Board of License Commissioners for Baltimore City, its duly authorized agents and employees, and any peace officer of Baltimore City or the State of Maryland to inspect and search at any and all hours, without warrant, the premises and any and all parts thereof upon and in which said business is to be conducted. If license is issued, the applicants must ensure that at least one licensee remains a resident of Baltimore City throughout the duration of this license.

Kathryn Barrett

Kathryn D. Barrett

Signature of Applicant A

I hereby certify that on the 30th day of May, 2022 before me, the subscriber, a notary public of the State of Maryland in and for BALTIMORE CO. personally appeared Kathryn D. Barrett the applicant(s) named in this application made oath in due form of law that the matter and facts contained in said application are true and correct. As witness, my hand and notarial seal.

Signature: Laura A. Ferguson (Notary Seal) My Commission expires 4/5/2026

Printed Name: LAURA A. FERGUSON



Kristopher Beck

Signature of Applicant B

I hereby certify that on the _____ day of _____, 20____, before me, the subscriber, a notary public of the State of _____ in and for _____, personally appeared _____ the applicant(s) named in this application made oath in due form of law that the matter and facts contained in said application are true and correct. As witness, my hand and notarial seal.

Signature: _____ (Notary Seal) My Commission expires _____

Printed Name: _____

n/a

Signature of Applicant C

I hereby certify that on the _____ day of _____, 20____, before me, the subscriber, a notary public of the State of _____ in and for _____, personally appeared _____ the applicant(s) named in this application made oath in due form of law that the matter and facts contained in said application are true and correct. As witness, my hand and notarial seal.

Signature: _____ (Notary Seal) My Commission expires _____

Printed Name: _____

Name and Address of the owners of the premise/landlord: PHOTA-FD Baltimore, LLC/3500 Lenox Rd, #825, Atlanta, GA Phone Number: [REDACTED]

STATEMENT OF OWNER OF PREMISES REQUIRED IN CONNECTION WITH ALCOHOLIC BEVERAGES LAW OF MARYLAND

(I, WE) PHOTA-FD Baltimore, LLC HEREBY CERTIFY,

That (I am, we are) the owner(s) of the property located at 400 W. Fayette Street, Baltimore, City with a Zip Code of 21201, which is named in the present application made to the Board of Liquor License Commissioners of Baltimore City under the Alcoholic Beverage Laws of Maryland and assent to the granting of the license applied for, and hereby authorize the State Comptroller, his duly authorized deputies, inspectors and clerks, the Board of Liquor License Commissioners of Baltimore City, its duly authorized agents and employees, and any peace officer of the City of Baltimore and State of Maryland, to inspect and search, without warrant, the premises upon which the business is to be conducted, and any and all parts of the building in which said business is to be conducted, at any and all hours.

[Signature]
Signature of Owner of the Property

I hereby certify that on the 7 day of JUNE, 2022 before me, the subscriber, a notary public of the State of Georgia, in and for City of Atlanta, personally appeared Kevin Cadin the landlord/property owner named in this application made oath in due form of law that the matter and facts contained in said application are true and correct.

As witness, my hand and notarial seal.

Notary Signature: [Signature]

[Notary Seal] My Commission expires 7-19-24

Notary Printed Name: Alanna Unde

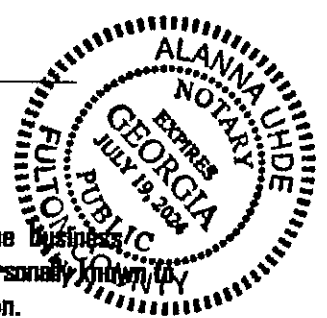

The following certificates must be signed by at least 3 persons.

We, the undersigned citizens, real estate owners and registered voters in the City of Baltimore in which the business covered by the present application is to be conducted. We certify that the qualifying applicant(s) is/are personally known to us and is a resident of Baltimore City and a resident of the State of Maryland at the time of this application.

Names	Address	Signature	DOB (Month/Year)	Length of time Acquainted with the Applicant(s)

Board of Liquor License Commissioners for the City of Baltimore
1 North Charles Street, Suite 1500, Baltimore, Maryland 21201
Phone: 410-396-4377 Fax: 410-396-4382

Please note that this is a public document and upon request will be provided to the general members of the public.

Name and Address of the owners of the premise/landlord: PHOTA-FD Baltimore, LLC/3500 Lenox Rd, #625, Atlanta, GA Phone Number: [REDACTED]

STATEMENT OF OWNER OF PREMISES REQUIRED IN CONNECTION WITH ALCOHOLIC BEVERAGES LAW OF MARYLAND

(I, WE) PHOTA-FD Baltimore, LLC HEREBY CERTIFY,
 That (I am, we are) the owner(s) of the property located at 400 W. Fayette Street, Baltimore, City with a Zip Code of 21201, which is named in the present application made to the Board of Liquor License Commissioners of Baltimore City under the Alcoholic Beverage Laws of Maryland and assent to the granting of the license applied for, and hereby authorize the State Comptroller, his duly authorized deputies, inspectors and clerks, the Board of Liquor License Commissioners of Baltimore City, its duly authorized agents and employees, and any peace officer of the City of Baltimore and State of Maryland, to inspect and search, without warrant, the premises upon which the business is to be conducted, and any and all parts of the building in which said business is to be conducted, at any and all hours.

 Signature of Owner of the Property

I hereby certify that on the _____ day of _____, 20____, before me, the subscriber, a notary public of the State of _____, in and for _____, personally appeared _____ the landlord/property owner named in this application made oath in due form of law that the matter and facts contained in said application are true and correct.

As witness, my hand and notarial seal.

Notary Signature: _____ [Notary Seal] My Commission expires _____

Notary Printed Name: _____

The following certificates must be signed by at least 3 persons.

We, the undersigned citizens, real estate owners and registered voters in the City of Baltimore in which the business covered by the present application is to be conducted. We certify that the qualifying applicant(s) is/are personally known to us and is a resident of Baltimore City and a resident of the State of Maryland at the time of this application.

Names	Address	Signature	DOB (Month/Year)	Length of time Acquainted with the Applicant(s)
Lee Gerstein	4415 Sedgwick Rd Baltimore MD 21210		12/84	20 years
Nathie Mious	4415 Sedgwick Baltimore 21210		2/82	7 years
Ryan Higgins	1607 E Lakes Ave Baltimore MD 21217		3/85	11 years

Board of Liquor License Commissioners for the City of Baltimore
 1 North Charles Street, Suite 1500, Baltimore, Maryland 21201
 Phone: 410-396-4377 Fax: 410-396-4382

Please note that this is a public document and upon request will be provided to the general members of the public.

100% OF THE FURNITURE AND FINISHES

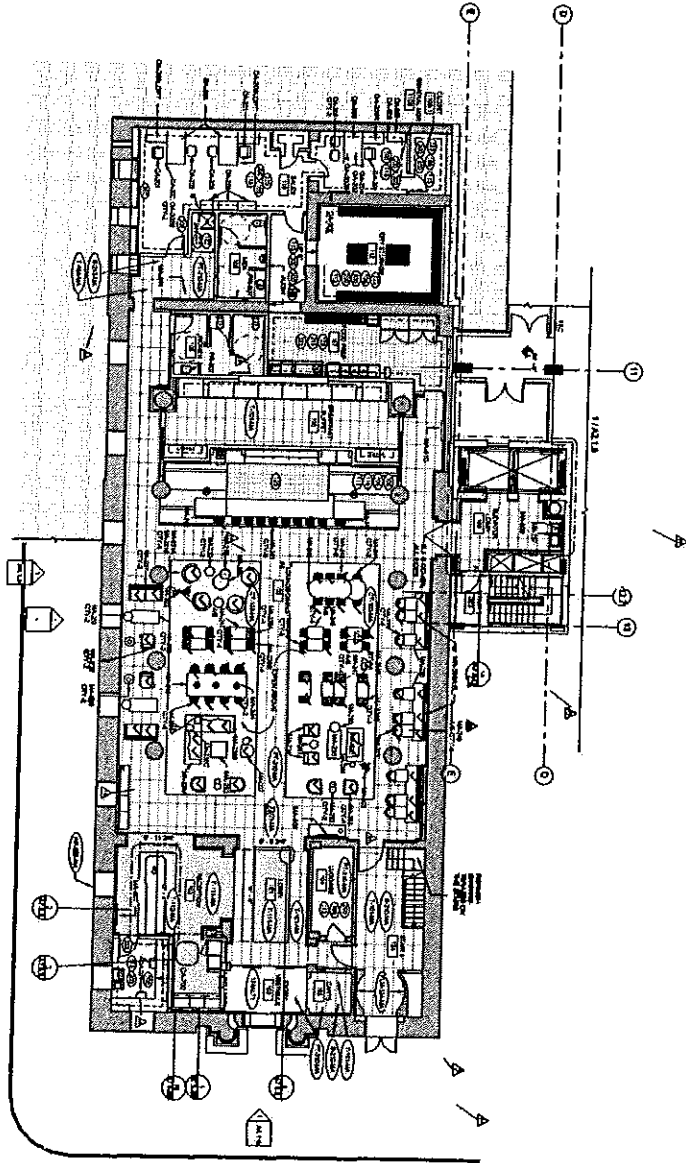

100% OF THE FURNITURE AND FINISHES

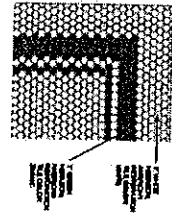

100% OF THE FURNITURE AND FINISHES

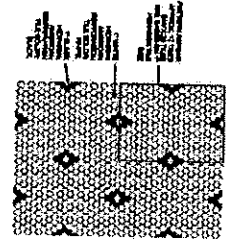

100% OF THE FURNITURE AND FINISHES

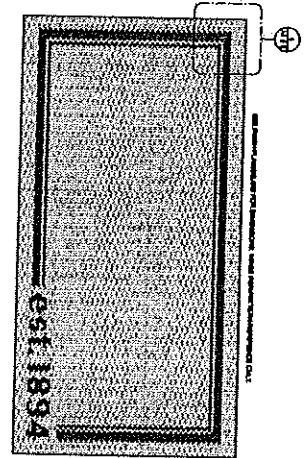

SPRINGHILL SUITES

400 West Fayette Street
Baltimore, MD 21201

MOSELEY ARCHITECTS

1404 NEEB AVENUE, BALTIMORE, MD 21220
PHONE: 410-639-4200 FAX: 410-639-4200
WWW.MOSELEYARCHITECTS.COM

SECTION 11.100000 - FURNITURE AND FINISHES

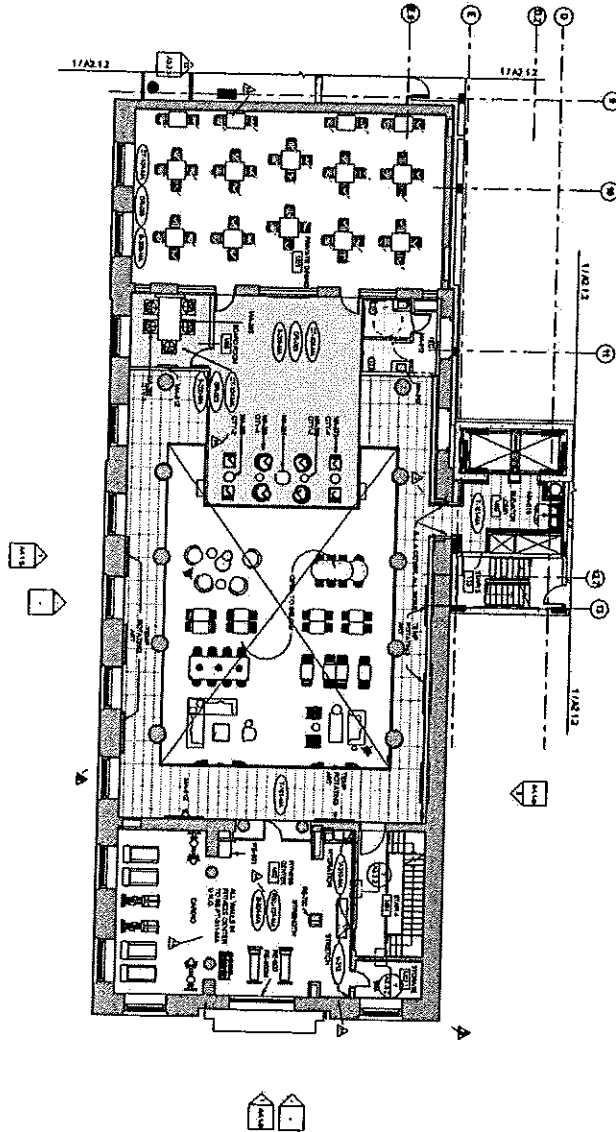

A7.5.4

MEZANINE -
FURNITURE AND
FINISH



SPRINGHILL SUITES

408 West Fayette Street
Baltimore, MD 21201

MOSELEYARCHITECTS

1044 KEY PROPERTY, BALTIMORE, MD 21204
PHONE: (410) 583-2200 FAX: (410) 528-6600
MOSELEYARCHITECTS.COM

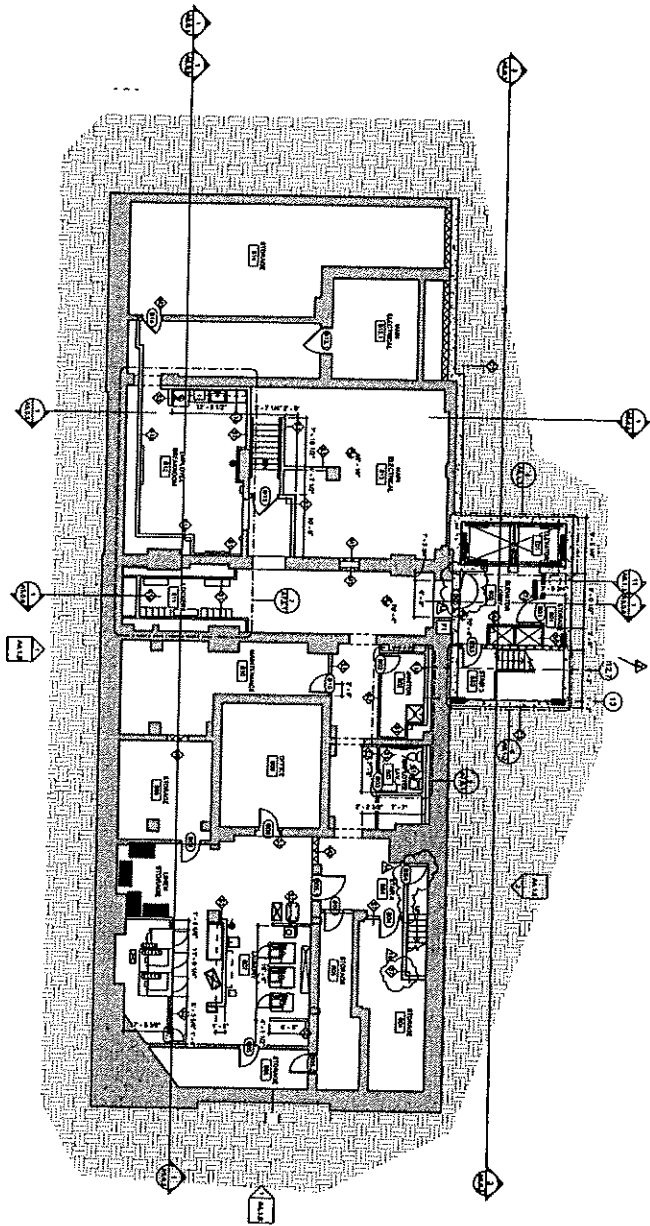

Basement Floor Plan - 10/10/06

- FLOOR PLAN GENERAL NOTES**
1. ALL WORK SHALL BE IN ACCORDANCE WITH THE 2001 INTERNATIONAL BUILDING CODE (IBC) AND THE 2001 INTERNATIONAL RESIDENTIAL CODE (IRC).
 2. ALL WORK SHALL BE IN ACCORDANCE WITH THE 2001 INTERNATIONAL MECHANICAL AND PLUMBING CODE (IMC) AND THE 2001 INTERNATIONAL PLUMBING AND HEATING CODE (IPHC).
 3. ALL WORK SHALL BE IN ACCORDANCE WITH THE 2001 INTERNATIONAL ELECTRICAL CODE (IEC) AND THE 2001 INTERNATIONAL WIRE AND CABLE CODE (IWCC).
 4. ALL WORK SHALL BE IN ACCORDANCE WITH THE 2001 INTERNATIONAL FIRE AND ALARM CODE (IFAC) AND THE 2001 INTERNATIONAL FIRE AND SAFETY CODE (IFSC).
 5. ALL WORK SHALL BE IN ACCORDANCE WITH THE 2001 INTERNATIONAL SMOKE CONTROL CODE (ISCC) AND THE 2001 INTERNATIONAL SMOKE AND GAS DETECTION CODE (ISGDC).
 6. ALL WORK SHALL BE IN ACCORDANCE WITH THE 2001 INTERNATIONAL SOUND AND VIBRATION CODE (ISVC) AND THE 2001 INTERNATIONAL SOUND AND VIBRATION CONTROL CODE (ISVCC).
 7. ALL WORK SHALL BE IN ACCORDANCE WITH THE 2001 INTERNATIONAL ENERGY EFFICIENCY CODE (IEEC) AND THE 2001 INTERNATIONAL ENERGY EFFICIENCY CONTROL CODE (IEECC).
 8. ALL WORK SHALL BE IN ACCORDANCE WITH THE 2001 INTERNATIONAL ACCESSIBILITY AND MOBILITY ACT (AMA) AND THE 2001 INTERNATIONAL ACCESSIBILITY AND MOBILITY CONTROL CODE (IAMCC).
 9. ALL WORK SHALL BE IN ACCORDANCE WITH THE 2001 INTERNATIONAL SAFETY AND HEALTH CODE (ISHC) AND THE 2001 INTERNATIONAL SAFETY AND HEALTH CONTROL CODE (ISHCC).
 10. ALL WORK SHALL BE IN ACCORDANCE WITH THE 2001 INTERNATIONAL ENVIRONMENTAL AND CLIMATE CHANGE CODE (IECCC) AND THE 2001 INTERNATIONAL ENVIRONMENTAL AND CLIMATE CHANGE CONTROL CODE (IECCC).

APARTMENTS 444

400 West Fayette Street
 Baltimore, MD 21201

MOSELEYARCHITECTS

100 WEST HENRIETTA, BALTIMORE, MD 21201
 PHONE: 410-528-4000 FAX: 410-528-4001
 WWW.MOSELEYARCHITECTS.COM

CONSTRUCTION DOCUMENTS

Project Name	APARTMENTS 444
Project Address	400 West Fayette Street, Baltimore, MD 21201
Client	[REDACTED]
Architect	MOSELEY ARCHITECTS
Engineer	[REDACTED]
Interior Designer	[REDACTED]
Contractor	[REDACTED]
Construction Manager	[REDACTED]
Permitting Authority	[REDACTED]
Construction Start Date	[REDACTED]
Construction End Date	[REDACTED]
Revision	10.04.06 AM

A2.2.1

BASEMENT FLOOR PLAN - HOTEL

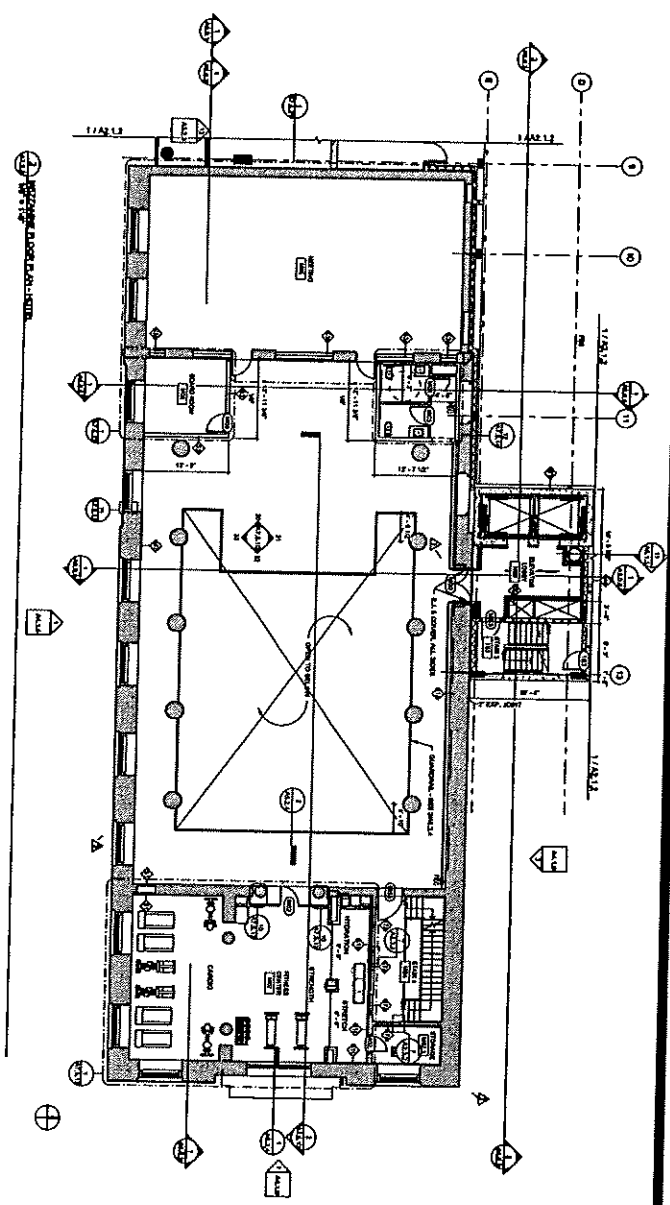
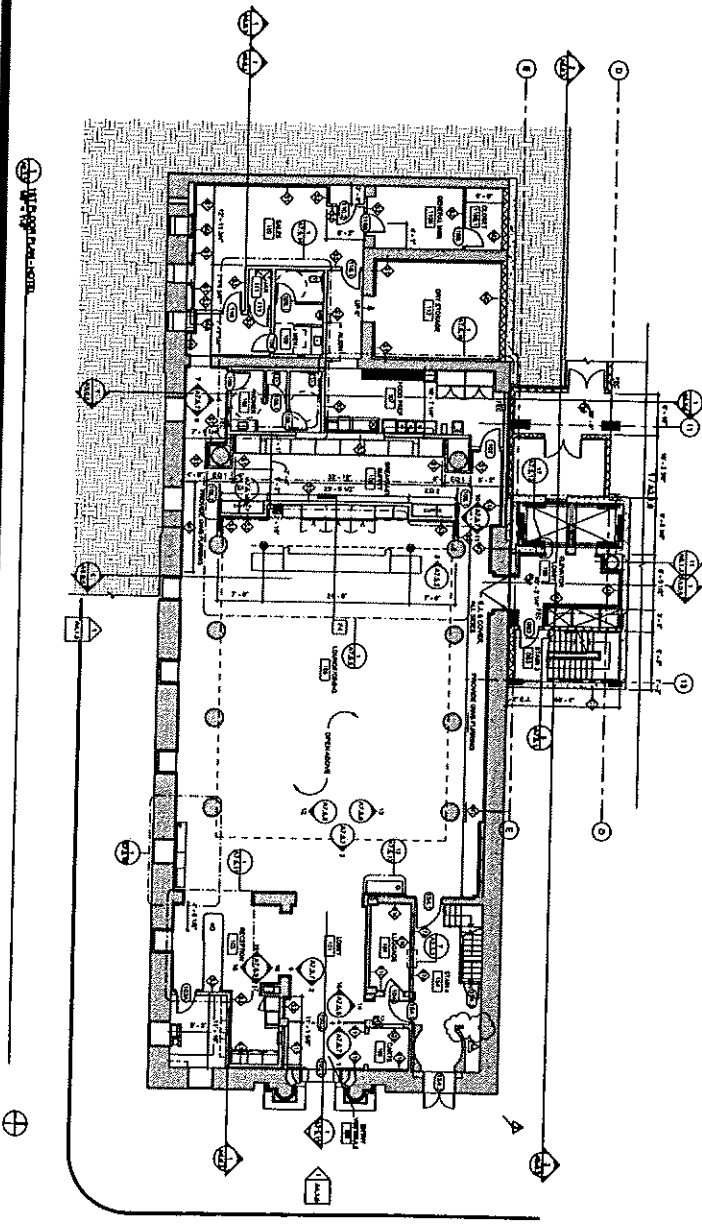

FLOOR PLAN GENERAL NOTES

1. SEE ALL NOTES ON ALL SHEETS OF THIS SET.
2. ALL WORK SHALL BE IN ACCORDANCE WITH THE LATEST EDITIONS OF THE BUILDING CODES AND REGULATIONS OF THE CITY OF BALTIMORE, MARYLAND.
3. ALL WORK SHALL BE IN ACCORDANCE WITH THE LATEST EDITIONS OF THE NATIONAL BUILDING CODES AND REGULATIONS.
4. ALL WORK SHALL BE IN ACCORDANCE WITH THE LATEST EDITIONS OF THE INTERNATIONAL CODES AND REGULATIONS.
5. ALL WORK SHALL BE IN ACCORDANCE WITH THE LATEST EDITIONS OF THE AMERICAN INSTITUTE OF ARCHITECTS (AIA) STANDARDS AND SPECIFICATIONS.
6. ALL WORK SHALL BE IN ACCORDANCE WITH THE LATEST EDITIONS OF THE AMERICAN SOCIETY OF MECHANICAL ENGINEERS (ASME) STANDARDS AND SPECIFICATIONS.
7. ALL WORK SHALL BE IN ACCORDANCE WITH THE LATEST EDITIONS OF THE AMERICAN SOCIETY OF ELECTRICAL ENGINEERS (ASEE) STANDARDS AND SPECIFICATIONS.
8. ALL WORK SHALL BE IN ACCORDANCE WITH THE LATEST EDITIONS OF THE AMERICAN SOCIETY OF CIVIL ENGINEERS (ASCE) STANDARDS AND SPECIFICATIONS.
9. ALL WORK SHALL BE IN ACCORDANCE WITH THE LATEST EDITIONS OF THE AMERICAN SOCIETY OF MECHANICAL ENGINEERS (ASME) STANDARDS AND SPECIFICATIONS.
10. ALL WORK SHALL BE IN ACCORDANCE WITH THE LATEST EDITIONS OF THE AMERICAN SOCIETY OF ELECTRICAL ENGINEERS (ASEE) STANDARDS AND SPECIFICATIONS.
11. ALL WORK SHALL BE IN ACCORDANCE WITH THE LATEST EDITIONS OF THE AMERICAN SOCIETY OF CIVIL ENGINEERS (ASCE) STANDARDS AND SPECIFICATIONS.
12. ALL WORK SHALL BE IN ACCORDANCE WITH THE LATEST EDITIONS OF THE AMERICAN SOCIETY OF MECHANICAL ENGINEERS (ASME) STANDARDS AND SPECIFICATIONS.

APARTMENTS 444

400 West Fayette Street
Baltimore, MD 21201

MOSELEYARCHITECTS

1714 WEST HANOVER AVENUE, BALTIMORE, MD 21220
PHONE (410) 528-4242 FAX (410) 528-4242
MOSELEYARCHITECTS.COM

CONSTRUCTION DOCUMENTS

A2.2.2

MEZANINE & 1ST FLOOR PLAN - HOTEL

NO.	DATE	DESCRIPTION
1	02/12/2016	ISSUED FOR PERMIT
2	02/12/2016	ISSUED FOR CONSTRUCTION
3	02/12/2016	ISSUED FOR CONSTRUCTION
4	02/12/2016	ISSUED FOR CONSTRUCTION
5	02/12/2016	ISSUED FOR CONSTRUCTION
6	02/12/2016	ISSUED FOR CONSTRUCTION
7	02/12/2016	ISSUED FOR CONSTRUCTION
8	02/12/2016	ISSUED FOR CONSTRUCTION
9	02/12/2016	ISSUED FOR CONSTRUCTION
10	02/12/2016	ISSUED FOR CONSTRUCTION
11	02/12/2016	ISSUED FOR CONSTRUCTION
12	02/12/2016	ISSUED FOR CONSTRUCTION
13	02/12/2016	ISSUED FOR CONSTRUCTION
14	02/12/2016	ISSUED FOR CONSTRUCTION
15	02/12/2016	ISSUED FOR CONSTRUCTION
16	02/12/2016	ISSUED FOR CONSTRUCTION
17	02/12/2016	ISSUED FOR CONSTRUCTION
18	02/12/2016	ISSUED FOR CONSTRUCTION
19	02/12/2016	ISSUED FOR CONSTRUCTION
20	02/12/2016	ISSUED FOR CONSTRUCTION

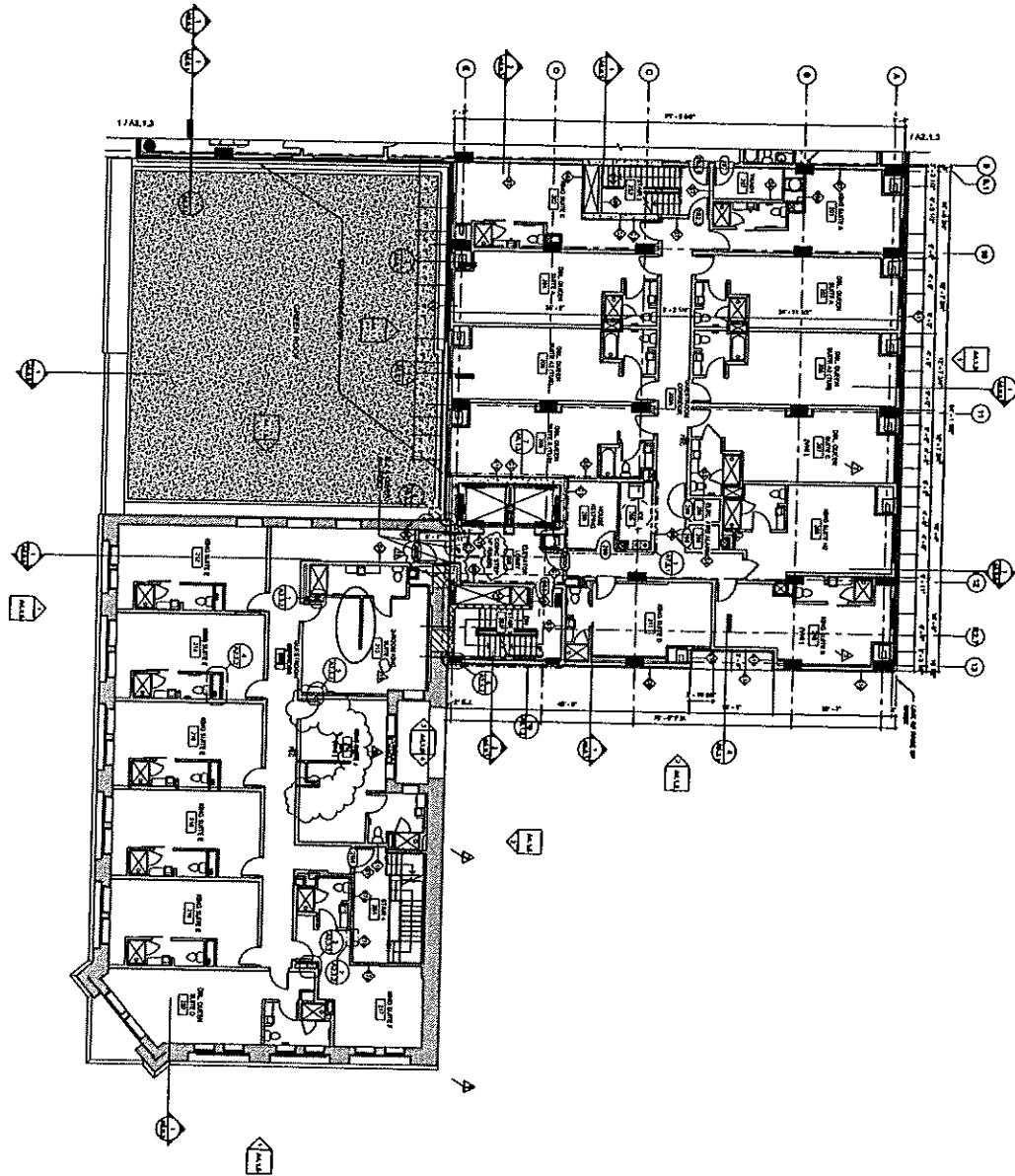

FLOOR PLAN GENERAL NOTES

1. REFER TO ALL NOTES ON ALL SHEETS OF THIS SET.
2. ALL WORK SHALL BE IN ACCORDANCE WITH THE LATEST EDITIONS OF THE BUILDING CODES AND REGULATIONS OF THE CITY OF BALTIMORE, MARYLAND.
3. ALL WORK SHALL BE IN ACCORDANCE WITH THE LATEST EDITIONS OF THE NATIONAL BUILDING CODES AND REGULATIONS OF THE INTERNATIONAL ASSOCIATION OF BUILDING OFFICIALS (IABO).
4. ALL WORK SHALL BE IN ACCORDANCE WITH THE LATEST EDITIONS OF THE NATIONAL ELECTRICAL CODE (NEC) AND THE NATIONAL FIRE ALARM AND SIGNALING CODE (NFAS).
5. ALL WORK SHALL BE IN ACCORDANCE WITH THE LATEST EDITIONS OF THE NATIONAL MECHANICAL CODE (NMC) AND THE NATIONAL PLUMBING AND HEATING CODE (NPHC).
6. ALL WORK SHALL BE IN ACCORDANCE WITH THE LATEST EDITIONS OF THE NATIONAL CONSTRUCTION CODE (NCC) AND THE NATIONAL CONSTRUCTION CODE (NCC).
7. ALL WORK SHALL BE IN ACCORDANCE WITH THE LATEST EDITIONS OF THE NATIONAL CONSTRUCTION CODE (NCC) AND THE NATIONAL CONSTRUCTION CODE (NCC).
8. ALL WORK SHALL BE IN ACCORDANCE WITH THE LATEST EDITIONS OF THE NATIONAL CONSTRUCTION CODE (NCC) AND THE NATIONAL CONSTRUCTION CODE (NCC).
9. ALL WORK SHALL BE IN ACCORDANCE WITH THE LATEST EDITIONS OF THE NATIONAL CONSTRUCTION CODE (NCC) AND THE NATIONAL CONSTRUCTION CODE (NCC).
10. ALL WORK SHALL BE IN ACCORDANCE WITH THE LATEST EDITIONS OF THE NATIONAL CONSTRUCTION CODE (NCC) AND THE NATIONAL CONSTRUCTION CODE (NCC).

APARTMENTS 444

400 West Fayette Street
Baltimore, MD 21201

MOSELEYARCHITECTS

1434 WEST HENRIEWAY, BALTIMORE, MD 21228
PHONE: 410-528-4400 FAX: 410-528-4400
WWW.MOSELEYARCHITECTS.COM

CONSTRUCTION DOCUMENTS

A2.2.3

NO.	DATE	DESCRIPTION
1	04/20/08	ISSUED FOR PERMIT
2	04/20/08	ISSUED FOR PERMIT
3	04/20/08	ISSUED FOR PERMIT
4	04/20/08	ISSUED FOR PERMIT
5	04/20/08	ISSUED FOR PERMIT
6	04/20/08	ISSUED FOR PERMIT
7	04/20/08	ISSUED FOR PERMIT
8	04/20/08	ISSUED FOR PERMIT
9	04/20/08	ISSUED FOR PERMIT
10	04/20/08	ISSUED FOR PERMIT

2ND FLOOR PLAN - HOTEL

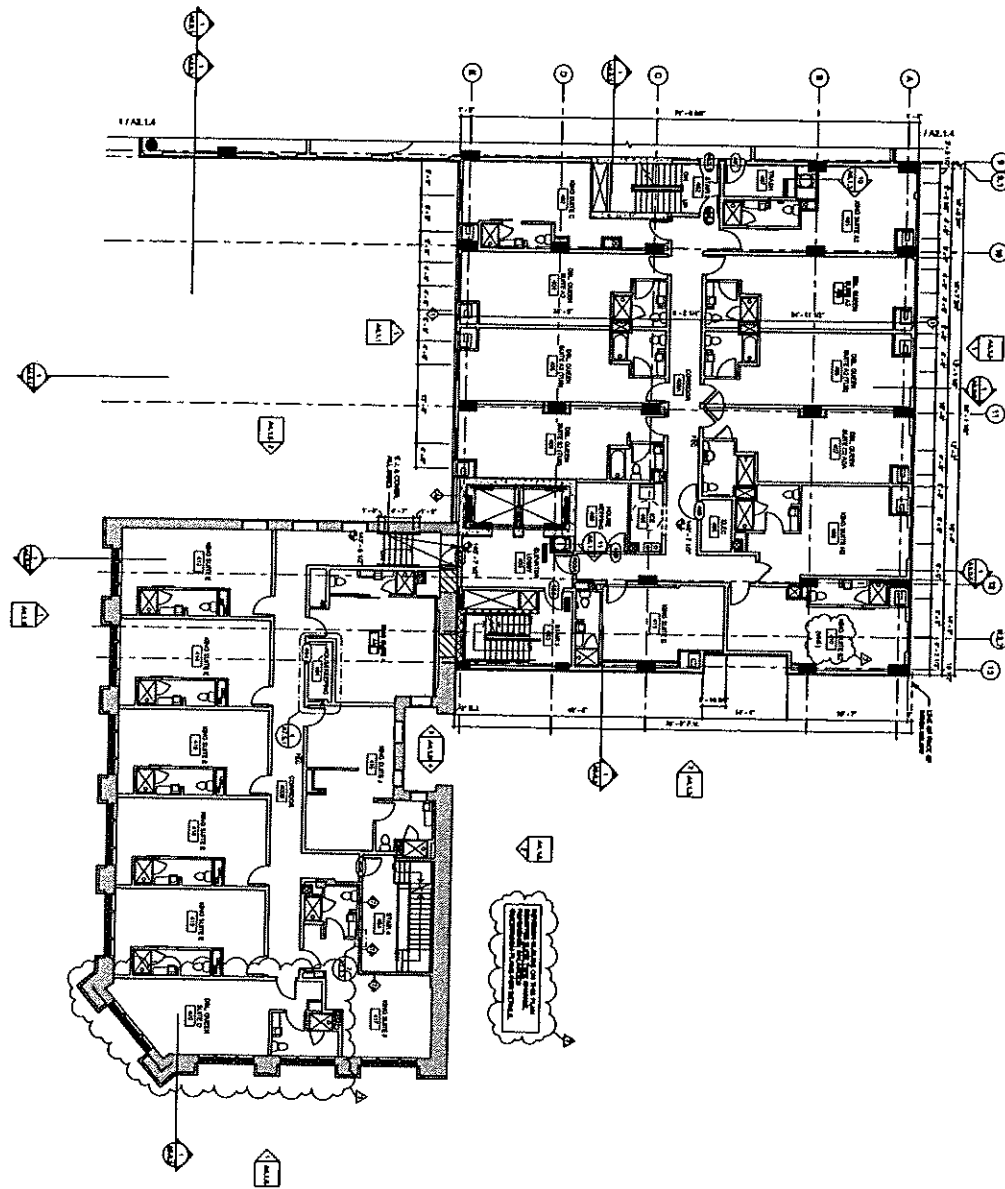

FLOOR PLAN GENERAL NOTES

1. ALL WORK SHALL BE IN ACCORDANCE WITH THE LATEST EDITIONS OF THE BUILDING CODES AND REGULATIONS OF THE CITY OF BALTIMORE.
2. THE CONTRACTOR SHALL BE RESPONSIBLE FOR OBTAINING ALL NECESSARY PERMITS AND APPROVALS FROM THE CITY OF BALTIMORE.
3. ALL MATERIALS AND WORKMANSHIP SHALL BE SUBJECT TO INSPECTION AND APPROVAL BY THE CITY OF BALTIMORE.
4. THE CONTRACTOR SHALL MAINTAIN ACCESS TO ALL ADJACENT PROPERTIES AT ALL TIMES.
5. ALL UTILITIES SHALL BE PROTECTED AND NOT TO BE MOVED OR ALTERED UNLESS SPECIFICALLY NOTED OTHERWISE.
6. THE CONTRACTOR SHALL BE RESPONSIBLE FOR THE PROTECTION OF ALL EXISTING UTILITIES AND STRUCTURES.
7. ALL WORK SHALL BE COMPLETED WITHIN THE SPECIFIED TIME FRAME.
8. THE CONTRACTOR SHALL MAINTAIN A NEAT AND ORDERLY WORK SITE AT ALL TIMES.
9. ALL MATERIALS SHALL BE STORED PROPERLY AND PROTECTED FROM THE ELEMENTS.
10. THE CONTRACTOR SHALL BE RESPONSIBLE FOR THE DISPOSAL OF ALL DEBRIS AND WASTE MATERIALS.
11. ALL WORK SHALL BE COMPLETED IN ACCORDANCE WITH THE SPECIFICATIONS AND NOTES ON THESE DRAWINGS.
12. THE CONTRACTOR SHALL BE RESPONSIBLE FOR THE PROTECTION OF ALL ADJACENT PROPERTIES AND UTILITIES.
13. ALL WORK SHALL BE COMPLETED WITHIN THE SPECIFIED TIME FRAME.
14. THE CONTRACTOR SHALL MAINTAIN A NEAT AND ORDERLY WORK SITE AT ALL TIMES.
15. ALL MATERIALS SHALL BE STORED PROPERLY AND PROTECTED FROM THE ELEMENTS.
16. THE CONTRACTOR SHALL BE RESPONSIBLE FOR THE DISPOSAL OF ALL DEBRIS AND WASTE MATERIALS.
17. ALL WORK SHALL BE COMPLETED IN ACCORDANCE WITH THE SPECIFICATIONS AND NOTES ON THESE DRAWINGS.
18. THE CONTRACTOR SHALL BE RESPONSIBLE FOR THE PROTECTION OF ALL ADJACENT PROPERTIES AND UTILITIES.
19. ALL WORK SHALL BE COMPLETED WITHIN THE SPECIFIED TIME FRAME.
20. THE CONTRACTOR SHALL MAINTAIN A NEAT AND ORDERLY WORK SITE AT ALL TIMES.
21. ALL MATERIALS SHALL BE STORED PROPERLY AND PROTECTED FROM THE ELEMENTS.
22. THE CONTRACTOR SHALL BE RESPONSIBLE FOR THE DISPOSAL OF ALL DEBRIS AND WASTE MATERIALS.
23. ALL WORK SHALL BE COMPLETED IN ACCORDANCE WITH THE SPECIFICATIONS AND NOTES ON THESE DRAWINGS.
24. THE CONTRACTOR SHALL BE RESPONSIBLE FOR THE PROTECTION OF ALL ADJACENT PROPERTIES AND UTILITIES.
25. ALL WORK SHALL BE COMPLETED WITHIN THE SPECIFIED TIME FRAME.
26. THE CONTRACTOR SHALL MAINTAIN A NEAT AND ORDERLY WORK SITE AT ALL TIMES.
27. ALL MATERIALS SHALL BE STORED PROPERLY AND PROTECTED FROM THE ELEMENTS.
28. THE CONTRACTOR SHALL BE RESPONSIBLE FOR THE DISPOSAL OF ALL DEBRIS AND WASTE MATERIALS.
29. ALL WORK SHALL BE COMPLETED IN ACCORDANCE WITH THE SPECIFICATIONS AND NOTES ON THESE DRAWINGS.
30. THE CONTRACTOR SHALL BE RESPONSIBLE FOR THE PROTECTION OF ALL ADJACENT PROPERTIES AND UTILITIES.

APARTMENTS 444

444 West Fayette Street
Baltimore, MD 21201

MOSELEYARCHITECTS

6114 REY HERMAN, BALTIMORE, MD 21220
PHONE (410) 524-0268 FAX (410) 524-0268
MOSELEYARCHITECTS.COM

CONSTRUCTION
DOCUMENTS

A2.2.5

3TH FLOOR PLAN -
HOTEL

NO.	DATE	DESCRIPTION
1	04/28/18	ISSUED FOR PERMITTING
2	04/28/18	ISSUED FOR CONSTRUCTION
3	04/28/18	ISSUED FOR RECORD

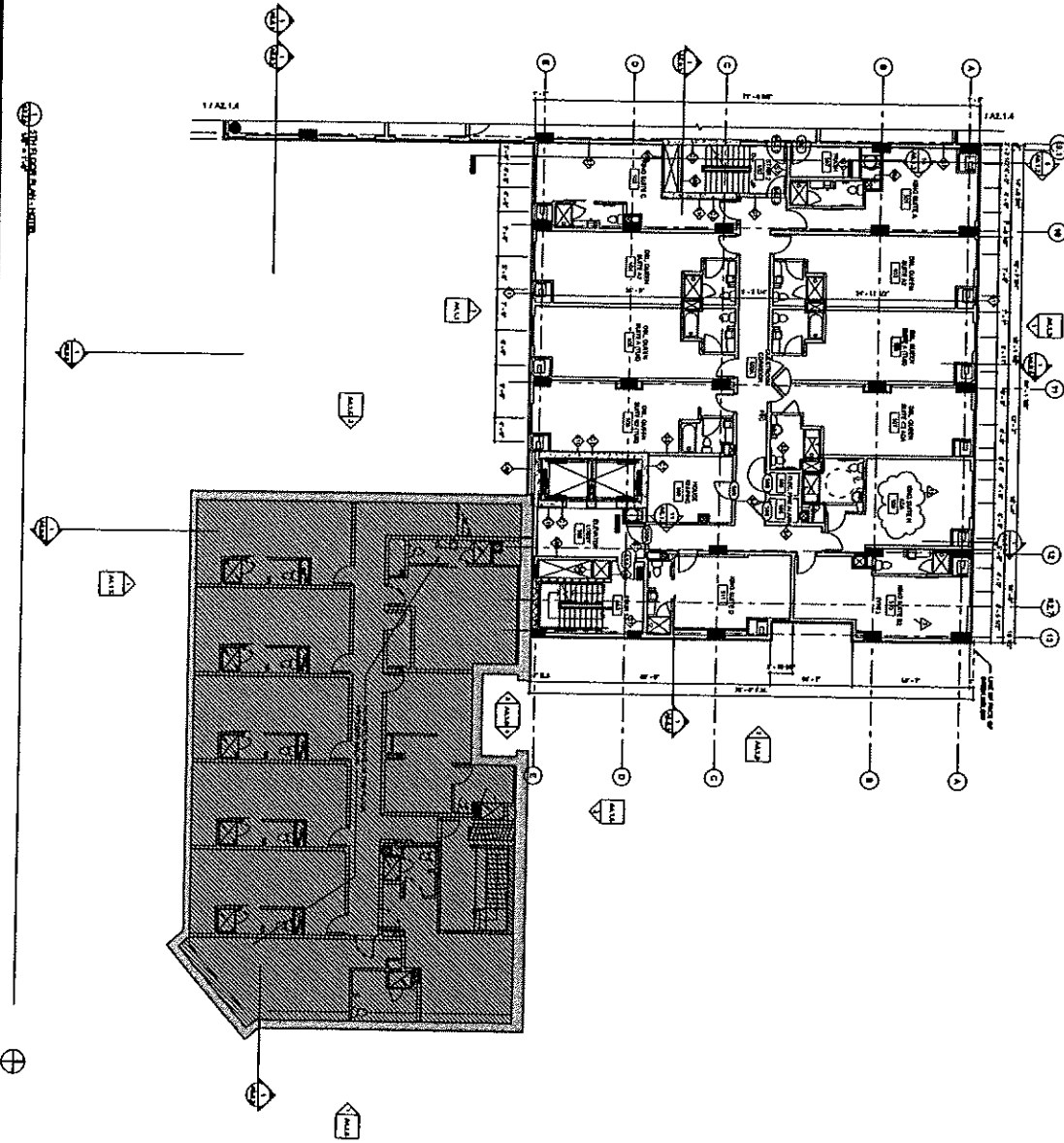

FLOOR PLAN GENERAL NOTES

1. ALL WORK SHALL BE IN ACCORDANCE WITH THE LATEST EDITIONS OF THE BUILDING CODES AND REGULATIONS.
2. THE CONTRACTOR SHALL BE RESPONSIBLE FOR OBTAINING ALL NECESSARY PERMITS AND APPROVALS FROM THE APPLICABLE AGENCIES.
3. THE CONTRACTOR SHALL MAINTAIN ACCESS TO ALL ADJACENT PROPERTIES AND UTILITIES AT ALL TIMES.
4. ALL MATERIALS AND WORKMANSHIP SHALL BE SUBJECT TO INSPECTION AND APPROVAL BY THE ARCHITECT AND THE APPLICABLE AGENCIES.
5. THE CONTRACTOR SHALL BE RESPONSIBLE FOR PROTECTING ALL EXISTING UTILITIES AND STRUCTURES TO REMAIN.
6. ALL WORK SHALL BE COMPLETED WITHIN THE SPECIFIED TIME FRAME.
7. THE CONTRACTOR SHALL MAINTAIN A NEAT AND ORDERLY WORK SITE AT ALL TIMES.
8. ALL WASTE MATERIALS SHALL BE PROPERLY DISPOSED OF AT THE END OF EACH WORK DAY.
9. THE CONTRACTOR SHALL BE RESPONSIBLE FOR OBTAINING ALL NECESSARY INSURANCE COVERAGE.
10. ALL WORK SHALL BE COMPLETED IN ACCORDANCE WITH THE SPECIFICATIONS AND NOTES.

APARTMENTS 444

408 West Fayette Street
Baltimore, MD 21201

MOSELEYARCHITECTS

1514 BETHESDA ROAD, BALTIMORE, MD 21204
PHONE 410-528-0200 FAX 410-528-0202
MOSELEYARCHITECTS.COM

CONSTRUCTION DOCUMENTS

A2.2.6

NO.	DATE	DESCRIPTION
1	10/15/14	ISSUED FOR PERMITTING
2	10/20/14	ISSUED FOR CONSTRUCTION
3	11/05/14	ISSUED FOR CONSTRUCTION
4	11/10/14	ISSUED FOR CONSTRUCTION
5	11/15/14	ISSUED FOR CONSTRUCTION
6	11/20/14	ISSUED FOR CONSTRUCTION
7	11/25/14	ISSUED FOR CONSTRUCTION
8	12/01/14	ISSUED FOR CONSTRUCTION
9	12/05/14	ISSUED FOR CONSTRUCTION
10	12/10/14	ISSUED FOR CONSTRUCTION
11	12/15/14	ISSUED FOR CONSTRUCTION
12	12/20/14	ISSUED FOR CONSTRUCTION
13	12/25/14	ISSUED FOR CONSTRUCTION
14	01/05/15	ISSUED FOR CONSTRUCTION
15	01/10/15	ISSUED FOR CONSTRUCTION
16	01/15/15	ISSUED FOR CONSTRUCTION
17	01/20/15	ISSUED FOR CONSTRUCTION
18	01/25/15	ISSUED FOR CONSTRUCTION
19	02/01/15	ISSUED FOR CONSTRUCTION
20	02/05/15	ISSUED FOR CONSTRUCTION
21	02/10/15	ISSUED FOR CONSTRUCTION
22	02/15/15	ISSUED FOR CONSTRUCTION
23	02/20/15	ISSUED FOR CONSTRUCTION
24	02/25/15	ISSUED FOR CONSTRUCTION
25	03/01/15	ISSUED FOR CONSTRUCTION
26	03/05/15	ISSUED FOR CONSTRUCTION
27	03/10/15	ISSUED FOR CONSTRUCTION
28	03/15/15	ISSUED FOR CONSTRUCTION
29	03/20/15	ISSUED FOR CONSTRUCTION
30	03/25/15	ISSUED FOR CONSTRUCTION
31	04/01/15	ISSUED FOR CONSTRUCTION
32	04/05/15	ISSUED FOR CONSTRUCTION
33	04/10/15	ISSUED FOR CONSTRUCTION
34	04/15/15	ISSUED FOR CONSTRUCTION
35	04/20/15	ISSUED FOR CONSTRUCTION
36	04/25/15	ISSUED FOR CONSTRUCTION
37	05/01/15	ISSUED FOR CONSTRUCTION
38	05/05/15	ISSUED FOR CONSTRUCTION
39	05/10/15	ISSUED FOR CONSTRUCTION
40	05/15/15	ISSUED FOR CONSTRUCTION
41	05/20/15	ISSUED FOR CONSTRUCTION
42	05/25/15	ISSUED FOR CONSTRUCTION
43	06/01/15	ISSUED FOR CONSTRUCTION
44	06/05/15	ISSUED FOR CONSTRUCTION
45	06/10/15	ISSUED FOR CONSTRUCTION
46	06/15/15	ISSUED FOR CONSTRUCTION
47	06/20/15	ISSUED FOR CONSTRUCTION
48	06/25/15	ISSUED FOR CONSTRUCTION
49	07/01/15	ISSUED FOR CONSTRUCTION
50	07/05/15	ISSUED FOR CONSTRUCTION
51	07/10/15	ISSUED FOR CONSTRUCTION
52	07/15/15	ISSUED FOR CONSTRUCTION
53	07/20/15	ISSUED FOR CONSTRUCTION
54	07/25/15	ISSUED FOR CONSTRUCTION
55	08/01/15	ISSUED FOR CONSTRUCTION
56	08/05/15	ISSUED FOR CONSTRUCTION
57	08/10/15	ISSUED FOR CONSTRUCTION
58	08/15/15	ISSUED FOR CONSTRUCTION
59	08/20/15	ISSUED FOR CONSTRUCTION
60	08/25/15	ISSUED FOR CONSTRUCTION
61	09/01/15	ISSUED FOR CONSTRUCTION
62	09/05/15	ISSUED FOR CONSTRUCTION
63	09/10/15	ISSUED FOR CONSTRUCTION
64	09/15/15	ISSUED FOR CONSTRUCTION
65	09/20/15	ISSUED FOR CONSTRUCTION
66	09/25/15	ISSUED FOR CONSTRUCTION
67	10/01/15	ISSUED FOR CONSTRUCTION
68	10/05/15	ISSUED FOR CONSTRUCTION
69	10/10/15	ISSUED FOR CONSTRUCTION
70	10/15/15	ISSUED FOR CONSTRUCTION
71	10/20/15	ISSUED FOR CONSTRUCTION
72	10/25/15	ISSUED FOR CONSTRUCTION
73	11/01/15	ISSUED FOR CONSTRUCTION
74	11/05/15	ISSUED FOR CONSTRUCTION
75	11/10/15	ISSUED FOR CONSTRUCTION
76	11/15/15	ISSUED FOR CONSTRUCTION
77	11/20/15	ISSUED FOR CONSTRUCTION
78	11/25/15	ISSUED FOR CONSTRUCTION
79	12/01/15	ISSUED FOR CONSTRUCTION
80	12/05/15	ISSUED FOR CONSTRUCTION
81	12/10/15	ISSUED FOR CONSTRUCTION
82	12/15/15	ISSUED FOR CONSTRUCTION
83	12/20/15	ISSUED FOR CONSTRUCTION
84	12/25/15	ISSUED FOR CONSTRUCTION
85	01/01/16	ISSUED FOR CONSTRUCTION
86	01/05/16	ISSUED FOR CONSTRUCTION
87	01/10/16	ISSUED FOR CONSTRUCTION
88	01/15/16	ISSUED FOR CONSTRUCTION
89	01/20/16	ISSUED FOR CONSTRUCTION
90	01/25/16	ISSUED FOR CONSTRUCTION
91	02/01/16	ISSUED FOR CONSTRUCTION
92	02/05/16	ISSUED FOR CONSTRUCTION
93	02/10/16	ISSUED FOR CONSTRUCTION
94	02/15/16	ISSUED FOR CONSTRUCTION
95	02/20/16	ISSUED FOR CONSTRUCTION
96	02/25/16	ISSUED FOR CONSTRUCTION
97	03/01/16	ISSUED FOR CONSTRUCTION
98	03/05/16	ISSUED FOR CONSTRUCTION
99	03/10/16	ISSUED FOR CONSTRUCTION
100	03/15/16	ISSUED FOR CONSTRUCTION

5TH FLOOR PLAN - HOTEL

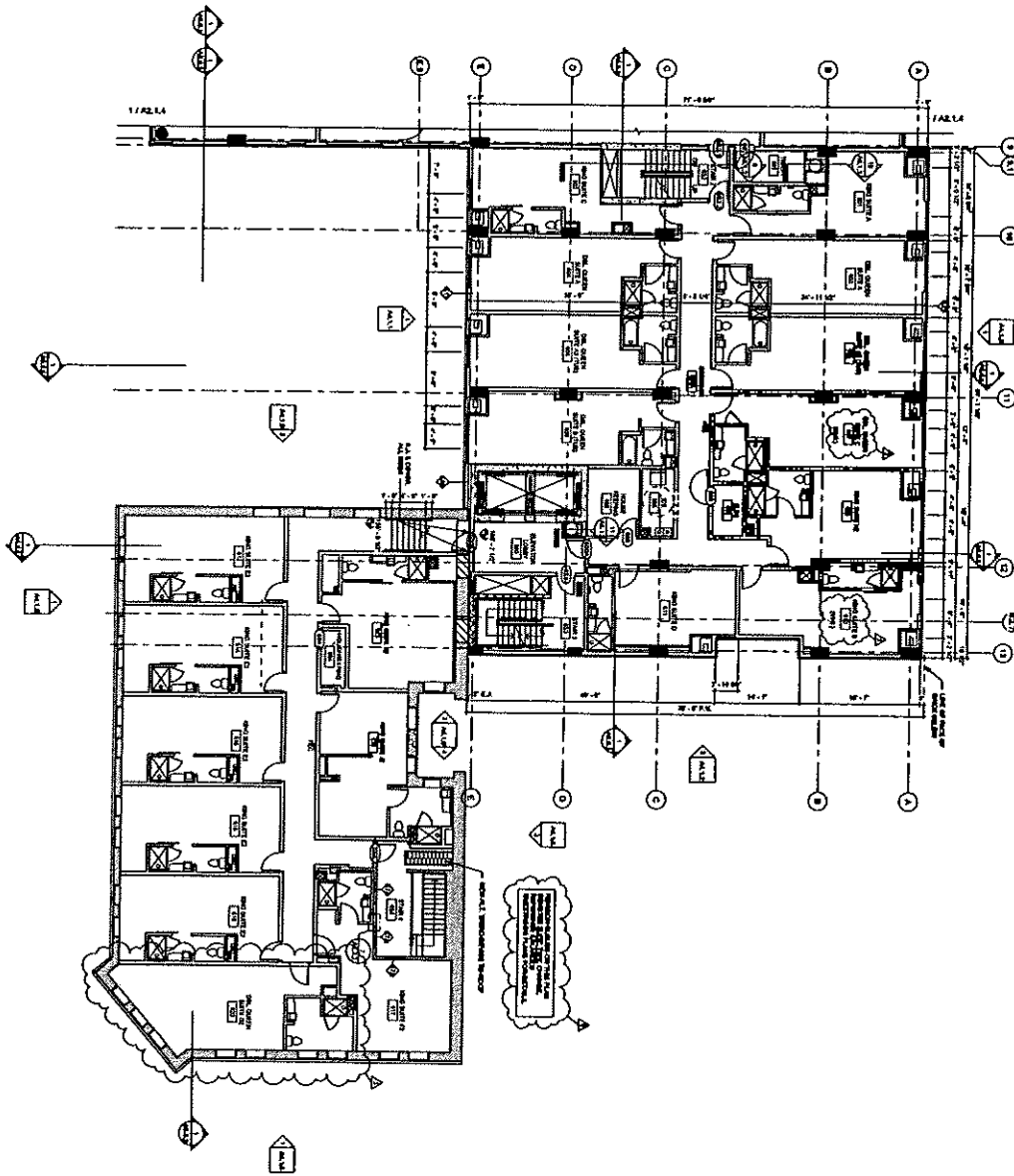

FLOOR PLAN GENERAL NOTES

1. ALL WORK SHALL BE IN ACCORDANCE WITH THE LATEST EDITIONS OF THE BUILDING CODES AND REGULATIONS OF THE CITY OF BALTIMORE.
2. ALL WORK SHALL BE IN ACCORDANCE WITH THE LATEST EDITIONS OF THE NATIONAL BUILDING CODES AND REGULATIONS.
3. ALL WORK SHALL BE IN ACCORDANCE WITH THE LATEST EDITIONS OF THE INTERNATIONAL CODES AND REGULATIONS.
4. ALL WORK SHALL BE IN ACCORDANCE WITH THE LATEST EDITIONS OF THE NATIONAL FIRE PROTECTION ASSOCIATION (NFPA) CODES AND REGULATIONS.
5. ALL WORK SHALL BE IN ACCORDANCE WITH THE LATEST EDITIONS OF THE NATIONAL ELECTRICAL CODE (NEC) AND REGULATIONS.
6. ALL WORK SHALL BE IN ACCORDANCE WITH THE LATEST EDITIONS OF THE NATIONAL MECHANICAL CODE (NMC) AND REGULATIONS.
7. ALL WORK SHALL BE IN ACCORDANCE WITH THE LATEST EDITIONS OF THE NATIONAL PLUMBING CODE (NPC) AND REGULATIONS.
8. ALL WORK SHALL BE IN ACCORDANCE WITH THE LATEST EDITIONS OF THE NATIONAL GAS CODE (NGC) AND REGULATIONS.
9. ALL WORK SHALL BE IN ACCORDANCE WITH THE LATEST EDITIONS OF THE NATIONAL PEST CONTROL CODE (NPC) AND REGULATIONS.
10. ALL WORK SHALL BE IN ACCORDANCE WITH THE LATEST EDITIONS OF THE NATIONAL INSULATION CODE (NIC) AND REGULATIONS.
11. ALL WORK SHALL BE IN ACCORDANCE WITH THE LATEST EDITIONS OF THE NATIONAL ROOFING CODE (NRC) AND REGULATIONS.
12. ALL WORK SHALL BE IN ACCORDANCE WITH THE LATEST EDITIONS OF THE NATIONAL SPOKESMAN CODE (NSC) AND REGULATIONS.
13. ALL WORK SHALL BE IN ACCORDANCE WITH THE LATEST EDITIONS OF THE NATIONAL WOODWORKING CODE (NWC) AND REGULATIONS.
14. ALL WORK SHALL BE IN ACCORDANCE WITH THE LATEST EDITIONS OF THE NATIONAL PAINTING CODE (NPC) AND REGULATIONS.

APARTMENTS 444

444 West Fayette Street
Baltimore, MD 21201

MOSELEYARCHITECTS

1414 RIVINGTON, BALTIMORE, MD 21202
PHONE: 410-754-0040 FAX: 410-754-0040
MOSELEYARCHITECTS.COM

CONSTRUCTION DOCUMENTS

NO.	DATE	DESCRIPTION
1	12/20/19	ISSUED FOR PERMIT
2	12/20/19	ISSUED FOR CONSTRUCTION
3	12/20/19	ISSUED FOR OCCUPANCY

A2.27

3RD FLOOR PLAN - HOTEL

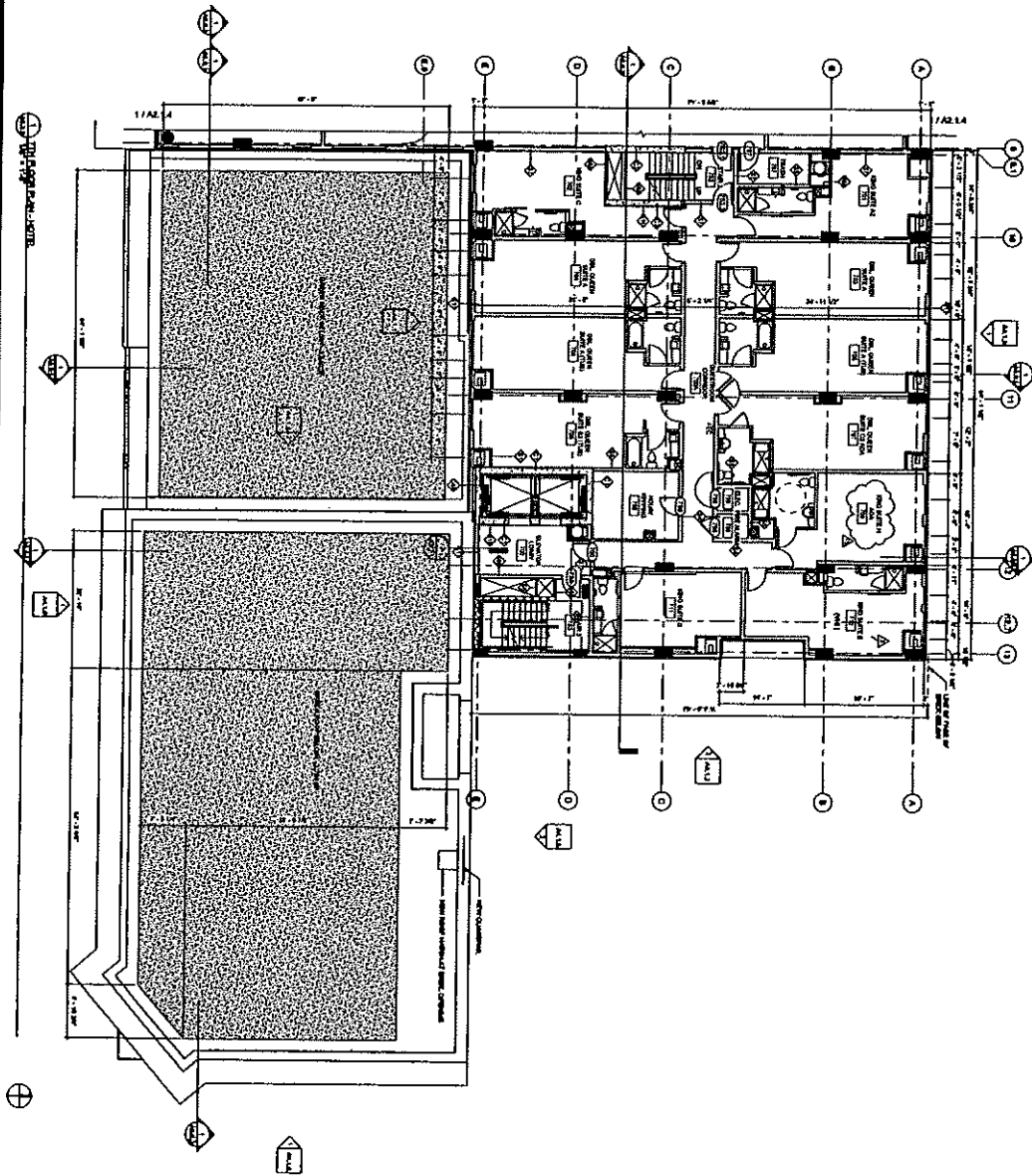

FLOOR PLAN GENERAL NOTES

1. ALL WORK SHALL BE IN ACCORDANCE WITH THE 2012 INTERNATIONAL RESIDENTIAL CODE BOOK (IRC) AND THE 2012 INTERNATIONAL MECHANICAL AND ELECTRICAL CODE (IMC).
2. ALL WORK SHALL BE IN ACCORDANCE WITH THE 2012 INTERNATIONAL BUILDING CODE (IBC).
3. ALL WORK SHALL BE IN ACCORDANCE WITH THE 2012 INTERNATIONAL PLUMBING AND MECHANICAL CODE (IPMC).
4. ALL WORK SHALL BE IN ACCORDANCE WITH THE 2012 INTERNATIONAL ELECTRICAL CODE (IEC).
5. ALL WORK SHALL BE IN ACCORDANCE WITH THE 2012 INTERNATIONAL FIRE AND ALARM CODE (IFAC).
6. ALL WORK SHALL BE IN ACCORDANCE WITH THE 2012 INTERNATIONAL SMOKE ALARM CODE (ISAC).
7. ALL WORK SHALL BE IN ACCORDANCE WITH THE 2012 INTERNATIONAL ENERGY CONSERVATION CODE (IECC).
8. ALL WORK SHALL BE IN ACCORDANCE WITH THE 2012 INTERNATIONAL GREEN BUILDING CODE (IGBC).
9. ALL WORK SHALL BE IN ACCORDANCE WITH THE 2012 INTERNATIONAL WELLNESS BUILDING INSTITUTE (IWBI) WELL-BEINGING CERTIFICATION PROGRAM (WELL).
10. ALL WORK SHALL BE IN ACCORDANCE WITH THE 2012 INTERNATIONAL WELLNESS BUILDING INSTITUTE (IWBI) WELL-BEINGING CERTIFICATION PROGRAM (WELL).
11. ALL WORK SHALL BE IN ACCORDANCE WITH THE 2012 INTERNATIONAL WELLNESS BUILDING INSTITUTE (IWBI) WELL-BEINGING CERTIFICATION PROGRAM (WELL).
12. ALL WORK SHALL BE IN ACCORDANCE WITH THE 2012 INTERNATIONAL WELLNESS BUILDING INSTITUTE (IWBI) WELL-BEINGING CERTIFICATION PROGRAM (WELL).

PROJECT NO.	444
DATE	02/25/2014
SCALE	AS SHOWN
DRAWN BY	[Name]
CHECKED BY	[Name]
APPROVED BY	[Name]

APARTMENTS 444

400 West Fayette Street
Baltimore, MD 21201

CONSTRUCTION DOCUMENTS

MOSELEYARCHITECTS

1404 WEST FAYETTE STREET, BALTIMORE, MD 21201
PHONE: 410.528.1200 FAX: 410.528.1201
WWW.MOSELEYARCHITECTS.COM

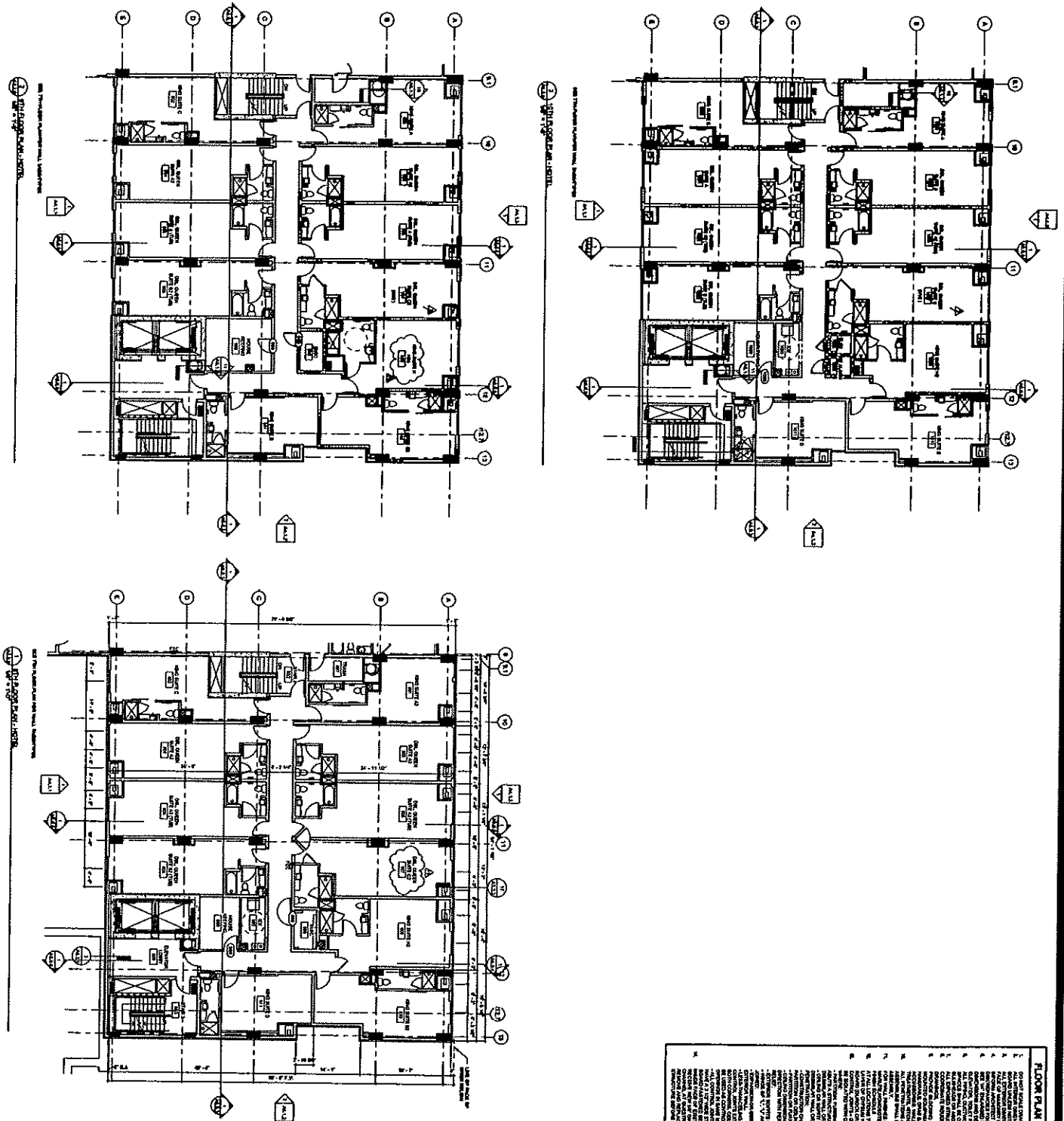

FLOOR PLAN GENERAL NOTES

1. THE CONTRACTOR SHALL BE RESPONSIBLE FOR OBTAINING ALL NECESSARY PERMITS AND APPROVALS FROM THE APPLICABLE AGENCIES AND AUTHORITIES.
2. THE CONTRACTOR SHALL BE RESPONSIBLE FOR OBTAINING ALL NECESSARY PERMITS AND APPROVALS FROM THE APPLICABLE AGENCIES AND AUTHORITIES.
3. THE CONTRACTOR SHALL BE RESPONSIBLE FOR OBTAINING ALL NECESSARY PERMITS AND APPROVALS FROM THE APPLICABLE AGENCIES AND AUTHORITIES.
4. THE CONTRACTOR SHALL BE RESPONSIBLE FOR OBTAINING ALL NECESSARY PERMITS AND APPROVALS FROM THE APPLICABLE AGENCIES AND AUTHORITIES.
5. THE CONTRACTOR SHALL BE RESPONSIBLE FOR OBTAINING ALL NECESSARY PERMITS AND APPROVALS FROM THE APPLICABLE AGENCIES AND AUTHORITIES.
6. THE CONTRACTOR SHALL BE RESPONSIBLE FOR OBTAINING ALL NECESSARY PERMITS AND APPROVALS FROM THE APPLICABLE AGENCIES AND AUTHORITIES.
7. THE CONTRACTOR SHALL BE RESPONSIBLE FOR OBTAINING ALL NECESSARY PERMITS AND APPROVALS FROM THE APPLICABLE AGENCIES AND AUTHORITIES.
8. THE CONTRACTOR SHALL BE RESPONSIBLE FOR OBTAINING ALL NECESSARY PERMITS AND APPROVALS FROM THE APPLICABLE AGENCIES AND AUTHORITIES.
9. THE CONTRACTOR SHALL BE RESPONSIBLE FOR OBTAINING ALL NECESSARY PERMITS AND APPROVALS FROM THE APPLICABLE AGENCIES AND AUTHORITIES.
10. THE CONTRACTOR SHALL BE RESPONSIBLE FOR OBTAINING ALL NECESSARY PERMITS AND APPROVALS FROM THE APPLICABLE AGENCIES AND AUTHORITIES.

APARTMENTS 444

400 West Fayette Street
Baltimore, MD 21201

MOSELEYARCHITECTS

1414 KEY HIGHWAY, BALTIMORE, MD 21202
PHONE: 410-552-1000 FAX: 410-552-8000
MOSELEYARCHITECTS.COM

CONSTRUCTION DOCUMENTS

A2.2.9

1ST - 10th FLOOR PLANS - HOTEL

NO.	DATE	DESCRIPTION
1	2-14-16	ISSUED FOR PERMITS
2	2-14-16	ISSUED FOR PERMITS
3	2-14-16	ISSUED FOR PERMITS
4	2-14-16	ISSUED FOR PERMITS
5	2-14-16	ISSUED FOR PERMITS
6	2-14-16	ISSUED FOR PERMITS
7	2-14-16	ISSUED FOR PERMITS
8	2-14-16	ISSUED FOR PERMITS
9	2-14-16	ISSUED FOR PERMITS
10	2-14-16	ISSUED FOR PERMITS

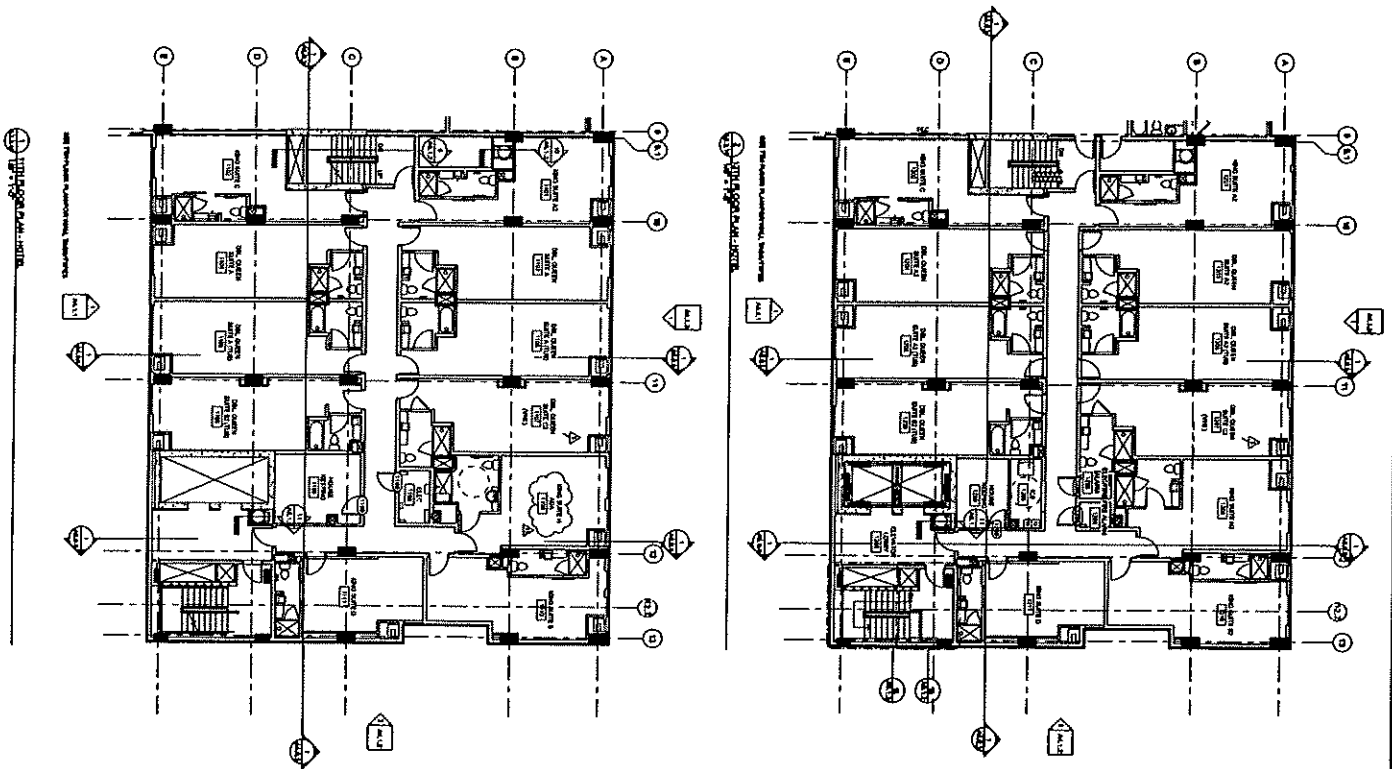

FLOOR PLAN GENERAL NOTES

1. ALL WORK SHALL BE IN ACCORDANCE WITH THE LATEST EDITIONS OF THE BUILDING CODES AND REGULATIONS.
2. ALL WORK SHALL BE IN ACCORDANCE WITH THE LATEST EDITIONS OF THE NATIONAL BUILDING CODES AND REGULATIONS.
3. ALL WORK SHALL BE IN ACCORDANCE WITH THE LATEST EDITIONS OF THE INTERNATIONAL CODES AND REGULATIONS.
4. ALL WORK SHALL BE IN ACCORDANCE WITH THE LATEST EDITIONS OF THE AMERICAN NATIONAL STANDARDS INSTITUTE (ANSI) STANDARDS.
5. ALL WORK SHALL BE IN ACCORDANCE WITH THE LATEST EDITIONS OF THE AMERICAN SOCIETY OF MECHANICAL ENGINEERS (ASME) STANDARDS.
6. ALL WORK SHALL BE IN ACCORDANCE WITH THE LATEST EDITIONS OF THE AMERICAN SOCIETY OF ELECTRICAL ENGINEERS (ASSE) STANDARDS.
7. ALL WORK SHALL BE IN ACCORDANCE WITH THE LATEST EDITIONS OF THE AMERICAN SOCIETY OF MECHANICAL ENGINEERS (ASME) STANDARDS.
8. ALL WORK SHALL BE IN ACCORDANCE WITH THE LATEST EDITIONS OF THE AMERICAN SOCIETY OF ELECTRICAL ENGINEERS (ASSE) STANDARDS.
9. ALL WORK SHALL BE IN ACCORDANCE WITH THE LATEST EDITIONS OF THE AMERICAN SOCIETY OF MECHANICAL ENGINEERS (ASME) STANDARDS.
10. ALL WORK SHALL BE IN ACCORDANCE WITH THE LATEST EDITIONS OF THE AMERICAN SOCIETY OF ELECTRICAL ENGINEERS (ASSE) STANDARDS.

APARTMENTS 444

400 West Fayette Street
Baltimore, MD 21201

MOSELEYARCHITECTS

1104 NEE FERRYWAY, BALTIMORE, MD 21204
PHONE: 410.528.4000 FAX: 410.528.4001
WWW.MOSELEYARCHITECTS.COM

CONSTRUCTION
DOCUMENTS

A2.2.10

NO.	DESCRIPTION	DATE
1	ISSUED FOR PERMIT	09/20/23
2	ISSUED FOR CONSTRUCTION	09/20/23
3	ISSUED FOR OCCUPANCY	09/20/23
4	ISSUED FOR AS-BUILT	09/20/23
5	ISSUED FOR FINAL REVIEW	09/20/23
6	ISSUED FOR ARCHIVE	09/20/23

MENUS

BREAKFAST

Pork Sausage on Cheddar Biscuit
Egg and Swiss on English Muffin
Ham, Egg and Cheese on Croissant Roll
Beef and Potato Burrito
Chorizo Burrito
Egg, Sausage and Cheese on Whole Wheat Bagel
Spinach & Cheese Crustless Quiche
Tomato, Kale, Feta & Egg White Frittata
Jalapeno Three-Cheese Baked Souffle
Pearl Sugar Waffle
Mason Dixie Scones
Mason Dixie Petit Cheddar Biscuit

LUNCH/DINNER

White Corn Tortilla Chips & Salsa
Hummus & Pita Chips
Popcorn with Smoked Paprika
Mediterranean Spiced Olives
Sesame Teriyaki Cashews & Almonds
Caesar Salad (with optional chicken)
Spinach Salad, Egg, Scallion & Ranch (with optional chicken)
Turkey on Whole Grain Toast or Twin Croissants
Ham, Havarti and Spinach Wrap
Quesadilla (optional add chicken)
Chicken and Apple Flatbread
Tomato and Margarita Flatbread
Crispy Sweet and Spicy Chicken Bites

SWEET TREATS

Toffee Blondie
Lemon Bar
Chocolate Chunk Brownie
Marshmallow Treat

SNACKS

Hummus

Chips

Candy

Cookies

Snack Bars

Nuts & Mixes

Ice Cream

Sodas

PHOTA-FD BALTIMORE, LLC: Z19458884

Department ID Number:

Z19458884

Business Name:

PHOTA-FD BALTIMORE, LLC

Principal Office: 

3500 LENOX ROAD

SUITE 625

ATLANTA GA 21122

Resident Agent: 

FOCUS DEVELOPMENT, LLC

509 SOUTH EXETER STREET

SUITE 505

PASADENA MD 21122

Status:

ACTIVE

Good Standing:

THIS BUSINESS IS IN GOOD STANDING

Business Type:

FOREIGN LLC

Business Code:

20 ENTITIES OTHER THAN CORPORATIONS

Date of Formation/ Registration:

02/26/2019

State of Formation:

GA

Stock Status:

N/A

Close Status:

N/A

PROPOSED LOCATION: 400 W. Fayette St.

MAP SUMMARY (RECAPITULATION)

TOTAL ESTABLISHMENTS IN MAP AREA 6

"A" BEER & WINE _____

"B" BEER & WINE _____

"C" BEER & WINE _____

"D" BEER & WINE _____

"A" BEER, WINE & LIQUOR _____

"A-2" BEER, WINE & LIQUOR _____

"B" BEER, WINE & LIQUOR 2

"C" BEER, WINE & LIQUOR _____

"D" BEER, WINE & LIQUOR _____

"BD7" BEER, WINE & LIQUOR 4

ARENA _____

HOTEL/MOTEL _____

RACING _____

PREPARED BY: Chase DATE: 9/20/22

400 W. Fayette St.

Licensed Establishments

- SpringHill Suites LB
- Hippodrome Theatre LBD7
- Forno Restaurant + Wine Bar LB
- Everyman Theatre LBD7
- Howard Discount Liquors LBD7
- Nando's PERi-PERi LB
- Mirage LBD7

Churches

- Westminster Presbyterian Church

This map displays the area around 400 W. Fayette St. in Baltimore, Maryland. Key features include:

- Landmarks & Businesses:** Lexington Market (Landmark food market established in 1782), Atrium Garage, Prosper On Fayette, Edgar Allan Poe's Grave (Tombstone of acclaimed American writer), Hippodrome Theatre, Nando's PERi-PERi (Chicken + CS), University of Maryland Medical Center, UMMC, and Bromo Seltzer Arts Tower (Landmark tower with art studios).
- Streets:** Lexington St & Light Station Sb, W Fayette St, W Baltimore St, W Redwood St, Paca St, Greene St, Cider Alley, Howard St, and Camden Court.
- Transit:** Lexington Market Light Station Sb, Baltimore Street, and Camden Court Apartment.
- Other Points of Interest:** United States Postal Service, MVA Approved Tag & Title Agent & Notary..., Edgar Allan Poe's Grave, Va Medical Center-Dental clinic..., and various parking areas.

Board of Liquor License Commissioners

For Baltimore City
1 North Charles Street, 15th Floor
Baltimore, Maryland, 21201

INSPECTORS REPORT - TRANSFERS/NEW APPLICATIONS

Licensee Information (Trade Name):	Springhill Suites
Corporation Name:	PHOTA-FD Baltimore, LLC
Location Address:	400 W. Fayette St.
License Type:	Class "B" Beer, Wine and Liquor <input type="checkbox"/>
Is the establishment open and operating in a safe and sanitary manner? (If not open, not in comments - CLOSED or NOT OPERATING)	No <input type="checkbox"/>
Is the location within 300 feet of Church and/or School?	Yes <input type="checkbox"/>
Date Posted?	9/19/2022 <input type="checkbox"/>
Estimated Date of Removal?	9/28/2022 <input type="checkbox"/>
Are there any other licensed establishments within a two block radius?	Yes <input type="checkbox"/>

Other licensed locations - Describe/Note:

Please see maps for additional locations

Comments and Follow-up Items(s) (please note any issues or concerns about the location):

Filed application for New "B" license .
The establishment is closed.

Insert Photo of Sign and location:

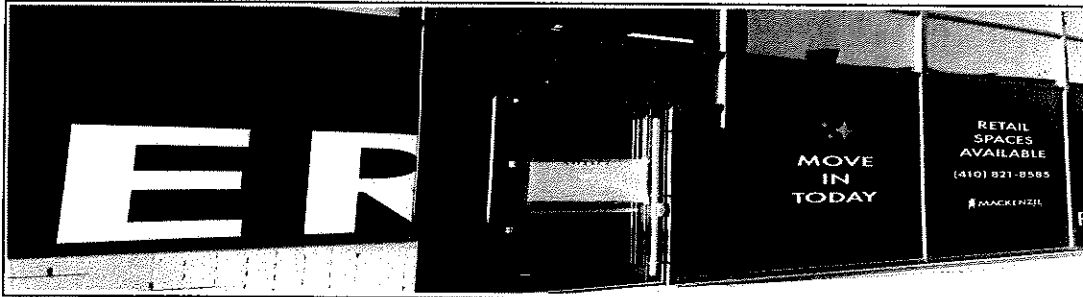

Attach Additional Photos

Inspector Name

Date and Time

j:0#.w/baltimore\terri.chase

9/20/2022

11:53:44 AM

Name of Licensee (if present)

Approve

Disapprove

Board of Liquor License Commissioners

For Baltimore City
1 North Charles Street, 15th Floor
Baltimore, Maryland, 21201

POSTING SIGNS REPORT

Applicant(s) Name: Kathryn D. Barrett; Kristopher Beck

Address of Premises: 400 W. Fayette St.

Inspector: i:\0#\w\baltimore\terri.chase

Date Posted: 9/19/2022

Time Posted: 6:00 PM

Date Rechecked:

Time Rechecked:

Manager or Owner when sign posted: N/A

Summary on location of sign posted:

The sign is posted on the front door

Summary on location of sign rechecked:

Insert Photo of Sign and location:

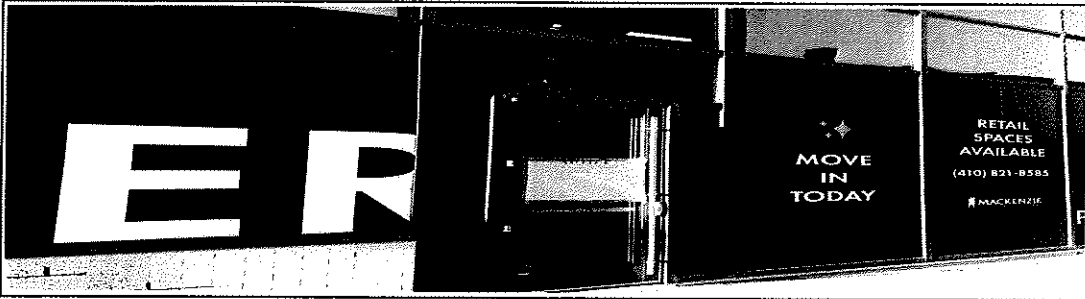

Attach Additional Photos

Approve

Disapprove

NOTICE

Application has been filed with the

Board of Liquor License Commissioners for Baltimore City

Address of Premises: 400 W. Fayette St. 21201

Class of License: BMH - Beer, Wine & Liqueur (Hotel - Motel)

Scope of Application: New Hotel - Motel License

Application filed by: Photo-FD Baltimore, LLC T/A Springhill Suites
Barbara D. Barrett and Kristopher Beck

Present Licensee(s):

The hearing concerning this application will be held on or after September 29, 2022. Persons who oppose this application should send their written protest to the office of the Board at 1 N. Charles Street, Suite 1500, Baltimore, Maryland 21201. Written protests will be acknowledged and protestants will be notified of the hearing date and time.

FOR MORE INFORMATION CALL

410-396-4377

Hon. Albert J. Marrocciani, Jr., Esq.
Aaron J. Greenfield, Esq.
Edward L. Reisinger

Chairman
Commissioner
Commissioner

Certificate of Occupancy

THIS WRITTEN INSTRUMENT, WHEN PROPERLY VALIDATED, CONSTITUTES AUTHORITY FOR DOING OR RECEIVING THE THINGS INDICATED BY THE FEES OR CHARGES SHOWN IN THE APPROPRIATE SPACES BELOW. ANY AND ALL THINGS TO BE DONE OR RECEIVED UNDER THIS WRITTEN INSTRUMENT SHALL BE DONE OR RECEIVED IN STRICT COMPLIANCE WITH THE APPLICATION HERETOFORE FILED IN THIS DEPARTMENT FOR THE AUTHORITY CONTAINED HEREIN, INCLUDING ANY AND ALL APPROVED DRAWINGS AND OTHER DATA OR INFORMATION ATTACHED THERETO, AND SUBJECT TO ANY AND ALL LAWS, ORDINANCES, RULES AND REGULATIONS IN EFFECT IN THE CITY OF BALTIMORE AND THE STATE OF MARYLAND. WARNING: IT IS UNLAWFUL TO WORK BETWEEN THE HOURS OF 7:00 PM AND 7:00 AM WITHIN 300 FEET OF A DWELLING.

WARNING: IT IS UNLAWFUL TO CONCEAL ANY WORK UNTIL INSPECTED AND APPROVED BY THIS DEPARTMENT.

WARD	SEC.	BLOCK	LOT	ISSUE DATE	DISTRICT
04	07	0618	001	12/2/21	102

PROPERTY ADDRESS: 400 W FAYETTE ST 1

OWNER: PHOTA-FD BALTIMORE LLC ADDR: 2850 QUARRY LAKE DRIVE 300 BAL

LESSEE: ADDR:

LAND USE CODES 3-31

USE BASEMENT & FIRST FLOOR AS HOTEL.

1001-000000-2600-158000-400490 PER INSP	1001-000000-2600-158000-400480 MISC.	1001-000000-2600-158000-400480 CH USE	1001-000000-2600-158000-400490 D NEW BLDG	1001-000000-2600-158000-400490 90 ADDITIONS	45.00
1001-000000-2600-158000-400490 ALTERATIONS	1001-000000-2600-158000-400490 REPAIRS	1001-000000-2600-158000-400490 MISC. CONST.	1001-000000-2600-158000-400500 ELECT	1001-000000-2600-158000-400510 HYDRONIC/STEAM HEAT	
1001-000000-2600-158000-400510 DISTRIBUTION	1001-000000-2600-158000-400510 AIR COND	1001-000000-2600-158000-400510 DISP TANKS	1001-000000-2600-158000-400510 FIRE	1001-000000-2600-158000-400510 FUEL-BURNING EQUIPMENT	
1001-000000-2600-158000-400530 ELEVATOR	1001-000000-2600-158000-400520 PLUMBING	1001-000000-2600-158000-400520 S & E CONTROL	1001-000000-2600-158000-400530 T	1001-000000-1500-102800-400230 TAX	0.00
1001-000000-2600-158000-400490 RAZING	1001-000000-2600-158000-400490 FILING FEE	1001-000000-2600-158000-400540 LOW VOLTAGE TELECOMMUNICATIONS	1001-000000-2600-158000-400480 PENALTY	TOTAL FEES	50.00
					3.00
					98.00

THE AUTHORITY CONTAINED HEREIN MAY NOT BE VALIDLY EXERCISED UNTIL AND AFTER ALL OF THE FEES APPEARING HERE HAVE BEEN PAID.

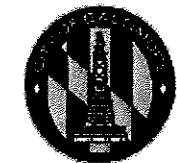

DEPARTMENT OF
HOUSING & COMMUNITY
DEVELOPMENT

Please be advised that there is a presumption of lead-based paint in properties constructed prior to 1950. Protect workers and tenants by using the lead-safe work practices found in the Code of

THE AUTHORITY CONTAINED HEREIN DOES NOT AUTHORIZE THE PERFORMANCE OF ANY WORK IN, ON, UNDER OR OVER ANY STREET, HIGHWAY, ALLEY, SIDEWALK OR ANY OTHER PUBLIC WAY, UNLESS PERMISSION TO DO SO HAS BEEN FIRST SECURED FROM THE PROPER AUTHORITY.

Certificate of Occupancy

THIS WRITTEN INSTRUMENT, WHEN PROPERLY VALIDATED, CONSTITUTES AUTHORITY FOR DOING OR RECEIVING THE THINGS INDICATED BY THE FEES OR CHARGES SHOWN IN THE APPROPRIATE SPACES BELOW ANY AND ALL THINGS TO BE DONE OR RECEIVED UNDER THIS WRITTEN INSTRUMENT SHALL BE DONE OR RECEIVED IN STRICT COMPLIANCE WITH THE APPLICATION HERETOFORE FILED IN THIS DEPARTMENT FOR THE AUTHORITY CONTAINED HEREIN, INCLUDING ANY AND ALL APPROVED DRAWINGS AND OTHER DATA OR INFORMATION ATTACHED THERETO, AND SUBJECT TO ANY AND ALL LAWS, ORDINANCES, RULES AND REGULATIONS IN EFFECT IN THE CITY OF BALTIMORE AND THE STATE OF MARYLAND. WARNING: IT IS UNLAWFUL TO WORK BETWEEN THE HOURS OF 7:00 PM AND 7:00 AM WITHIN 300 FEET OF A DWELLING.

WARNING: IT IS UNLAWFUL TO CONCEAL ANY WORK UNTIL INSPECTED AND APPROVED BY THIS DEPARTMENT.

WARD	SEC.	BLOCK	LOT	ISSUE DATE	DISTRICT
04	07	0618	001	11/26/21	102

PROPERTY ADDRESS: 400 W FAYETTE ST 1

OWNER: PHOTA-FD BALTIMORE LLC ADDR: 2850 QUARRY LAKE DRIVE 300 BAL

LESSEE: ADDR:

LAND USE CODES 3-31

USE MEZZANINE THROUGH 5TH FLOOR OF HOTEL BUILDING INCLUDING HOTEL ROOMS
201, 202, 203, 204, 205, 206, 207, 208, 209, 210, 211, 212, 213, 214, 215, 216, 217, 218, 219, 220, 301, 302,
303, 304, 305, 306, 307, 308, 309, 310, 311, 312, 313, 314, 315, 316, 317, 318, 319, 320, 401, 402, 403, 404,
405, 406, 407, 408, 409, 410, 411, 412, 413, 414, 415, 416, 417, 418, 419, 420, 501, 502, 503, 504, 505, 506,
507, 508, 509, 510, 511. (71 ROOMS)

1001-000000-2600-159600-400360 PER. INSP.	1001-000000-2600-158009-400480 MISC.	1001-000000-2600-158009-400480 CH USE	1001-000000-2600-158301-400490 NEW BLDG.	1001-000000-2600-158302-400490 ADDITIONS
		45.00		
1001-000000-2600-158302-400490 ALTERATIONS	1001-000000-2600-158304-400490 REPAIRS	1001-000000-2600-158304-400490 MISC. CONST.	1001-000000-2600-158800-400500 ELECT.	1001-000000-2600-158901-400510 HYDRONIC/STEAM HEAT
1001-000000-2600-158902-400510 DISTRIB/EXH	1001-000000-2600-158902-400510 AIR COND.	1001-000000-2600-158902-400510 DISP. TANKS	1001-000000-2600-158905-400510 FIRE	1001-000000-2600-158906-400510 FUEL-BURNING EQUIPMENT
1001-000000-2600-159300-400530 ELEVATOR	1001-000000-2600-159000-400520 PLUMBING	1001-000000-2600-159000-400520 S & E CONTROL	1001-000000-5700-508801-40181 1	1001-000000-1500-102800-400230 TAX
	0.00			3.00
1001-000000-2600-158306-400490 RAZING	1001-000000-2600-159400-400540 FILING FEE	1001-000000-2600-159400-400540 LOW VOLTAGE/TELECOMMUNICATIONS	1001-000000-2600-158009-400480 PENALTY	TOTAL FEES
	50.00			98.00

THE AUTHORITY CONTAINED HEREIN MAY NOT BE VALIDLY EXERCISED UNTIL AND AFTER ALL OF THE FEES APPEARING HERE HAVE BEEN PAID.



Please be advised that there is a presumption of lead-based paint in properties constructed prior to 1950. Protect workers and tenants by using the lead-safe work practices found in the Code of

THE AUTHORITY CONTAINED HEREIN DOES NOT AUTHORIZE THE PERFORMANCE OF ANY WORK IN, ON, UNDER OR OVER ANY STREET, HIGHWAY, ALLEY, SIDEWALK OR ANY OTHER PUBLIC WAY, UNLESS PERMISSION TO DO SO HAS BEEN FIRST SECURED FROM THE PROPER AUTHORITY.

Certificate of Occupancy

THIS WRITTEN INSTRUMENT, WHEN PROPERLY VALIDATED, CONSTITUTES AUTHORITY FOR DOING OR RECEIVING THE THINGS INDICATED BY THE FEES OR CHARGES SHOWN IN THE APPROPRIATE SPACES BELOW. ANY AND ALL THINGS TO BE DONE OR RECEIVED UNDER THIS WRITTEN INSTRUMENT SHALL BE DONE OR RECEIVED IN STRICT COMPLIANCE WITH THE APPLICATION HERETOFORE FILED IN THIS DEPARTMENT FOR THE AUTHORITY CONTAINED HEREIN, INCLUDING ANY AND ALL APPROVED DRAWINGS AND OTHER DATA OR INFORMATION ATTACHED THERETO, AND SUBJECT TO ANY AND ALL LAWS, ORDINANCES, RULES AND REGULATIONS IN EFFECT IN THE CITY OF BALTIMORE AND THE STATE OF MARYLAND. WARNING: IT IS UNLAWFUL TO WORK BETWEEN THE HOURS OF 7:00 PM AND 7:00 AM WITHIN 300 FEET OF A DWELLING.

WARNING: IT IS UNLAWFUL TO CONCEAL ANY WORK UNTIL INSPECTED AND APPROVED BY THIS DEPARTMENT.

WARD	SEC.	BLOCK	LOT	ISSUE DATE	DISTRICT
04	07	0618	001	11/26/21	102

PROPERTY ADDRESS: 400 W FAYETTE ST 1

OWNER: PHOTA-FD BALTIMORE LLC ADDR: 2850 QUARRY LAKE DRIVE 300 BAL

LESSEE: ADDR:

LAND USE CODES 3-31

USE 6TH THROUGH 12TH FLOORS OF HOTEL BUILDING INCLUDING ROOMS 601, 602, 603, 604, 605, 606, 607, 608, 609, 610, 611, 612, 613, 614, 615, 616, 617, 618, 619, 620, 701, 702, 703, 704, 705, 706, 707, 708, 709, 710, 711, 801, 802, 803, 804, 805, 806, 807, 808, 809, 810, 811, 901, 902, 903, 904, 905, 906, 907, 908, 909, 910, 911, 1001, 1002, 1003, 1004, 1005, 1006, 1007, 1008, 1009, 1010, 1011, 1101, 1102, 1103, 1104, 1105, 1106, 1107, 1108, 1109, 1110, 1111, 1201, 1202, 1203, 1204, 1205, 1206, 1207, 1208, 1209, 1210, 1211. (86 ROOMS TOTAL)

1001-000000-2600-159600-400560 PER. INSP.	1001-000000-2600-158009-400480 MISC.	1001-000000-2600-158009-400480 CH. USE	1001-000000-2600-158301-400490 NEW BLDG.	1001-000000-2600-158302-400490 ADDITIONS
		45.00		
1001-000000-2600-158302-400490 ALTERATIONS	1001-000000-2600-158304-400490 REPAIRS	1001-000000-2600-158304-400490 MISC. CONST.	1001-000000-2600-158800-400500 ELECT.	1001-000000-2600-158901-400510 HYDRONIC/STEAM HEAT
1001-000000-2600-158902-400510 DISTRIB/EXH	1001-000000-2600-158902-400510 AIR COND.	1001-000000-2600-158902-400510 DISP. TANKS	1001-000000-2600-158905-400510 FIRE	1001-000000-2600-158906-400510 FUEL-BURNING EQUIPMENT
1001-000000-2600-159300-400530 ELEVATOR	1001-000000-2600-159000-400520 PLUMBING	1001-000000-2600-159000-400520 S & E CONTROL	1001-000000-5700-508401-40181 1	1001-000000-1500-102800-400230 TAX
	0.00			3.00
1001-000000-2600-158306-400490 RAZING	1001-000000-2600-159400-400540 FILING FEE	1001-000000-2600-159400-400540 LOW VOLTAGE/TELECOMMUNICATIONS	1001-000000-2600-158009-400480 PENALTY	TOTAL FEES
	50.00			98.00

THE AUTHORITY CONTAINED HEREIN MAY NOT BE VALIDLY EXERCISED UNTIL AND AFTER ALL OF THE FEES APPEARING HERE HAVE BEEN PAID.



Please be advised that there is a presumption of lead-based paint in properties constructed prior to 1950. Protect workers and tenants by using the lead-safe work practices found in the Code of

THE AUTHORITY CONTAINED HEREIN DOES NOT AUTHORIZE THE PERFORMANCE OF ANY WORK IN, ON, UNDER OR OVER ANY STREET, HIGHWAY, ALLEY, SIDEWALK OR ANY OTHER PUBLIC WAY, UNLESS PERMISSION TO DO SO HAS BEEN FIRST SECURED FROM THE PROPER AUTHORITY.

February 9, 2023

Licensee(s): Jose Portillo and Neel Sharma
Sai Baba Hospitality, LLC, T/a El Dragon Sport Bar & Restaurant
200 S. Haven Street 21202

Class: "B" Beer, Wine & Liquor License

Violation of Rule 4.01(a) – Sales to Minors (Furnishing) – December 22, 2022 – On December 22, 2022, Board of Liquor License Commissioners ("BLLC") Agent Perez, Inspector Jordan, Inspector Tudhope, and Chief Inspector Chrissomallis, along with a member of the Baltimore Police Department Vice Unit ("BPD Vice") conducted numerous underage investigations throughout the City. Working with the BLLC and BPD Vice in an undercover capacity were BPD Cadet Degraffinried and Cadet Baerga Rodriguez, who at the time of this investigation were both under the legal drinking age of 21 years old.

At approximately 10:20pm, Cadets Degraffinried and Baerga Rodriguez entered the establishment and sat at the bar. The Cadets then ordered two (2) 12oz. Corona beer from the server who was identified as Jessica Rivera Muriel via her Maryland identification card. Once the Cadets were in possession of the two (2) 12oz. Corona beers, they informed BPD Vice and BLLC inspectors via text message that they were served alcoholic beverages and provided a physical description of the server. No money was exchanged during this transaction, instead a tab was started.

Moments later, members of the BPD Vice Unit and BLLC Inspectors entered the establishment and advised the manager, Mr. Sunil Sharma who was in full operational control of the establishment that one of his servers had furnished alcoholic beverages to underage police cadets. BPD Vice and BLLC members Ms. Rivera Muriel that she would not be criminally charged; however, a violation report would be written up for the establishment. Both agencies departed the establishment without further incident.

(a) **Service on Licensee(s):** Summons issued to the licensee(s) on 1/26/2023.

(b) **Witnesses Summoned:** Summons issued to Inspector Tudhope, Inspector Jordan, Agent Perez, and Chief Inspector Chrissomallis on 1/26/2023. Summons issued to Baltimore Police Dept.: Cadet Degraffinried and Cadet Rodriguez on 1/26/2023.

(c) **Violation History of Current Licensee:** The current corporation has no history of violations.

(d) **License Transfer Date:** The license transferred to the above named entity on 10/26/2022.

Board's Decision:

State of Maryland

Board of Liquor License Commissioners

for Baltimore City
1 N. Charles Street, Suite 1500
Baltimore, Maryland, 21201-3724
Phone: (410) 396-4377

NOTICE

To: SAI BABA HOSPITALITY, LLC
t/a El Dragon Sport Bar & Restaurant
200 Haven Street South, 21224

Date: January 26, 2023

**Licensee may be represented by
Counsel before board**

You are hereby notified to appear before the Board of Liquor License Commissioners for Baltimore City at 10:30 o'clock AM on the 9th day of February 2023, at **City Hall, 100 North Holliday Street, Room 215, Baltimore, MD 21202**, to show cause why your Alcoholic Beverages License and other permits issued by this Board to you under the provisions of the Alcoholic Beverages Article, as amended, should not be suspended or revoked as required by this Board by Section 4-604 of said Article, following your conviction and/or violation of said law, to wit:

Location of Incident: t/a 200 Haven Street South 21224 ("the establishment").

Violation of Rule 4.01(a) – Sales to Minors (Furnishing) – December 22, 2022 – On December 22, 2022, Board of Liquor License Commissioners ("BLLC") Agent Perez, Inspector Jordan, Inspector Tudhope, and Chief Inspector Chrissomallis, along with a member of the Baltimore Police Department Vice Unit ("BPD Vice") conducted numerous underage investigations throughout the City. Working with the BLLC and BPD Vice in an undercover capacity were BPD Cadet Degraffinried and Cadet Baerga Rodriguez, who at the time of this investigation were both under the legal drinking age of 21 years old.

At approximately 10:20pm, Cadets Degraffinried and Baerga Rodriguez entered the establishment and sat at the bar. The Cadets then ordered two (2) 12oz. Corona beer from the server who was identified as Jessica Rivera Muriel via her Maryland identification card. Once the Cadets were in possession of the two (2) 12oz. Corona beers, they informed BPD Vice and BLLC inspectors via text message that they were served alcoholic beverages and provided a physical description of the server. No money was exchanged during this transaction, instead a tab was started.

Moments later, members of the BPD Vice Unit and BLLC Inspectors entered the establishment and advised the manager, Mr. Sunil Sharma who was in full operational control of the establishment that one of his servers had furnished alcoholic beverages to underage police cadets. BPD Vice and BLLC members Ms. Rivera Muriel that she would not be criminally charged; however, a violation report would be written up for the establishment. Both agencies departed the establishment without further incident.

If you fail to appear at the above location at the date and time as instructed by the agency, the Board will proceed with the hearing and will take such action regarding the suspension or revocation of your license and permits as warranted by evidence. If you have any questions concerning the specific rules or code cited, please refer to Rules and Regulations for the Board of Liquor License Commissioners for Baltimore City or the Alcoholic Beverages Article of the Annotated Code of Maryland for reference purposes. If you have any questions or concerns regarding this matter please contact Deputy Executive Secretary, Nicholas T.R. Blendy, at 410-396-4377.

**BY ORDER OF THE BOARD OF LIQUOR LICENSE
COMMISSIONERS FOR BALTIMORE CITY**

Albert Matricciani, Jr., Chairman

**BOARD OF LIQUOR LICENSE
COMMISSIONERS
FOR BALTIMORE CITY**

Board of Liquor License Commissioners

For Baltimore City
1 North Charles Street, 15th Floor
Baltimore, Maryland, 21201

VIOLATION REPORT

<i>Location Address:</i>	200 HAVEN STREET SOUTH 21224	
<i>Licensee Information (Trade Name):</i>	EL DRAGON SPORT BAR & RESTAURANT	
<i>Corporation Name</i>	SAI BABA HOSPITALITY, LLC	
<i>License Type:</i>	Class "B" Beer, Wine and Liquor	
<i>Contact:</i>	Sunil Sharma	
<i>Bouncer/Security Name (if applicable):</i>	<input type="text"/>	D.O.B. <input type="text"/>
<i>Date Violation Issued:</i>	<input type="text" value="12/22/2022"/>	<input type="text" value="10:20:00 PM"/>

Violation Reporting Facts:

On December 22, 2022 I, Agent Perez, Inspector Jordan, Inspector Tudhope and Chief Inspector Chrissomallis from the BLLC along with a member of BPD Vice conducted numerous underage investigations throughout the city. Working with our two agencies in an undercover capacity were Cadets Degraffinried and Cadet Baerga Rodriguez, who at the time of this investigation were under the legal drinking age of 21.

At approximately 10.20PM, Cadets Degraffinried and Baerga Rodriguez entered the establishment known as El Dragon Sport Bar & Restaurant located at 200 S. Haven St. and sat at the bar. The Cadets then proceeded to order (2) 12oz Corona beer from the server who was later identified as Jessica Rivera Muriel via her MD identification card. Once the Cadets were in possession of the (2) 12oz Corona beer, they informed the team via text message that they were served alcoholic beverages and provided a physical description of the server. No money was exchanged during this transaction, instead a tab was started.

Moments later, members of the BPD Vice Unit and BLLC entered the establishment and advised the manager Mr. Sunil Sharma who was in full operational control of the establishment that one of his server had furnished alcoholic beverages to the underage police cadets.

BPD vice and BLLC members informed Miss Rivera Muriel that she would not be criminally charged however a violation report would be written up for the establishment. Both agencies departed the establishment without further incident.

Photos Taken:





Report Prepared By:

Inspector(s)

Submission Date

i:\0#.w\|baltimore\andy.perez

12/30/2022



Liquor Board System

Version 1.0

Annual-Renewal ▾ | License-Transfer ▾ | One-Day ▾ | Add New License ▾ | Query ▾

License Detail

Close the License

Print License

Print Renewal Letter

<< Go Back

License Info

License Num: **LB 143**

Cert Num: **T0752**

Fee: **\$200.00**

Status: **Transferred**

License Date: 10/26/2022 3:54:39 PM License Year: 2022

CR Number: 19269919

Payment Date: 05-03-22

2021 - 2022 TPP Paid Y

2022 Trader's License Y

Update Info

Click to Start License Renewal

Add Adult Entertainment License

Add New Adult Entertainment License

Location

Corp Name: **SAI BABA HOSPITALITY, LLC**

Trade Name: **EL DRAGON SPORT BAR & RESTAURANT**

Zone Code: 11

Phone: 443-854-6217

Block Num: 200

City: BALTIMORE

Street: HAVEN STREET SOUTH

State: MD

Zip: 21224

CR Number: 19269919

Portion of Business Used:

CONTINUE TO USE PREMISES AS A TAVERN AND RESTAURANT.

Restriction:

THE MOU DATED ON MAY 25TH 2022 BETWEEN HIGHLANDTOWN COMMUNITY ASSOCIATION AND THE LICENSEE IS INCORPORATED INTO THE LICENSE.

Edit the License Location Info

Alternate Mailing Address

License Owners

First Name	Last Name	Street	City	State	Zip	Action	Change Owner
JOSE	PORTILLO	624 N. BELNORD AVENUE	BALTIMORE	MD	21205	Edit	Remove Owner
NEEL	SHARMA	4109 WESTMEATH ROAD	BALTIMORE	MD	21236	Edit	Remove Owner

Comments

Date	Comment	Action
10/26/2022	Alcohol Awareness expires on 06/28/2023; SUNIL SHARMA (certified by John S. Murray)..../sb	Delete
10/26/2022	licensee returned old license.	Delete
10/26/2022	TRANSFER COMPLETED & ISSUED Application for Transfer of Ownership issued to SAI BADA HOSPITALITY, LLC t/a EL DRAGON SPORT BAR & RESTAURANT, JOSE PORTILLO and NEEL SHARMA on OCTOBER 26, 2022; see Invoice #127403.../sb	Delete
10/05/2022	90 Day pending Transfer letter sent to all listed applicant's and attorneys on 10/05/2022...k/r	Delete
08/05/2022	PAID IN FULL \$225.00 for Violation Hearing dated July 14, 2022; Invoice #126937..../sb	Delete
08/03/2022	7/28/2022 - Public Hearing Re: Violation of Rule 4.05 Prohibited Hours - Rule 4.05-fined \$100; \$100 + \$125 admin fee = \$225 total fine, 30 days to pay (3-0 vote) **Must submit an operational plan to the Chief Inspector in 2 weeks**...../jr	Delete
06/10/2022	6/9/2022 - Public Hearing Re: Application to transfer ownership requesting delivery of alcoholic beverages - APPROVED (3-0 vote) *MOU to be made a part of the license*..../jr	Delete
06/08/2022	Mailed letter of recognition for underage drinking compliance check on 5/26/2022 /kk	Delete
04/14/2022	4/14/2022 - Virtual Public Hearing Re: Application to transfer ownership requesting delivery of alcoholic beverages - POSTPONED.../jr	Delete
03/30/2022	FOOD FORM WAS SUBMITTED WITH 2022-2023 RENEWAL APPLICATION..... /sb	Delete
03/07/2022	Application for transfer of ownership requesting delivery of alcoholic beverages filed on behalf of Sai Baba Hospitality, LLC T/a Trade Name Pending, Neel Sharma and Jose Portillo on 2/28/2022 /kk	Delete
01/27/2022	1/27/2022- received letter from BCHD stating that the Health Permit will be REVOKED on Feb. 4, 2022 until further notice. Per J. Chrissomallis (Chief Inspector)	Delete
03/17/2021	03/17/2021 - Processed 2021-2022 Renewal Application; Invoice #120439..../sb	Delete
02/19/2020	Alcohol Awareness expires on 02/09/24 Heydy R. Cruz Banegas (certified by John S Murray)..../sb	Delete
02/11/2020	Sent 90-day admin letter to licensee(s) regarding closed inspections and to follow up with the BLLC /kk	Delete
10/29/2019	The Business is cleared from Hold as per the e-mailed received from Law Department on October 29,2019.../mb	Delete
09/26/2019	Personal Property tax letter mailed to Licensee(s) Home Address on 09/26/19..... /sb	Delete
08/14/2019	Submitted 2019 Trader's License..... /sb	Delete
07/17/2019	PAID IN FULL FOR Insufficient Funds of Liquor Board Fine from 05/23/19: Invoice #117566 = \$1,625.00 + Invoice # 117567 = \$30.00..... /sb	Delete
07/16/2019	Violation Fine Fee \$1,625.00 paid on 06/21/19 was returned back due to "Closed Account". Ms. Branch informed Mr. George to bring two separate cashier check/money order with the amount of \$1,625.00 and \$30.00/mb	Delete
06/28/2019	5/23/2019 - Public Hearing Re: Violation of Rule 4.01(a) Sales to Minors - ADMISSION OF GUILT - Rule 4.01(a)-Fined \$1,500; \$1,500 + \$125 admin fee; \$1,625 total fine, 30 days to pay (3-0 vote)...../jr	Delete
06/24/2019	Violation PAID IN FULL hearing dated 05/23/2019. Please check invoice #117044...k/r	Delete
05/02/2019	*****RELEASED STATE OF MD TAX HOLD***** /sb	Delete
04/02/2019	FOOD FORM WAS SUBMITTED WITH 2019-2020 RENEWAL APPLICATION..... /sb	Delete
01/25/2019	***STATE OF MD TAX HOLD, letter sent to Licensee's Business Address on January 25, 2019.***/mb	Delete
12/27/2018	Alcohol Awareness expires on 12/19/22 (Maria D. Rodriguez, Franklin Guevara, Lidia Granados and Edgardo I. Ramierz) John S. Murray.... /sb	Delete
10/04/2018	Food Form compliance warning letter was sent to licensee on 10/3/2018...../jr	Delete
10/02/2018	*****Paid in Full... Please Check Invoice #113518 *****8/30/2018 - Public Hearing RE: Violation of Rule 4.01(a) Sales to Minors and Violation of Rule 3.03(c) Records - ADMISSION OF GUILT - Rule 4.01(a)-Fined \$700; Rule 3.03(c)-Fined \$500; \$1,200 + \$125 admin fee = \$1,325 total fine; 30 days to pay (2-1 vote)...../kr	Delete
09/18/2018	Given an Invoice to Inspector John Howard for Violation Hearing fee dated on August 30, 2018; Fine Fee to be paid for \$1,325.00.... /mb.	Delete

09/04/2018	8/30/2018 - Public Hearing RE: Violation of Rule 4.01 (a) Sales to Minors and Violation of Rule 3.03(c) Records - ADMISSION OF GUILT - Rule 4.01 (a)-Fined \$700; Rule 3.03(c)-Fined \$500; \$1,200 + \$125 admin fee = \$1,325 total fine; 30 days to pay (2-1 vote)...../jr	Delete
07/30/2018	7/26/2018 - Public Hearing RE: Violation of Rule 4.01 (a) Sales to Minors and Violation of Rule 3.03(c) Records - POSTPONED...../jr	Delete
04/26/2018	04-26-18 - Per Health Dept, Mr. Jerry Welch advise us to hold the Liquor License because their Health Permit expired...../sb	Delete
03/29/2018	2018-2019 FOOD FORM WAS DROPPED OFF IN OFFICE.... /sb	Delete
03/22/2018	PAID IN FULL for Violation Hearing dated February 15, 2018....Invoice #110064.... /sb	Delete
03/06/2018	Given an Invoice to Chief Inspector M. Fosler for Violation Hearing fee dated on February 15, 2018; Fine Fee to be paid \$2,125.00.... /mb.	Delete
03/06/2018	The electrical work was signed off by the electrical inspector on 3/5/2018. They are clear on the housing side.	Delete
03/01/2018	2/15/2018 - Public Hearing RE: Violation of Rule 3.08(a) and Violation of Rule 3.09(b) - GUILTY - Rule 3.08(a) fined \$1,000, Rule 3.09(b) Fined \$1,000 = \$2,000 + \$125 admin fee for a \$2,125 total fine, 30 days to pay - Suspended until cleared by the Baltimore City Housing Department - Commencing Immediately (3-0 Vote)...../jr	Delete
02/20/2018	02-20-18 - Return To Sender; Vacant; Unable To Forward.... /sb	Delete
02/16/2018	2/15/2018 - Public Hearing RE: Violation of Rule 3.08(a) and Violation of Rule 3.09(b) - GUILTY - Rule 3.08(a) fined \$1,000, Rule 3.09(b) Fined \$1,000 = \$2,000 + \$125 admin fee for a \$2,125 total fine, 30 days to pay - Suspended until cleared by the Baltimore City Health Department - Commencing Immediately (3-0 Vote)...../jr	Delete
02/09/2018	Re-send 2018-2019 Renewal Application to Licensee home address.... /sb	Delete
02/09/2018	02-08-18 - Returned To Sender; Not Deliverable As Addressed; Unable To Forward.... /sb	Delete
05/10/2017	2017 Food Form was Submitted.... /sb	Delete
10/28/2016	FOOD FORM WAS ATTACHED TO 2016 RENEWAL APPLICATION...K/R	Delete
09/13/2016	Letter sent on 9/2/2016 in reference to 2016 food form submission. Establishment had 10 days from that date of letter to submit the form. At this time there has been no response....k.r	Delete
04/01/2016	*****RELEASED STATE TAX HOLD.... /sb*****	Delete
01/20/2016	Alcohol Awareness Training (Blanca Peaquera Avalos) expires 12/30/2019 John S Murray	Delete
11/25/2015	Licensee came in a PAID \$1,125.00 FINE FROM HEARING DATED ON OCTOBER 08, 2015, Invoice #100054 = \$500.00 & #100055 = \$625.00... /sb	Delete
10/29/2015	Sent letter for past due violation fee \$31,125.00; hearing date 10/08/15.	Delete
10/13/2015	10/8/2015 Public Hearing Violation 3.03(c) (GUILTY \$500) Violation of Rule 4.02 (GUILTY \$1500) Violation of Rule 3.12 Public Welfare DISMISSED \$1125 Total Fine **14 days to pay	Delete
05/05/2015	05/05/2015-\$625.00 fine from September 4, 2014 paid in full	Delete
04/02/2015	RELEASED STATE OF MD TAX HOLD ON 03/30/15.../sb	Delete
02/03/2015	State of MD Tax Hold, letter sent to merchant on January 23, 2015.	Delete
11/17/2014	10/7/2014 Public Hearing re: Violation Rule 4.18 POSTPONED	Delete
09/05/2014	09/4/2014 Public Hearing re Violations of Rule 4.18 (Providing Live Entertainment without Board's approval)Guilty \$250 Violations of Rule 4.18 (Providing Live Entertainment without Board's approval) Guilty \$250 + Admin Fee \$125= Total \$625 (30 days to Pay)	Delete
07/29/2014	07/24/14 Public Hearing re: Violation of Rule 4.18 (re April 26,2014 police officer observed 40-50 individuals dancing in the establishment , liquor license states "NO Live Entertainment or Dancing") Request from licensee for postponement until August 7, 2014 to obtain representation on this matter.GRANTED	Delete
02/15/2013	2/14/2013 Public Hearing re: VIOLATION of Article 2Bsection10-505 Liquor license not displayed. VIOLATION of Rule 4.18 Illegal conduct (live entertainment without board approval). VIOLATION of Rule 3.06 Health, Fire, Building Code (side exit door locked). Article 2Bsection10-505 GUILTY \$25. Rule 4.18 GUILTY \$200. Rule 3.06 GUILTY \$775. TOTAL FINE \$1000	Delete
02/27/2012	2/23/2012 Public Hearing re: VIOLATION of Rule 3.06 Health department violation. VIOLATION of Rule 4.01 (a) Sale to minor, VIOLATION of Atricle 2Bsection 12-108(d) Underage possession. VIOLATION of Rule 4.20(a)Alterations without Board permission. VIOLATION of Rule 4.20(b)Alterations without City Permits. RULE 3.06 DISMISSED. RULE 4.01 (a)and ARTICLE 2Bsection 12-108(d) DISMISSED. RULE 4.20(a) GUILTY \$250. RULE 4.20(b) GUILTY No fine. TOTAL FINE \$250	Delete
08/18/2011	8/11/11 Public Hearing re: Application to transfer ownership of license presently in the name of Mary Lou Scardina, M&L Scardina Inc, t/a Enrico's Sports Bar & Cafe where establishment has	Delete

	been closed for more that 90 days, application includes a request for live entertainment. BOARD APPROVED TRANSFER.	
07/11/2011	7/11 Transfer of ownership with request for live entertainment, B-BWL restaurant license, Luis F. George, Luis Pineda, Two Loueys Cantina, LLC	Delete
03/01/2004	12/4/97 Public hearing re: Application for a new Class "B" BWL restaurant license under the provisions of Rule 2.08 requiring a \$200,000 capital investment & seating capacity for 75 persons APPROVED	Delete

[Print History \(Print Card\)](#)

License num: LB 143 Address: 200 HAVEN STREET SOUTH
Trade Name: EL DRAGON SPORT BAR & RESTAURANT

Comment:

[Add Comment](#)

Hold Info



SAI BABA HOSPITALITY, LLC: W22625255

Department ID Number:

W22625255

Business Name:

SAI BABA HOSPITALITY, LLC

Principal Office: ⓘ

200 S. HAVEN STREET
BALTIMORE MD 21224

Resident Agent: ⓘ

PARI SHARMA
4109 WESTMEATH ROAD
NOTTINGHAM MD 21236

Status:

ACTIVE

Good Standing:

THIS BUSINESS IS IN GOOD STANDING

Business Type:

DOMESTIC LLC

Business Code:

20 ENTITIES OTHER THAN CORPORATIONS

Date of Formation/ Registration:

02/07/2022

State of Formation:

MD

Stock Status:

N/A

Close Status:

N/A

February 9, 2023

Licensee(s): Peter Bramble
Y56 BWA Operator, LLC., T/a Fleet Street Spirits
5601 Eastern Avenue k/a 5701A Fleet Street 21224

Class: "A-7" Beer, Wine & Liquor License

Violation of Rule 4.01(a) – Sales to Minors – December 22, 2022 – On December 22, 2022, Board of Liquor License Commissioners ("BLLC") Inspector Jordan, Inspector Tudhope, and Chief Inspector Chrissomallis, along with Detective Gatto of the Baltimore Police Department Vice Unit ("BPD Vice") conducted numerous underage investigations throughout the City. Working with the BLLC and BPD Vice in an undercover capacity were BPD Cadet Degraffinried and Cadet Baerga Rodriguez, who at the time of this investigation were both under the legal drinking age of 21 years old. Prior to the investigation, a departmental \$20 bill was photographed to be traced as the cash used to purchase.

At approximately 9:40pm, Cadets Degraffinried and Baerga Rodriguez entered the establishment. At this time, the Cadets were successful in purchasing a six (6) pack of Medalla Light Beer for \$7.99, using the \$20 bill. Following the purchase, the Cadets exited the establishment carrying the alcoholic beverages. Members of BPD Vice and the BLLC then entered the establishment and made contact with the seller, who identified herself as Diana Melgar, verified by her identification. BPD Vice and BLLC members informed Ms. Melgar that she had sold alcohol to underage police cadets. The alcoholic beverages and change were returned to the establishment and the departmental \$20 bill was recovered. BPD Vice Unit and BLLC members informed Ms. Melgar Patel that she would not be criminally charged; however, a violation report would be written up for the establishment. Both agencies departed the establishment with no further incident.

(a) **Service on Licensee(s):** Summons issued to the licensee(s) on 1/26/2023.

(b) **Witnesses Summoned:** Summons issued to Inspector Tudhope, Inspector Jordan, Agent Perez, and Chief Inspector Chrissomallis on 1/26/2023. Summons issued to Baltimore Police Dept.: Cadet Degraffinried and Cadet Rodriguez on 1/26/2023.

(c) **Violation History of Current Licensee:** The current corporation has no history of violations.

(d) **License Transfer Date:** The license transferred to the above named entity on 6/30/2020.

Board's Decision:

State of Maryland

Board of Liquor License Commissioners

for Baltimore City
1 N. Charles Street, Suite 1500
Baltimore, Maryland, 21201-3724
Phone: (410) 396-4377

NOTICE

To: Y56 BWA Operator, LLC
t/a Fleet Street Spirits
5601 Eastern Avenue k/a 5701A Fleet Street, 21224

Date: January 26, 2023

**Licensee may be represented by
Counsel before board**

You are hereby notified to appear before the Board of Liquor License Commissioners for Baltimore City at 10:30 o'clock AM on the 9th day of February 2023, at **City Hall, 100 North Holliday Street, Room 215, Baltimore, MD 21202**, to show cause why your Alcoholic Beverages License and other permits issued by this Board to you under the provisions of the Alcoholic Beverages Article, as amended, should not be suspended or revoked as required by this Board by Section 4-604 of said Article, following your conviction and/or violation of said law, to wit:

Location of Incident: t/a Fleet Street Spirits, 5601 Eastern Avenue k/a 5701A Fleet Street 21224 ("the establishment").

Violation of Rule 4.01(a) – Sales to Minors – December 22, 2022 – On December 22, 2022, Board of Liquor License Commissioners ("BLLC") Inspector Jordan, Inspector Tudhope, and Chief Inspector Chrissomallis, along with Detective Gatto of the Baltimore Police Department Vice Unit ("BPD Vice") conducted numerous underage investigations throughout the City. Working with the BLLC and BPD Vice in an undercover capacity were BPD Cadet Degraffinried and Cadet Baerga Rodriguez, who at the time of this investigation were both under the legal drinking age of 21 years old. Prior to the investigation, a departmental \$20 bill was photographed to be traced as the cash used to purchase.

At approximately 9:40pm, Cadets Degraffinried and Baerga Rodriguez entered the establishment. At this time, the Cadets were successful in purchasing a six (6) pack of Medalla Light Beer for \$7.99, using the \$20 bill. Following the purchase, the Cadets exited the establishment carrying the alcoholic beverages. Members of BPD Vice and the BLLC then entered the establishment and made contact with the seller, who identified herself as Diana Melgar, verified by her identification. BPD Vice and BLLC members informed Ms. Melgar that she had sold alcohol to underage police cadets. The alcoholic beverages and change were returned to the establishment and the departmental \$20 bill was recovered. BPD Vice Unit and BLLC members informed Ms. Melgar Patel that she would not be criminally charged; however, a violation report would be written up for the establishment. Both agencies departed the establishment with no further incident.

If you fail to appear at the above location at the date and time as instructed by the agency, the Board will proceed with the hearing and will take such action regarding the suspension or revocation of your license and permits as warranted by evidence. If you have any questions concerning the specific rules or code cited, please refer to Rules and Regulations for the Board of Liquor License Commissioners for Baltimore City or the Alcoholic Beverages Article of the Annotated Code of Maryland for reference purposes. If you have any questions or concerns regarding this matter please contact Deputy Executive Secretary, Nicholas T.R. Blendy, at 410-396-4377.

BY ORDER OF THE BOARD OF LIQUOR LICENSE
COMMISSIONERS FOR BALTIMORE CITY

Albert Matricciani, Jr., Chairman

BOARD OF LIQUOR LICENSE
COMMISSIONERS
FOR BALTIMORE CITY

Board of Liquor License Commissioners

For Baltimore City
1 North Charles Street, 15th Floor
Baltimore, Maryland, 21201

VIOLATION REPORT

Location Address:	5601 EASTERN AVENUE K/A 5701A FLEET STREET 21224	▼
Licensee Information (Trade Name):	FLEET STREET SPIRITS	
Corporation Name	Y56 BWA OPERATOR, LLC	
License Type:	Class "BD7" Beer, Wine and Liquor	▼
Contact:		
Bouncer/Security Name (if applicable):		D.O.B. <input type="text"/>
Date Violation Issued:	12/22/2022	9:42:00 PM

Violation Reporting Facts:

On December 22, 2022 I, Inspector Jordan, Inspector Tudhope and Chief Inspector Chrissomallis from the BLLC along BPD Vice Unit Detective Gatto conducted numerous underage drinking investigations. Working with our two agencies in an undercover capacity were Cadets Degraffinried and Baerga Rodriguez, who at the time of this investigation were under the legal drinking age of 21. Prior to the investigation, a departmental \$20 bill was photographed so it could later be traced as the cash utilized to make the purchase.

At approximately 09:40PM, the Cadets entered the establishment known as FLEET STREET SPIRITS located at 5601 Eastern Avenue 21214. At this time, the Cadets were successful in purchasing a six pack of Medalla Light beer for a total of \$7.99 utilizing the departmental \$20 bill.

Following the purchase, the Cadets exited the establishment carrying the alcoholic beverage. BPD Vice Unit and BLLC subsequently entered the establishment and made contact with the seller who identified herself as Diana Melgar DOB 10/01 as verified by her identification. BPD Vice Unit and BLLC informed Ms, Melgar that she had sold alcohol to underage police Cadets. The alcoholic beverage and change was returned to the establishment and the departmental \$20 bill was recovered

BPD Vice Unit and BLLC members informed Ms. Melgar that she would not be criminally charged however a violation report would be written up for the establishment. Both agencies departed the establishment without further incident.

Photos Taken:





Attach Additional Photos

Report Prepared By:

Inspector(s)

Submission Date

i:\0#.w\|baltimore\rosalba.jordan

12/29/2022

~~Approve~~

Disapprove



Liquor Board System

Version 1.0

Annual-Renewal | License-Transfer | One-Day | Add New License | Query

License Detail

Close the License | Print License | Print Renewal Letter | << Go Back

License Info

License Num: **LBD7 278** Cert Num: **0653** Fee: **\$1,500.00** Status: **Renewed**
License Date: 5/1/2022 License Year: 2022
CR Number: 18183623
Payment Date: 04-26-22

2021 - 2022 TPP Paid
2022 Trader's License [Update Info](#)

[Click to Start License Renewal](#)

Add Adult Entertainment License

[Add New Adult Entertainment License](#)

Location

Corp Name: **Y56 BWA OPERATOR, LLC**
Trade Name: **FLEET STREET SPIRITS**
Zone Code: 12
Phone: 410-662-0105

Block Num: 5601 Street: EASTERN AVENUE K/A 5701A FLEET STREET
City: BALTIMORE State: MD Zip: 21224

CR Number: 18183623

Portion of Business Used:

TO USE A PORTION OF THE PREMISES KNOWN AS 5701A FLEET STREET AS RETAIL GOODS ESTABLISHMENT WITH ALCOHOLIC BEVERAGE SALES PER PUD ORD 18-175 AND ACCESSORY TASTING AREA

Restriction:

Under Alc. Bev. Art. 12-902.1, the licensee(s) meet the requirements of issuance for this Class A-7 license as: (1) the Class BD7 license for this location was issued prior to July 1, 2018; and (2) licensee(s) obtained approval by resolution of the Baltimore City Council on September 4, 2020.

[Edit the License Location Info](#) [Alternate Mailing Address](#)

License Owners

First Name	Last Name	Street	City	State	Zip	Action	Change Owner
PETER	BRAMBLE	1800 MADISON AVENUE	Baltimore	MD	21217	Edit	Remove Owner

Comments

Date	Comment	Action
04/12/2022	Renewed for 2022 - License Number A-7 012 /kk	Delete
04/13/2021	Application for transfer of ownership issued to corporation. t/a Fleet Street Spirits Peter Warren David Bramble on 4/13/2021; see invoice # 121183...k/r	Delete
04/07/2021	****Processed 2021-2022 Renewal Application; Invoice #120977...../sb***	Delete
09/10/2020	9/10/20- Virtual Hearing- Application to transfer location of a Class "BD7" Beer, Wine & Liquor License presently located at 5601 Eastern Avenue k/a 517 Bayview Boulevard to 5601 Eastern Avenue k/a 5701 A Fleet Street.- Approved - S.R	Delete
09/09/2020	Application for transfer of location of a Class "BD7" License presently located at 5601 Eastern Avenue k/a 517 Bayview Boulevard to 5601 Eastern Avenue k/a 5701A Fleet Street filed on behalf of Y56 BWA Operator, LLC T/a Trade Name Pending, Peter Warren David Bramble on 7/27/2020 (August 2020 Ad) /kk	Delete
09/04/2020	New License issued which changes operating hours due to HB1293/SB69 that specifies privileges hereby granted may be exercised at any time from 10 a.m. to 12 a.m. daily effective July 1, 2020. see invoice # 119961...../KR	Delete
06/30/2020	Application for transfer of ownership issued to Y56 BWA Operator, LLC T/a Trade Name Pending, Peter Warren David Bramble on 6/30/2020;SEE INVOICE# 119839 ...K/R	Delete
06/30/2020	APPLICATION FORTRANSFER OF OWENRSHIP ISSUED TO Y56 BWA Operator, LLC T/a Trade Name Pending, Peter Warren David Bramble ON 6/30/2020;SEE INVOICE# 119839 ...K/R	Delete
06/05/2020	6/4/2020 - Virtual Public Hearing Re: Application to transfer ownership and location of a Class "BD7" BWL presently located at 3607 Fleet Street to 5601 Eastern Avenue AKA 517 Bayview Boulevard - APPROVED (3-0 vote)..../jr	Delete
05/11/2020	Application for transfer of ownership and located of a Class "BD7" BWL presently located at 3607 Fleet Street to 5601 Eastern Avenue AKA 517 Bayview Boulevard filed on behalf of Y56 BWA Operator, LLC T/a Trade Name Pending, Peter Warren David Bramble on 5/7/2020 /kk	Delete
06/28/2019	Due to the ransomware attack that effected City Servers on 5/7/2019, the BLLC was not able to enter 2018 license payment information until today's date; Invoice #117379...../jr	Delete
11/28/2018	Personal Property tax letter not mailed to Licensee(s) because the transfer is pending.../mb	Delete
12/02/2016	SUSPENSION NOTICE HAS BEEN ISSUED AND PLACED ON BUILDING UNTIL FURTHER NOTICE..... /sb	Delete
11/28/2016	11/25/16 - Sent letters to Licensee home address about "Personal Property Tax Owed to the City of Baltimore".... /sb	Delete
11/25/2016	Mail was labeled "Return To Sender" - No Such Number - Unable to Forward... /sb	Delete
11/15/2016	11/15/16 - Mailed letter to Licensee about "Personal Property Tax Owed to the City of Baltimore".... /sb	Delete
08/17/2016	Mail was returned "Return to Sender Vacant Unable to Forward"	Delete
07/26/2016	07/25/16 - Mailed letter to Licensee about "Personal Property Tax Owed to the City of Baltimore".... /sb	Delete
02/12/2015	PAID \$100.00 FEE FOR HEARING DATED 02/12/15, INVOICE #95720.	Delete
10/31/2012	10/18/2012 Public Hearing re: VIOLATION of Rule 4.18 Illegal Conduct: Corporate charter not in good standing. Submitted documentation, paid fine in lieu of hearing. TOTAL FINE \$125.	Delete
05/20/2008	03/28/07 \$1525 FINE PAID IN FULL #58682	Delete
03/28/2007	03/22/07 Public Hearing re: Violation of Rule 4.01(a), Rule 3.03(c), Rule 4.18 DECISION: GUILTY \$1200, 3.03(C) GUILTY \$100, 4.18 GUILTY \$100 + \$125 ADM FEE=1525	Delete
12/23/2005	12/21/05 APPLICATION TO TRANSFER OWNERSHIP DECISION: APPROVED	Delete
12/23/2005	12/21/05 FINE \$425 PAID IN FULL # 54704	Delete
12/16/2005	12/15/05 Public Hearing re: Violation of rule 4.01(a). DECISION: GUILTY \$500/SUSPENDED \$200. FINE \$300 OR 3 DAYS + \$125 ADM.FEE =\$425	Delete
03/01/2004	2/10/2000 Public Hearing re: Application to transfer ownership i of Class BD7 license presently in the name of Anthony i Paszkiewicz, Secured Creditor for Albert Tarquinio, Side Pocket, i Inc. t/a Side Pocket Inn, to the the applicants at the same i location APPROVED	Delete

Print History (Print Card)

License num: LBD7 278

Address: 5601 EASTERN AVENUE K/A 5701A FLEET STREET

Trade Name: FLEET STREET SPIRITS

Y56 BWA OPERATOR LLC: W19091586

Department ID Number:

W19091586

Business Name:

Y56 BWA OPERATOR LLC

Principal Office: 

2002 CLIPPER PARK ROAD

SUITE 105

BALTIMORE MD 21211

Resident Agent: 

P. DAVID BRAMBLE

2002 CLIPPER PARK ROAD

SUITE 105

BALTIMORE MD 21211

Status:

ACTIVE

Good Standing:

THIS BUSINESS IS IN GOOD STANDING

Business Type:

DOMESTIC LLC

Business Code:

20 ENTITIES OTHER THAN CORPORATIONS

Date of Formation/ Registration:

09/12/2018

State of Formation:

MD

Stock Status:

N/A

Close Status:

N/A

February 9, 2023

Licensee(s): Bhaveshkumar Patel
Mesva, Inc., T/a New Food Way
1501 Broening Highway 21224

Class: "A" Beer & Wine License

Violation of Rule 4.01(a) – Sales to Minors – December 22, 2022 – On December 22, 2022, Board of Liquor License Commissioners ("BLLC") Inspector Tudhope, Inspector Jordan, Agent Perez, and Chief Inspector Chrissomallis, along with a member of the Baltimore Police Department Vice Unit ("BPD Vice") conducted numerous underage investigations throughout the City. Working with the BLLC and BPD Vice in an undercover capacity were BPD Cadet Degraffinried and Cadet Baerga Rodriguez, who at the time of this investigation were both under the legal drinking age of 21 years old.

At approximately 9:15pm, Cadets Degraffinried and Baerga Rodriguez entered the establishment. At this time, the Cadets were successful in purchasing two (2) 23.5 oz. cans of Sour Grape Four Loko for \$7.40, using the \$20 bill provided to them to make purchases. Following the purchase, Cadets Degraffinried and Baerga Rodriguez exited the establishment carrying the alcoholic beverage. Members of BPD Vice and the BLLC then entered the establishment and made contact with the seller, who identified himself as Sanjaykumar Manilal Patel, verified by his Maryland driver's license. BPD Vice and BLLC members informed Mr. Patel that he had sold alcohol to underage police cadets. The alcoholic beverages and change were returned to the establishment and the departmental \$20 bill was recovered. BPD Vice Unit and BLLC members informed Mr. Patel that he would not be criminally charged; however, a violation report would be written up for the establishment. Both agencies departed the establishment with no further incident

(a) **Service on Licensee(s):** Summons issued to the licensee(s) on 1/26/2023.

(b) **Witnesses Summoned:** Summons issued to Inspector Tudhope, Inspector Jordan, Agent Perez, and Chief Inspector Chrissomallis on 1/26/2023. Summons issued to Baltimore Police Dept.: Cadet Degraffinried and Cadet Rodriguez on 1/26/2023.

(c) **Violation History of Current Licensee:** The current corporation has no history of violations.

(d) **License Transfer Date:** The license transferred to the above named entity in 2016.

Board's Decision:

State of Maryland

Board of Liquor License Commissioners

for Baltimore City
1 N. Charles Street, Suite 1500
Baltimore, Maryland, 21201-3724
Phone: (410) 396-4377

NOTICE

To: MESVA, INC.
t/a New Food Way
1501 Broening Highway, 21224

Date: January 26, 2023

**Licensee may be represented by
Counsel before board**

You are hereby notified to appear before the Board of Liquor License Commissioners for Baltimore City at 10:30 o'clock AM on the 9th day of February 2023, at **City Hall, 100 North Holliday Street, Room 215, Baltimore, MD 21202**, to show cause why your Alcoholic Beverages License and other permits issued by this Board to you under the provisions of the Alcoholic Beverages Article, as amended, should not be suspended or revoked as required by this Board by Section 4-604 of said Article, following your conviction and/or violation of said law, to wit:

Location of Incident: t/a New Food Way, 1501 Broening Highway, 21224 ("the establishment").

Violation of Rule 4.01(a) – Sales to Minors – December 22, 2022 – On December 22, 2022, Board of Liquor License Commissioners ("BLLC") Inspector Tudhope, Inspector Jordan, Agent Perez, and Chief Inspector Chrissomallis, along with a member of the Baltimore Police Department Vice Unit ("BPD Vice") conducted numerous underage investigations throughout the City. Working with the BLLC and BPD Vice in an undercover capacity were BPD Cadet Degraffinried and Cadet Baerga Rodriguez, who at the time of this investigation were both under the legal drinking age of 21 years old.

At approximately 9:15pm, Cadets Degraffinried and Baerga Rodriguez entered the establishment. At this time, the Cadets were successful in purchasing two (2) 23.5 oz. cans of Sour Grape Four Loko for \$7.40, using the \$20 bill provided to them to make purchases. Following the purchase, Cadets Degraffinried and Baerga Rodriguez exited the establishment carrying the alcoholic beverage. Members of BPD Vice and the BLLC then entered the establishment and made contact with the seller, who identified himself as Sanjaykumar Manilal Patel, verified by his Maryland driver's license. BPD Vice and BLLC members informed Mr. Patel that he had sold alcohol to underage police cadets. The alcoholic beverages and change were returned to the establishment and the departmental \$20 bill was recovered. BPD Vice Unit and BLLC members informed Mr. Patel that he would not be criminally charged; however, a violation report would be written up for the establishment. Both agencies departed the establishment with no further incident.

If you fail to appear at the above location at the date and time as instructed by the agency, the Board will proceed with the hearing and will take such action regarding the suspension or revocation of your license and permits as warranted by evidence. If you have any questions concerning the specific rules or code cited, please refer to Rules and Regulations for the Board of Liquor License Commissioners for Baltimore City or the Alcoholic Beverages Article of the Annotated Code of Maryland for reference purposes. If you have any questions or concerns regarding this matter please contact Deputy Executive Secretary, Nicholas T.R. Blendy, at 410-396-4377.

**BY ORDER OF THE BOARD OF LIQUOR LICENSE
COMMISSIONERS FOR BALTIMORE CITY**

Albert Matricciani, Jr., Chairman

**BOARD OF LIQUOR LICENSE
COMMISSIONERS
FOR BALTIMORE CITY**

Board of Liquor License Commissioners

For Baltimore City
1 North Charles Street, 15th Floor
Baltimore, Maryland, 21201

VIOLATION REPORT

Location Address:	1501 BROENING HIGHWAY 21224		
Licensee Information (Trade Name):	NEW FOOD WAY		
Corporation Name	MESVA, INC.		
License Type:	Class " A" Beer and Wine		
Contact:			
Bouncer/Security Name (if applicable):		D.O.B.	
Date Violation Issued:	12/22/2022	9:15:00 PM	

Violation Reporting Facts:

On December 22, 2022 I, Inspector Tudhope, Inspector Jordan, Agent Perez and Chief Inspector Chrissomallis from the BLLC along with a member of BPD Vice conducted numerous underage investigations throughout the city. Working with our two agencies in an undercover capacity were Cadets Degraffinried and Cadet Baerga Rodriguez, who at the time of this investigation were under the legal drinking age of 21.

At approximately 9.15Pm, Cadets Degraffinried and Baerga Rodriguez entered the establishment known as New Food Way located at 1501 Broening Highway. At this time, the Cadets were successful in purchasing two 23.5 oz cans of Sour Grape Four Loko for \$7.40 utilizing the \$20 bill provided to them.

Following the purchase, Cadets Degraffinried and Baerga Rodriguez exited the establishment carrying the alcoholic beverage. Members of the BPD Vice Unit and BLLC entered the establishment and made contact with the seller who identified himself as Sanjaykumar Manilal Patel verified by his Maryland driver's license. BPD Vice Unit and BLLC members informed Mr. Patel that he had sold alcohol to underage police Cadets. The alcoholic beverages and change were returned to the establishment and the departmental \$20 bill was recovered

BPD Vice Unit and BLLC members informed Mr. Patel that he would not be criminally charged however a violation report would be written up for the establishment. Both agencies departed the establishment without further incident.

Photos Taken:



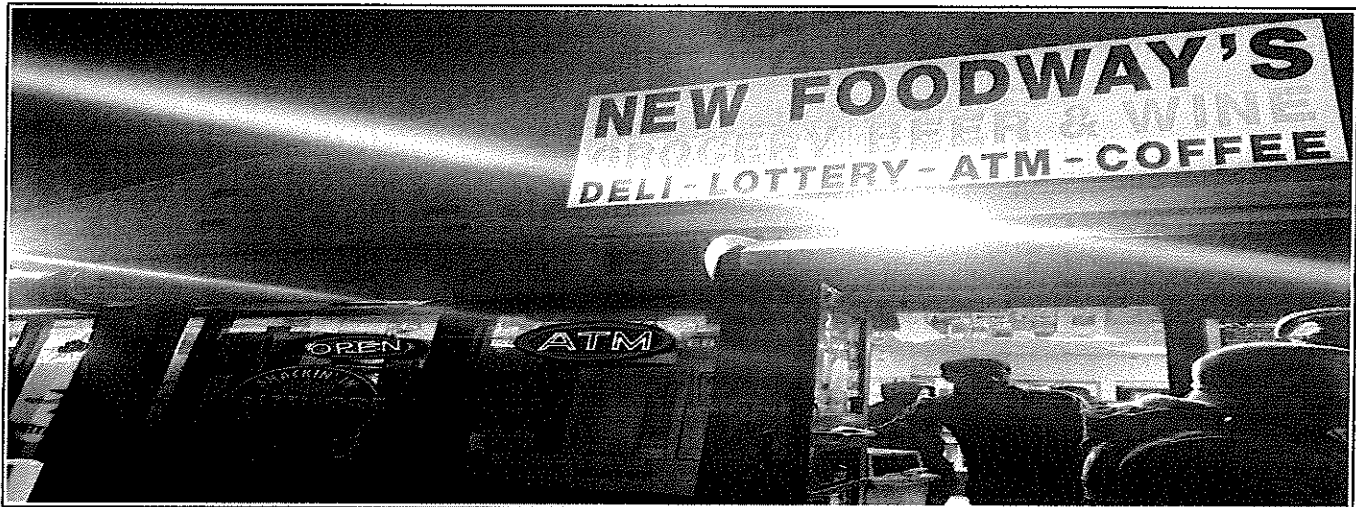

Attach Additional Photos

Report Prepared By:

Inspector(s)

Submission Date

i:\0#\w\baltimore\cindy-leigh.tudhope

12/28/2022

Approve

Disapprove



Liquor Board System

Version 1.0

Annual-Renewal ▾ | License-Transfer ▾ | One-Day ▾ | Add New License ▾ | Query ▾

License Detail

Close the License

Print License

Print Renewal Letter

<< Go Back

License Info

License Num: **WA 010**

Cert Num: **0472**

Fee: **\$110.00**

Status: **Renewed**

License Date: 5/1/2022

License Year: 2022

CR Number: 15862170

Payment Date: 04-13-22

2021 - 2022 TPP Paid

2022 Trader's License

Update Info

Click to Start License Renewal

Add Adult Entertainment License

Add New Adult Entertainment License

Location

Corp Name: **MESVA, INC.**

Trade Name: **NEW FOOD WAY**

Zone Code: 12

Phone: 410-631-7177

Block Num: 1501

City: BALTIMORE

Street: BROENING HIGHWAY

State: MD

Zip: 21224

CR Number: 15862170

Portion of Business Used:

CONTINUE TO USE AS A CONVENIENCE STORE-LIQUOR LICENSE TRANSFER

Restriction:

Edit the License Location Info

Alternate Mailing Address

License Owners

First Name	Last Name	Street	City	State	Zip	Action	Change Owner
BHAVESHKUMAR	PATEL	1720 VICTORY BOULEVARD	STATEN ISLAND	NY	10314	Edit	Remove Owner

Sunday License

License Num: **WA 010** Cert Num: **0472** Fee: **\$110.00**
 License **11/27/2022; 12/4/2022; 12/11/2022; 12/18/2022; 12/25/2022;**
 Dates:

Comments

Date	Comment	Action
01/11/2023	Alcohol Awareness expires on 01/07/2027; SANJAYKUMAR PATEL and MUKESHKUMAR PATEL (certified by John S. Murray)..../sb	Delete
10/31/2022	Holiday Special Sundays: 11/27/22, 12/04/22, 12/11/22, 12/18/22, & 12/25/22; Invoice #127414..../sb	Delete
10/13/2021	Holiday Special Sundays: 11/28/21, 12/05/21, 12/12/21, 12/19/21, & 12/26/21; Invoice #123126...../sb	Delete
10/20/2020	Holiday Special Sundays: 11/29/20, 12/06/20, 12/13/20, 12/20/20, & 12/27/20; Invoice #120101...../SB	Delete
09/11/2019	Alcohol Awareness expires on 09/08/23 Bhaveshkumar Patel (certified by John S Murray)..../sb	Delete
09/06/2019	Holiday Special Sundays: 12/01/19, 12/08/19, 12/15/19, 12/22/19 & 12/29/19; Invoice #117866 = \$375.00..../sb	Delete
07/10/2019	Submitted 2018 & 2019 Trader's License.... /sb	Delete
02/05/2019	Alcohol Awareness expires on January 28, 2023 (John Murray); Sanjaykumar Patel..../sb	Delete
09/13/2018	Holiday Special Sundays: 11/25/18, 12/02/18, 12/09/18, 12/16/18, 12/23/18 and 12/30/18; invoice #113315 = \$450.00.... /sb	Delete
10/11/2016	Holiday Special Sundays: 11/27/16, 12/04/16, 12/11/16, 12/18/16 & 12/25/16, Invoice #104231 = \$375.00.... /sb	Delete
09/16/2015	Alcohol Awareness expires 09/05/19 (Bhaveshkumar Patel).	Delete
05/07/2015	3/26/15 Application to tranfer ownership APPROVED 3-0 vote	Delete
05/06/2015	Alcohol Awareness expies 2/28/2019 (Sanjaykumar Patel)	Delete
04/07/2015	3/5/15 Public Hearing re: Application to transfer ownership. Rescheduled licensee out of town	Delete
03/26/2015	PAID \$100.00 FEE FROM HEARING ON 03/26/15.../sb	Delete
03/17/2015	Received clearance tax hold on 2/20/2015	Delete
03/09/2009	3/6/08 Public hearing re: application to transfer ownership and location of Class "D" Beer & Wine license presently in the name of Carlos O Charlies at 3509-10 Eastern Avenue to the applicants at the new location 1501 Broening Highway and change to a Class "A" Beer & Wine license	Delete

[Print History \(Print Card\)](#)

License num: WA 010 Address: 1501 BROENING HIGHWAY
 Trade Name: NEW FOOD WAY

Comment:

[Add Comment](#)

Hold Info

Powered by:

MESVA, INC.: D16264913

Department ID Number:

D16264913

Business Name:

MESVA, INC.

Principal Office: ⓘ

1501 BROENING HIGHWAY
BALTIMORE MD 21224

Resident Agent: ⓘ

BHAVESHKUMAR C. PATEL
1501 BROENING HIGHWAY
BALTIMORE MD 21224

Status:

INCORPORATED

Good Standing:

THIS BUSINESS IS IN GOOD STANDING

Business Type:

CORPORATION

Business Code:

03 ORDINARY BUSINESS - STOCK

Date of Formation/ Registration:

01/07/2015

State of Formation:

MD

Stock Status:

STOCK

Close Status:

YES

February 9, 2023

Licensee(s): Brain Lawrence
The Avenue K&B, LLC., T/a The Avenue Kitchen and Bar
911 W. 36th Street 21211

Class: "B" Beer, Wine & Liquor License

Violation of Rule 4.17 – Storage – November 25, 2022 – On November 25, 2022, Board of Liquor License Commissioners ("BLLC") Agent Darryl Clark arrived at the establishment to find a table set up with coffee and tea and bottles of liquor that were displayed on the sidewalk in front of the establishment, outside of the premises. The Agent met with General Manager Ali Sahin and explained to him and staff that they cannot do that unless they have an extension of the premises for the use of alcohol. Upon inspection, the manager could not produce a valid Trader's License. Agent Clark issued a violation for the storage of the alcohol outside the premises and gave them 7-10 business days to obtain a valid 2022 Trader's License. Manager removed the table with the departure of the Agent. Agent left the establishment without further incident.

(a) **Service on Licensee(s):** Summons issued to the licensee(s) on 1/26/2023.

(b) **Witnesses Summoned:** Summons issued to Agent Clark on 1/26/2023.

(c) **Violation History of Current Licensee:** The current corporation has no history of violations.

(d) **License Transfer Date:** The license transferred to the above named entity in 2018.

Board's Decision:

State of Maryland

Board of Liquor License Commissioners

for Baltimore City
1 N. Charles Street, Suite 1500
Baltimore, Maryland, 21201-3724
Phone: (410) 396-4377

NOTICE

To: The Avenue K&B LLC
t/a The Avenue Kitchen and Bar
911 36th Street West 21211

Date: January 26, 2023

**Licensee may be represented by
Counsel before board**

You are hereby notified to appear before the Board of Liquor License Commissioners for Baltimore City at 10:30 o'clock AM on the 9th day of February 2023, at **City Hall, 100 North Holliday Street, Room 215, Baltimore, MD 21202**, to show cause why your Alcoholic Beverages License and other permits issued by this Board to you under the provisions of the Alcoholic Beverages Article, as amended, should not be suspended or revoked as required by this Board by Section 4-604 of said Article, following your conviction and/or violation of said law, to wit:

Location of Incident: t/a The Avenue Kitchen and Bar, 911 36th Street West 21211 ("the establishment").

Violation of Rule 4.17 – Storage – November 25, 2022 – On November 25, 2022, Board of Liquor License Commissioners ("BLLC") Agent Darryl Clark arrived at the establishment to find a table set up with coffee and tea and bottles of liquor that were displayed on the sidewalk in front of the establishment, outside of the premises. The Agent met with General Manager Ali Sahin and explained to him and staff that they cannot do that unless they have an extension of the premises for the use of alcohol. Upon inspection, the manager could not produced a valid Trader's License. Agent Clark issued a violation for the storage of the alcohol outside the premises and gave them 7-10 business days to obtain a valid 2022 Trader's License. Manager removed the table with the departure of the Agent. Agent left the establishment without further incident.

If you fail to appear at the above location at the date and time as instructed by the agency, the Board will proceed with the hearing and will take such action regarding the suspension or revocation of your license and permits as warranted by evidence. If you have any questions concerning the specific rules or code cited, please refer to Rules and Regulations for the Board of Liquor License Commissioners for Baltimore City or the Alcoholic Beverages Article of the Annotated Code of Maryland for reference purposes. If you have any questions or concerns regarding this matter please contact Deputy Executive Secretary, Nicholas T.R. Blendy, at 410-396-4377.

**BY ORDER OF THE BOARD OF LIQUOR LICENSE
COMMISSIONERS FOR BALTIMORE CITY**

Albert Matricciani, Jr., Chairman

**BOARD OF LIQUOR LICENSE
COMMISSIONERS
FOR BALTIMORE CITY**

Board of Liquor License Commissioners

For Baltimore City
1 North Charles Street, 15th Floor
Baltimore, Maryland, 21201

VIOLATION REPORT

<i>Location Address:</i>	911 36TH STREET WEST 21211
<i>Licensee Information (Trade Name):</i>	THE AVENUE KITCHEN AND BAR
<i>Corporation Name</i>	THE AVENUE K&B LLC
<i>License Type:</i>	Class "B" Beer, Wine and Liquor
<i>Contact:</i>	
<i>Bouncer/Security Name (if applicable):</i>	<input type="text"/> D.O.B. <input type="text"/>
<i>Date Violation Issued:</i>	<input type="text"/> <input type="text"/>

Violation Reporting Facts:

On 11/25/2022 @ 4:00 PM Agent Darryl Clark arrived to the establishment known as The Avenue Kitchen & Bar 911 W 36th Street to find a table was set up with coffee and tea and bottles of liquor that were on displayed on the side walk of the establishment. The Agent meet with General Manager Ali Sahin and explained to him and staff that they cannot do that unless they have an extension for the use of alcohol. Upon inspection the manager could not provide a 22 Traders license. Agent issued a violation & 7-10 business days to obtain a 22 Traders license. Manager removed the table with liquor before the departure of the Agent. Agent left establishment without further incident, end of report.

Photos Taken:



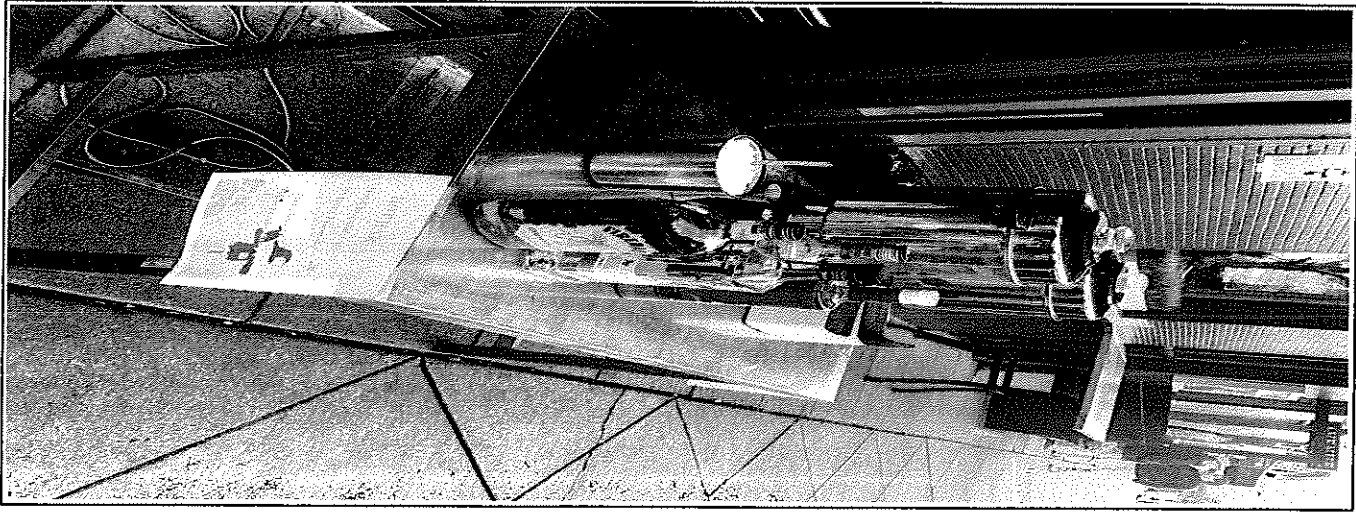

Attach Additional Photos

Report Prepared By:

Inspector(s)

Submission Date

i:\0#.w\|baltimore\darryl.clark

11/30/2022

 Approve

Disapprove

BOARD OF LIQUOR LICENSE COMMISSIONERS OF BALTIMORE CITY
INSPECTOR'S REPORT: Routine **Compliance**
 Complaint **Adult Entertainment** **Special Investigation**

ORATE NAME/LICENSEE(S): _____
 SS: _____ DATE AND TIME: _____
 CT: _____ CLASS: _____ INSPECTOR: _____
 OF PERSON IN CONTROL: _____

External Appearance	Kitchen
an and Free of Debris	Inspector Comments:
Internal Appearance	
ation of Bar	
pe of Bar	
dition of Bar Area/Floors	
Water	
nfecant Solution	
se Compartment Sink	Restroom
Package Goods/BD7 Checklist	Inspector Comments:
etproof Partitioning	
arate Pkg Goods Dept.	
arate Pkg Goods Store	
Tavern Open and Operating	
ng Household/Grocery	
Dining Area	
acity	
tion of Dining Area	Public Safety
dition of Dining Area/Floors	Exits Marked, Unobstructed
tation	Fire Capacity:
u	Adult Entertainment - If Applicable
Business Records	License is Valid
er's License	Dancers Present 18 and older
hol Awareness Certification Date	Cleanliness of Dressing Room
ad:	Ancillary Services
oyee Records	Live Entertainment (Describe):
hol Beverage Information Invoice bers and Date:	
Invoices (If Applicable)	Outdoor Table Service

VIOLATIONS NOTED

INSTRUCTIONS GIVEN TO LICENSEE

SIGNATURE OF LICENSEE OR MANAGER

INSPECTOR'S COMMENTS

White Copy = Licensee Yellow Copy = BLLC Inspector Signature
 1210-25-11

Code: Satisfactory = Unsatisfactory = Not Applicable = N/A



Liquor Board System

Version 1.0

Annual-Renewal ▾ | License-Transfer ▾ | One-Day ▾ | Add New License ▾ | Query ▾

License Detail

[Close the License](#)

[Print License](#)

[Print Renewal Letter](#)

[<< Go Back](#)

License Info

License Num: **LB 240**

Cert Num: **0954**

Fee: **\$2,520.00** Status: **Renewed**

License Date: 5/1/2022

License Year: 2022

CR Number: 16864650

Payment Date: 05-16-22

2021 - 2022 TPP Paid

2022 Trader's License

[Update Info](#)

[Click to Start License Renewal](#)

Add Adult Entertainment License

[Add New Adult Entertainment License](#)

Location

Corp Name: **THE AVENUE K&B LLC**

Trade Name: **THE AVENUE KITCHEN AND BAR**

Zone Code: 38

Phone: 443-961-8515

Block Num: 911

City: BALTIMORE

Street: 36TH STREET WEST

State: MD

Zip: 21211

CR Number: 16864650

Portion of Business Used:

THE PREMISES IS USE AS A RESTAURANT WITH CATERING AND OUTDOOR TABLE SERVICES FOR 8 TABLES AND 32 SEAT WITH LIVE ENTERTAINEMNT

Restriction:

[Edit the License Location Info](#)

[Alternate Mailing Address](#)

License Owners

First Name	Last Name	Street	City	State	Zip	Action	Change Owner
BRIAN	LAWRENCE	3759 KESWICK RD	Baltimore	MD	21211	Edit	Remove Owner

Comments

Date	Comment	Action
06/08/2022	*****RELEASED STATE OF MD TAX HOLD.***** /mb	Delete
06/08/2022	02-04-2022 Replacement of Bad check \$2,520.00 for Invoice #122931 was paid on Feb. 4, 2022 on Inv. # 123778 \$2,520.00 and Bad Check Fee \$30.00, Inv. # 123779.../mb	Delete
02/01/2022	*****STATE OF MD TAX HOLD, letter sent to the Business address on January 27, 2022.*****/mb	Delete
01/20/2022	The License fee \$2,520 paid on August 24, 201 Inv. 122931 was returned back. The reason for return was no check account #. I called to the business and informed Ms. Libby to pay the License fee \$2,520.00 and bad check fee \$30.00 in a separate money order or cashier check...mb	Delete
07/06/2021	Processed 2021 renewal application; Invoice #122558 2020 renewal application was not submitted...k/r	Delete
01/19/2021	*****RELEASED STATE OF MD TAX HOLD.***** /mb	Delete
07/22/2020	Issued outdoor license extension starting July 22, 202 until the governor has lifted his executive order; DOT permit # ROW2020-SE1025950...k/r	Delete
01/28/2020	*****STATE OF MD TAX HOLD, letter sent to the Business address on January 28, 2020.*****/mb	Delete
10/29/2019	Received Certificate on Good Standing so it is cleared for Personal Property hold on October 29, 2019..../mb.	Delete
09/26/2019	***PERSONAL PROPERTY TAX OWED TO CITY OF BALTIMORE Letter sent to Licensee/s Home Address on September 26, 2019.*** /mb	Delete
06/25/2019	Submitted 2018 Trader's License.... /sb	Delete
09/25/2018	Cease and desist letter sent to the Tiny Wine Shop located at 711 West 40th Street for unlawful sales of alcoholic beverages. As per inspection and news article, owner of "The Avenue" located at 911 West 36th Street was responsible for the creation and operation of this establishment. Letters sent to establishment and licensee. Copies in file. TRA.	Delete
02/13/2018	02/13/18-Resend App to home addresses.... /sb	Delete
02/13/2018	02/12/18 - Returned To Sender; Attempted; Not Known; Unable To Forward.... /sb	Delete
01/25/2018	*****STATE OF MD TAX HOLD, letter sent to Licensee on January 23, 2018.***** /sb	Delete
12/28/2017	12/07/17 - Public Hearing RE: Application to Transfer Ownership, requesting Live Entertainment and Outdoor Table Service - APPROVED (3-0 VOTE).... /sb	Delete
09/13/2017	Management Agreement received by Agency today allowing operation of "The Avenue" concept while transfer is pending. Copy placed in file. TRA.	Delete
09/08/2017	Application for transfer of ownership, requesting live entertainment and outdoor table service filed on behalf of The Avenue K&B, LLC T/a The Avenue, Brian Lawrence on 8/18/17 /kk	Delete
03/21/2017	Last license renewal, the licensees submitted to remove Ms. Jennifer Whalen. This was overlooked with the renewal process; moving forward with the 2017-2018 License renewal, she will be removed from the license. See 2016-2017 license renewal application for documentation from Pete Prevas regarding this subject. /kk	Delete

Print History (Print Card)

License num: LB 240 Address: 911 36TH STREET WEST
Trade Name: THE AVENUE KITCHEN AND BAR

Comment:

Add Comment

Hold Info

Powered by:

THE AVENUE K&B LLC: W18071423

Department ID Number:

W18071423

Business Name:

THE AVENUE K&B LLC

Principal Office: ⓘ

911 W. 36TH STREET
BALTIMORE MD 21218

Resident Agent: ⓘ

JOHN PATRICK DAHLGREN
911 WEST 36TH STREET
BALTIMORE MD 21211

Status:

ACTIVE

Good Standing:

THIS BUSINESS IS NOT IN GOOD STANDING

Reason(s) Entity is NOT in Good Standing:

Annual Report Due For 2022

Business Type:

DOMESTIC LLC

Business Code:

20 ENTITIES OTHER THAN CORPORATIONS

Date of Formation/ Registration:

06/14/2017

State of Formation:

MD

Stock Status:

N/A

Close Status:

N/A

February 9, 2023

Licensee(s): Gurpreet Kaur
Sole Proprietorship., T/a Tavern Bar
2148 Wilkens Avenue 21223

Class: "D" Beer, Wine & Liquor License

Violation of Alc. Bev. Art. 12-2005(d) – December 16, 2022 – On December 16, 2022, Board of Liquor License Commissioners ("BLLC") Inspector Cindy Tudhope and Inspector Rosalba Jordan along with a member of the Baltimore Police Department Vice Unit ("BPD Vice") conducted an investigation at the establishment for being open after the allowable operating hours of 10:00pm. BLLC Inspectors and BPD Vice arrived outside the establishment at approximately 9:50pm and proceeded to observe the establishment until approximately 10:15pm. BLLC Inspectors observed people entering and exiting the establishment after 10:00pm and that the lights were on and the front door was open. At approximately 10:15pm, BLLC Inspectors and BPD Vice entered the establishment through the open door, and once inside, they observed approximately 10-15 people sitting and standing inside the establishment drinking. Inspector Tudhope made contact with a Mr. Nigel Procter who stated he was the new owner of the establishment and that they were in the middle of a transfer of ownership. Inspector Tudhope informed Mr. Procter that he was open and operating past the allowable hours of operation of 10:00pm. Inspector Tudhope asked to see the establishment's liquor license and verified that the establishment was not to be operating after 10:00pm, as was stated on the license. Inspector Tudhope further observed right below where the letter was displayed a letter sent out by the BLLC dated June 29, 2021 addressed to Tavern Bar stating the new hours of operation displayed and hanging in full view of the other permits. Mr. Procter stated that they closed at 10:00pm, but that people were just finishing their drinks and that nobody was being served past 10:00pm. At this time, he and his staff asked people to "take it to the head" and people proceeded to drink fast while walking out. Inspectors heard one patron state that he wanted his money back as he had just arrived five (5) minutes ago and paid for his drink and did not appreciate that he was not able to finish his beer and that the beer was still full. Inspector Tudhope issued a violation and BLLC Inspectors and BPD Vice left the establishment without further incident.

Violation of Rule 4.05 – Prohibited Hours – December 16, 2022 – On December 16, 2022, Board of Liquor License Commissioners ("BLLC") Inspector Cindy Tudhope and Inspector Rosalba Jordan along with a member of the Baltimore Police Department Vice Unit ("BPD Vice") conducted an investigation at the establishment for being open after the allowable operating hours of 10:00pm. BLLC Inspectors and BPD Vice arrived outside the establishment at approximately 9:50pm and proceeded to observe the establishment until approximately 10:15pm. BLLC Inspectors observed people entering and exiting the establishment after 10:00pm and that the lights were on and the front door was open. At approximately 10:15pm, BLLC Inspectors and BPD Vice entered the establishment through the open door, and once inside, they observed approximately 10-15 people sitting and standing inside the establishment drinking. Inspector Tudhope made contact with a Mr. Nigel Procter who stated he was the new owner of the establishment and that they were in the middle of a transfer of ownership. Inspector Tudhope informed Mr. Procter that he was open and operating past the allowable hours of operation of 10:00pm. Inspector Tudhope asked to see the establishment's liquor license and verified that the establishment was not to be operating after 10:00pm, as was stated on the license. Inspector Tudhope further observed right below where the letter was displayed a letter sent out by the BLLC dated June 29, 2021 addressed to Tavern Bar stating the new hours of operation displayed and hanging in full view of the other permits. Mr. Procter stated that they closed at 10:00pm, but that people were just finishing their drinks and that nobody was being served past 10:00pm. At this time, he and his staff asked people to "take it to the head" and people proceeded to drink fast while walking out. Inspectors heard one patron state that he wanted his money back as he had just arrived five (5) minutes ago and paid for his drink and did not appreciate that he was not able to finish his beer and that the beer was still full. Inspector Tudhope issued a violation and BLLC Inspectors and BPD Vice left the establishment without further incident.

(a) **Service on Licensee(s):** Summons issued to the licensee(s) on 1/26/2023.

(b) **Witnesses Summoned:** Summons issued to Inspector Tudhope and Inspector Jordan on 1/26/2023.

(c) **Violation History of Current Corporation:** Licensee(s) appeared before the Board 5/23/2019 in reference to:

- Violation of Rule 4.01(a) - Sales to Minors
- \$350 + \$125 admin fee
- \$475 total fine

(d) **License Transfer Date:** The license transferred to the above named corporation on 5/1/2017.

Board's Decision:

State of Maryland

Board of Liquor License Commissioners

for Baltimore City
1 N. Charles Street, Suite 1500
Baltimore, Maryland, 21201-3724
Phone: (410) 396-4377

NOTICE

To: Gurpreet Kaur (sole proprietor)
t/a Tavern Bar
2148 Wilkens Avenue 21223

Date: January 26, 2023

**Licensee may be represented by
Counsel before board**

You are hereby notified to appear before the Board of Liquor License Commissioners for Baltimore City at 10:30 o'clock AM on the 9th day of February 2023, at **City Hall, 100 North Holliday Street, Room 215, Baltimore, MD 21202**, to show cause why your Alcoholic Beverages License and other permits issued by this Board to you under the provisions of the Alcoholic Beverages Article, as amended, should not be suspended or revoked as required by this Board by Section 4-604 of said Article, following your conviction and/or violation of said law, to wit:

Location of Incident: t/a Tavern Bar, 2148 Wilkens Avenue 21223 (“the establishment”).

Violation of Alc. Bev. Art. 12-2005(d) – December 16, 2022 – On December 16, 2022, Board of Liquor License Commissioners (“BLLC”) Inspector Cindy Tudhope and Inspector Rosalba Jordan along with a member of the Baltimore Police Department Vice Unit (“BPD Vice”) conducted an investigation at the establishment for being open after the allowable operating hours of 10:00pm. BLLC Inspectors and BPD Vice arrived outside the establishment at approximately 9:50pm and proceeded to observe the establishment until approximately 10:15pm. BLLC Inspectors observed people entering and exiting the establishment after 10:00pm and that the lights were on and the front door was open. At approximately 10:15pm, BLLC Inspectors and BPD Vice entered the establishment through the open door, and once inside, they observed approximately 10-15 people sitting and standing inside the establishment drinking. Inspector Tudhope made contact with a Mr. Nigel Procter who stated he was the new owner of the establishment and that they were in the middle of a transfer of ownership. Inspector Tudhope informed Mr. Procter that he was open and operating past the allowable hours of operation of 10:00pm. Inspector Tudhope asked to see the establishment’s liquor license and verified that the establishment was not to be operating after 10:00pm, as was stated on the license. Inspector Tudhope further observed right below where the letter was displayed a letter sent out by the BLLC dated June 29, 2021 addressed to Tavern Bar stating the new hours of operation displayed and hanging in full view of the other permits. Mr. Procter stated that they closed at 10:00pm, but that people were just finishing their drinks and that nobody was being served past 10:00pm. At this time, he and his staff asked people to “take it to the head” and people proceeded to drink fast while walking out. Inspectors heard one patron state that he wanted his money back as he had just arrived five (5) minutes ago and paid for his drink and did not appreciate that he was not able to finish his beer and that the beer was still full. Inspector Tudhope issued a violation and BLLC Inspectors and BPD Vice left the establishment without further incident.

Violation of Rule 4.05 – Prohibited Hours – December 16, 2022 – On December 16, 2022, Board of Liquor License Commissioners (“BLLC”) Inspector Cindy Tudhope and Inspector Rosalba Jordan along with a member of the Baltimore Police Department Vice Unit (“BPD Vice”) conducted an investigation at the establishment for being open after the allowable operating hours of 10:00pm. BLLC Inspectors and BPD Vice arrived outside the establishment at approximately 9:50pm and proceeded to observe the establishment until approximately 10:15pm. BLLC Inspectors observed people entering and exiting the establishment after 10:00pm and that the lights were on and the front door was open. At approximately 10:15pm, BLLC Inspectors and BPD Vice entered the establishment through the open door, and once inside, they observed approximately 10-15 people sitting and standing inside the establishment drinking. Inspector Tudhope made contact with a Mr. Nigel Procter who stated he was the new owner of the establishment and that they were in the middle of a transfer of ownership. Inspector Tudhope informed Mr. Procter that he was open and operating past the allowable hours of operation of 10:00pm. Inspector Tudhope asked to see the establishment’s liquor license and verified that the establishment was not to be operating after 10:00pm, as was

stated on the license. Inspector Tudhope further observed right below where the letter was displayed a letter sent out by the BLLC dated June 29, 2021 addressed to Tavern Bar stating the new hours of operation displayed and hanging in full view of the other permits. Mr. Proctor stated that they closed at 10:00pm, but that people were just finishing their drinks and that nobody was being served past 10:00pm. At this time, he and his staff asked people to "take it to the head" and people proceeded to drink fast while walking out. Inspectors heard one patron state that he wanted his money back as he had just arrived five (5) minutes ago and paid for his drink and did not appreciate that he was not able to finish his beer and that the beer was still full. Inspector Tudhope issued a violation and BLLC Inspectors and BPD Vice left the establishment without further incident.

If you fail to appear at the above location at the date and time as instructed by the agency, the Board will proceed with the hearing and will take such action regarding the suspension or revocation of your license and permits as warranted by evidence. If you have any questions concerning the specific rules or code cited, please refer to Rules and Regulations for the Board of Liquor License Commissioners for Baltimore City or the Alcoholic Beverages Article of the Annotated Code of Maryland for reference purposes. If you have any questions or concerns regarding this matter please contact Deputy Executive Secretary, Nicholas T.R. Blendy, at 410-396-4377.

**BY ORDER OF THE BOARD OF LIQUOR LICENSE
COMMISSIONERS FOR BALTIMORE CITY**

Albert Matricciani, Jr., Chairman

**BOARD OF LIQUOR LICENSE
COMMISSIONERS
FOR BALTIMORE CITY**

Board of Liquor License Commissioners

For Baltimore City
1 North Charles Street, 15th Floor
Baltimore, Maryland, 21201

VIOLATION REPORT

Location Address:	2148 WILKENS AVENUE 21223		
Licensee Information (Trade Name):	TAVERN BAR		
Corporation Name	N/A		
License Type:	Class "D" Beer, Wine and Liquor		
Contact:			
Bouncer/Security Name (if applicable):		D.O.B.	
Date Violation Issued:			

Violation Reporting Facts:

On December 16, 2022. I, Inspector Cindy Tudhope and Rosalba Jordan from the Board of Liquor License Commissioners (BLLC) along with a member of the Baltimore Police Department Vice Unit (BPD Vice) did an investigation at 2148 Wilkens avenue at the establishment known as Tavern Bar for being open operating after 10PM. I, Inspector Tudhope, Jordan and a member of Vice arrived at approx. 9:50PM and proceeded to observe establishment from our car till approx. 10:15PM, I observed people entering and exiting establishment after 10PM and lights on inside and front door open. At approximately 10:16PM we entered the establishment through the open door and once inside the bar, we observed approximately 10-15 people sitting and standing inside establishment drinking. I Inspector Tudhope made contact with a Mr. Nigel Proctor who stated he was the new owner of establishment and they were in the middle of a transfer of ownership. I Inspector Tudhope informed Mr. Proctor that he was open and operating past he allowed hours of operation of 10PM. I asked to see the establishments liquor license and verified that the establishment was not to operating after 10PM as stated on it, I, also observed right below where the Liquor license was displayed a letter sent out by the BLLC dated June 29th, 2021 addressed to Tavern Bar stating the new hours of operation displayed and hanging in full view with all the other permits. Mr. Proctor stated they closed at 10PM but people where just finishing their drinks and nobody was being served past 10PM, at this time he and his staff asked people to "take it to the Head" and people proceeded to drink fast while walking out, Inspector heard one patron state that he wanted his money back as he had just arrived 5 Min ago and paid for his drink and did not appreciate that he was not able to finish his beer and the beer was still full. I, Inspector issued a violation and Inspectors and Vice left the establishment without further incident

Photos Taken:



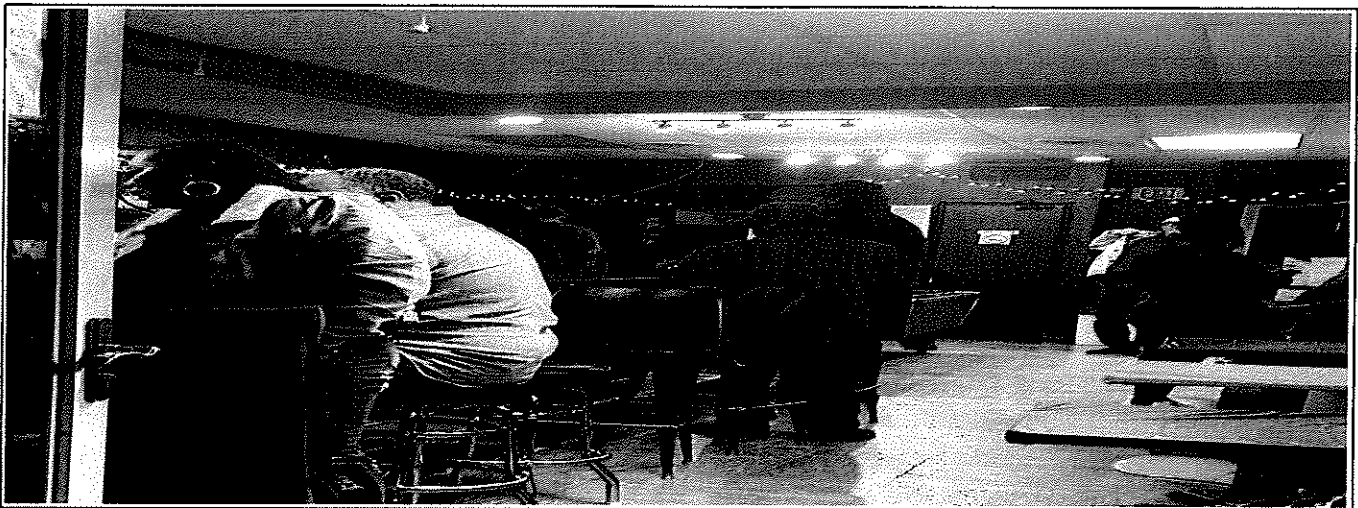
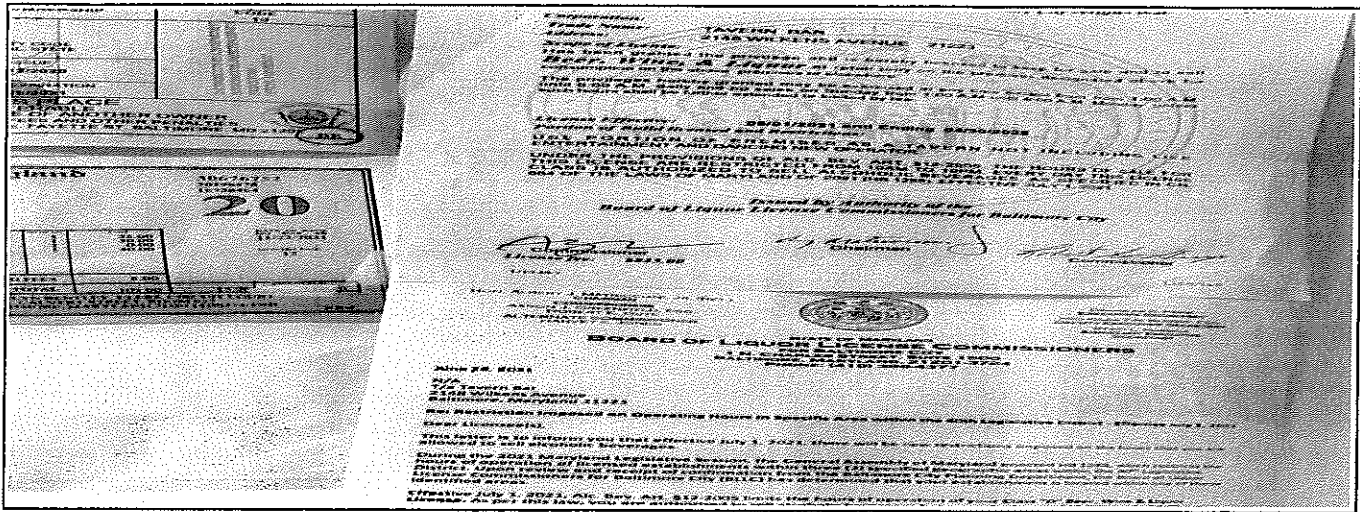

Attach Additional Photos

Report Prepared By:

Inspector(s)

Submission Date

i:0#w|baltimore\cindy-leigh.tudhope

12/21/2022

~~Approve~~

Disapprove



Liquor Board System

Version 1.0

Annual-Renewal ▾ | License-Transfer ▾ | One-Day ▾ | Add New License ▾ | Query ▾

License Detail

Close the License

Print License

Print Renewal Letter

<< Go Back

License Info

License Num: **LD 044**

Cert Num: **0916**

Fee: **\$825.00**

Status: **Renewed**

License Date: 5/1/2022

License Year: 2022

CR Number: 16728464

Payment Date: 05-19-22

2021 - 2022 TPP Paid

2022 Trader's License

Update Info

Click to Start License Renewal

Add Adult Entertainment License

Add New Adult Entertainment License

Location

Corp Name: **N/A**

Trade Name: **TAVERN BAR**

Zone Code: 32

Phone: 443-447-9555

Block Num: 2148

City: BALTIMORE

Street: WILKENS AVENUE

State: MD

Zip: 21223

CR Number: 16728464

Portion of Business Used:

USE PORTION OF PREMISES AS A TAVERN NOT INCLUDING LIVE ENTERTAINMENT AND DANCING NEW OPERATOR

Restriction:

UNDER THE PROVISIONS OF ALC. BEV. ART. §12-2005, THE HOURS OF SALE FOR THIS LICENSE ARE RESTRICTED FROM 10AM TO 10PM, EVERY DAY THIS LICENSE CLASS IS AUTHORIZED TO SELL ALCOHOLIC BEVERAGES, AS SPECIFIED IN CH. 664 OF THE LAWS OF MARYLAND OF 2021 (HB 1288), EFFECTIVE JULY 1, 2021

Edit the License Location Info

Alternate Mailing Address

License Owners

First Name	Last Name	Street	City	State	Zip	Action	Change Owner
GURPREET	KAUR	419 IMLA ST	Baltimore	MD	21224	Edit	Remove Owner

Comments

Date	Comment	Action
12/09/2022	Application for transfer of ownership requesting delivery of alcoholic beverages filed on behalf of P&M Properties Soutlions, LLC T/a Edna's Place, Kierra Latrice Proctor on 12/1/2022 /kk	Delete
10/19/2022	9/30/2022 termination for transfer pending letter was sent to all applicant(s) and lawyer(s) that filed..k/r	Delete
09/30/2022	09/12/22 - Time expired on Pending Transfer, so this file is DEAD.../sb	Delete
06/24/2022	6/23/2022 - Public Hearing Re: Request for a transfer hardship extension - GRANTED (3-0 vote) *Additional 90 days granted for transfer*...../jr	Delete
06/03/2022	****RELEASED STATE OF MD TAX HOLD CR # 01991963**** /mb	Delete
03/16/2022	3/16/2022 90 day pending warning letter was sent to all applicant(s) and attorney(s)...k/r	Delete
12/17/2021	12/16/2021 - Virtual Public Hearing Re: Application to transfer ownership requesting delivery of alcoholic beverages - APPROVED (3-0 vote)..../jr	Delete
11/08/2021	Alcohol Awareness expires on 10/30/2025 Niegi Proctor and Teletia Merefee (certified by John S. Murray)..../sb	Delete
11/05/2021	Application for transfer of ownership requesting delivery of alcoholic beverages filed on behalf of P & M Properties Solutions, LLC T/a Edna's Place, Kierra Latrice Proctor on 10/26/2021 /kk	Delete
07/26/2021	6/30/2021 - Revised License for new restriction on hours of operation of 10am-10pm per new law effective as of July 1, 2021 was given to inspectors and delivered to licensed location..../jr	Delete
01/28/2020	Letter hand delivered by inspector to licensee in reference to outreach meeting on 2/5/2020 at the BLLC /kk	Delete
10/29/2019	Personal Property Tax Owed to City of Baltimore was cleared on October 29, 2019.../mb.	Delete
09/27/2019	***PERSONAL PROPERTY TAX OWED TO CITY OF BALTIMORE Letter sent to Licensee/s Home Address on September 27, 2019.*** /mb	Delete
06/26/2019	5/23/2019 Public Hearing Re: Violation of Rule 4.01 (a) Sales to Minors GUILTY Rule 4.01 (a) - Fined \$350 \$350 + \$125 admin fee \$475 total fine 30 days to pay (3-0 vote) s.R	Delete
03/18/2019	3/14/2019 - Public Hearing Re: Violation of Rule 4.01 (a) Sales to Minors - REQUEST FOR POSTPONEMENT - The Board has GRANTED the request for postponement. This matter will be scheduled for a future hearing date...../jr	Delete
12/14/2018	Mailed letter of recognition for underage drinking compliance check on 12/12/18 /kk	Delete
04/25/2017	****RELEASED STATE OF MD TAX HOLD**** /sb	Delete
03/21/2017	MARYLAND SALES TAX HOLD (CR#13994446- TRANSFER)...K/R	Delete
03/16/2017	Alcohol Awareness expires 03/09/21 (Gurpreet Kaur)... /sb	Delete
03/10/2017	Alcohol Awareness expires 03/08/21 (Lorri Monaghan)... /sb	Delete
02/23/2017	02/23/17 - Public Hearing RE: Application to transfer ownership - APPROVED (3 -0 VOTE)	Delete
01/03/2017	Mark Folser sent out a letter on 12/28/2017 regrading required inspection during the license year....m/f	Delete
12/22/2016	Maryland Sales tax hold (CR#13994446-transfer) 12/22/2016...kr	Delete
12/06/2016	12/05/2016-Manger of establishment came in to pick up 2016-2017 alcohol beverage license. The documents: 2016 trader's license,2016-2017 clearance letter and letter of good standing were submitted.Ref: 10/27/2016 Public hearing re: request for hardship extension, and request to reopen after being closed for more than 90 days	Delete
11/03/2016	PAID \$100.00 for Hearing dated 10/27/16 for Hardship Extension; Invoice #104380... /sb	Delete
10/31/2016	10/28/16 - Sent Fax to Mel Kodenski office stating that Licensee owes \$100.00 for hearing administrative fee.... /sb	Delete
10/28/2016	10/27/2016- Public hearing re: request for hardship extension, and request to reopen after being closed for more than 90 days- APPROVED	Delete
08/29/2016	licensee's attorney brought in new check for correct amount. license renewed. Still waiting for request to reopen. ND	Delete
08/25/2016	Received 2016 renewal application, 1-\$50.00 check and 1-\$858.00 from licensee's attorney(Melvin Kodenski) on 08/23/16. Licensee must request a hearing to reopen after being closed for more than 90 days. Check for \$858.00 returned to attorney-incorrect amount. Letter sent to attorney and licensee notifying them that the licensee must request a hearing to reopen. ND	Delete
02/05/2016	PAID \$375.00 for Violation Hearing dated from April 30, 2015; Invoice #100302. Will return Liquor License to licensee.... /sb	Delete

02/05/2016	**Given Chief Inspector letter & invoice stating that licensee owes past due violation hearing fee (\$375.00) and notice for suspension of liquor license.... /sb	Delete
09/23/2015	Sent letter to licensee for the amount of \$375.00,owes from Violation Hearing dated on April 30, 2015.... /sb	Delete
07/07/2015	Hearing Date: April 30, 2015...Violation of Rule 4.10(a) Wholesaler Relations – March 23, 2015. Owes Liquor Board \$250.00 fine + \$125.00 admin fee. = Total \$375.00.... /sb	Delete
06/08/2015	06/05/15 RELEASED STATE OF MD TAX HOLD..... /sb	Delete
02/03/2015	State of MD Tax Hold, letter sent to merchant on January 23, 2015.	Delete
08/30/2010	07/29/09 \$650 PAID IN FULL #69634	Delete
06/19/2009	06/18/09 Public Hearing re: Violation of rule 4.01(a) & rule 3.03(c). DECISION: RULE 4.01(a)GUILTY \$500 AND RULE 3.03(c)GUILTY \$25 + \$125 ADM.FEE = \$650	Delete
03/01/2004	1/25/96 Public hearing re: Violation of Rule 4.10(a) i (Purchasing from other than a wholesaler) Guilty 5 day i suspension or \$500 fine 1/31/96 \$500 fine paid BT 00926	Delete

[Print History \(Print Card\)](#)

License num: LD 044
Trade Name: TAVERN BAR

Address: 2148 WILKENS AVENUE

Comment:

[Add Comment](#)

Hold Info

