

January 4, 2018

Applicant(s): Tzu Yen Yeh
Yuan Zheng Company, T/a Yuan & Zheng Liquor & Grocery
300 N. Gilmor Street 21223

Class: "A" Beer, Wine & Liquor License

Application to transfer ownership.

(a) Applicant(s) Information: (1) Tzu Yen Yeh was born in Tao Yuan, Taiwan in October of 1982. She lives in Baltimore, MD.

(b) Ownership Breakdown: (1) Tzu Yen Yeh (100%).

(c) Purchase Price of Business: The purchase price of the business was \$48,000

(d) Qualified Voters: Rodney Williams, Brian Knight, and Darlene Williams are qualified Baltimore City voters.

(e) Zoning: Applicants have applied for a USE permit, for the continued use of the property as a liquor store.

(f) Corporate Standing: Yuan Zheng Company is a MD Corporation and as of 12/21/2017 is active and in good standing.

(g) Posting Report: The location was posted on 12/4/2017, and checked on 12/13/2017. This meets the 10-day rule. There are 3 licensed liquor establishments in the 4x4 area: "A" BWL-2; and "BD7" BWL-1.

(h) Timeline: Last Inspection by BLLC was performed 12/6/2017. At that time, the establishment was open and operating.

(i) Letters of Support/Opposition: At this time the Board has no letters of support or opposition.

In considering this request, under the provisions of Alcohol Beverage Article 4-210(A) the Board must consider the following factors: 1. The public need and desire for the license; 2. The number and location of existing license holders; 3. The potential effect on existing license holders of the license for which application is made; 4. The potential commonality or uniqueness of the services and products to be offered by the business of the applicant; 5. The impact of the license for which application is made on the health, safety, and welfare of the community, including issues relating to crime, traffic conditions, parking, or convenience; and 6. Any other factor that the local licensing Board considers necessary.

Board's Decision:

OFFICE USE ONLY
 Date Filed _____
 Posting Date: _____
 Approved Yes No _____
 Withdrawn Yes No _____
 WC Information: _____
 Policy/Binder# _____

Application for Alcoholic Beverages License
Board of Liquor License Commissioners for Baltimore City

NEW/TRANSFER/EXPANSION/AMENDMENT(S) APPLICATION FEE - \$500.00
 After June 1, 2016 \$600.00 includes Hearing Fee

OFFICE USE ONLY
 Status of Zoning Verification
 Approved: Yes No
 Date Sent to Zoning: _____
 Initials: _____
 Zoning Info: _____

INDICATE TYPE OF LICENSE APPLICATION: TRANSFER NEW EXPANSION OF PREMISES AMENDMENT(S)
 EXPLANATION OF REQUEST: Transfer Request from Bao Ying Lin to Tzu Yen Yeh CLASS TYPE: A
 LICENSE AT THE LOCATION: 200 N. Gilmer IF TRANSFER, PREVIOUS LOCATION: 300 N. Gilmer
 CORPORATE/LLC/LLP/PARTNERSHIP NAME: Yuan Zheng Company TRADE NAME: Yuan & Zheng Liquor & Grocery
 BUSINESS PHONE NUMBER: 410-566-1565 BUSINESS CONTACT/MANAGER: Tzu Yen Yeh
 ATTORNEY FOR THE APPLICANT: Jay S. Yoo ADDRESS: 3440 Elliott Ctr. Dr. #202 PHONE: 410-465-3606
Elliott City, MD 21243

Part of Premises Used (Note: Floors and Areas for Storage): First Floor for Business / Basement for storage

Will Live Entertainment be provided? Yes No What Kind (Ex. DJ, Band, Etc.): _____

Will Outdoor Table Service Be Provided? Yes No

Off Premise Catering of Food and Alcohol? Yes No BLLC Catering Application Filed? Yes No

Delivery of alcohol? Yes No BLLC Delivery Application Filed? Yes No

Please note that as per Art. 28 § 10-202(a)(iv)(1) that an application for the issuance or transfer is not complete unless the applicant has obtained zoning approval from the City of Baltimore. Please attach Use and Occupancy Permit or letter from BMZA approving use.

1. Applicant A

Tzu Yen Yeh _____
 (Full name) (Telephone no.) E-mail (Required)
2400 Greenmount Ave., Balto., MD 21218 _____
 (Residence) Street City State Zip Code (period of residency in Baltimore City)
12/1982 _____
 (Month/Year of Birth) (Sex: Male or Female) (Place of Birth)
 Check: Yes No Have you been a resident and taxpayer of the City of Baltimore for 2 years preceding this application?
 Yes No Are you a registered voter in the City of Baltimore?

2. Applicant B

 (Full name) (Telephone no.) E-mail (Required)

 (Residence) Street City State Zip Code (period of residency in Baltimore City)

 (Month/Year of Birth) (Sex: Male or Female) (Place of Birth)
 Check: Yes No Have you been a resident and taxpayer of the City of Baltimore for 2 years preceding this application?
 Yes No Are you a registered voter in the City of Baltimore?

3. Applicant C

 (Full name) (Telephone no.) E-mail (Required)

 (Residence) Street City State Zip Code (period of residency in Baltimore City)

 (Month/Year of Birth) (Sex: Male or Female) (Place of Birth)
 Check: Yes No Have you been a resident and taxpayer of the City of Baltimore for 2 years preceding this application?
 Yes No Are you a registered voter in the City of Baltimore?

1. Has the applicant(s) been adjudged guilty of a felony in the State of Maryland or any other? Yes No - If yes, indicate applicant and explain.
Applicant A B C

2. Has the applicant(s) been adjudged guilty of violating the laws governing the sale of any alcoholic beverage or for gambling in any State, including Maryland? Yes No - If yes, mark applicant and provide explanation in adjacent space provided.
Applicant A B C

3. State whether the applicant(s) has ever been adjudged guilty of any offense against the laws of the State of Maryland or the United States.
 Yes No - If yes, mark applicant and explain.
Applicant A B C

4. Has the applicant(s) ever had a license for the sale of alcoholic beverages in the State of Maryland? Yes No If yes, mark applicant and explain.
Applicant A B C

5. Has the applicant(s) ever had a liquor license suspended or revoked? Yes No If yes, mark applicant and explain.
Applicant A B C

6. Does the applicant(s) have a pecuniary interest in any other alcoholic beverage business or business for which an alcoholic beverage license has been applied for, granted, and issued? Yes No If yes, mark applicant and explain.
Applicant A B C

7. Do the spouses or children of any of the applicant(s) have a financial interest in any other alcoholic beverages license or business in Baltimore City or any other jurisdiction in the State of Maryland? Yes No If yes, mark applicant and explain.
Applicant A B C

8. Are you financially interested in any other alcoholic beverages license applied, granted or issued? Yes No If yes, please explain.
Applicant A B C

9. Is the licensed premise currently open and operating? Yes No If yes, please explain.

10. Do any of the applicant(s) - personally or through an entity - have any indebtedness or other financial obligations to any manufacturer, brewer, distiller, or wholesaler at the time of making this application? Yes No If yes, please explain. If yes, please provide information as to the applicant(s) indebted - personally or through an entity - the amount of the indebtedness, and the name of the manufacturer, brewer, distiller, or wholesaler?
Applicant A B C

11. Please list the following information for the Manager of the establishment to be licensed:

Name	Address	Phone	Email

Applicants Applying as Business Entities - (Give name(s) and addresses - in Corporation list all officers (attach list if necessary) or in Limited Liability Company/Partnerships list all authorized persons.) *Please note that all licensees MUST have a pecuniary interest in the license applied for as per Article 2B Section 10-103(b) (10)*

- 1) NAME: Tzu Yen Yeh ADDRESS: 2400 Greenmount Ave TITLE: president %OF STOCK HELD RESIDENCE: 100
- 2) NAME: _____ ADDRESS: _____ TITLE: _____ %OF STOCK HELD RESIDENCE: _____
- 3) NAME: _____ ADDRESS: _____ TITLE: _____ %OF STOCK HELD RESIDENCE: _____
- 4) NAME: _____ ADDRESS: _____ TITLE: _____ %OF STOCK HELD RESIDENCE: _____

***** Attached is a list of the names and addresses of all outstanding stockholders who on the day of this application own more than 5% of the outstanding stock of the corporation and the articles of incorporation, partnership agreement or articles of organization. *****

**Extract from Law: If any affidavit or oath required under the provisions of this Act shall contain any false statements, the offender shall be deemed guilty of perjury. And upon indictment and conviction thereof, shall be subject to penalties provided by Law for that crime.*

CERTIFICATE OF APPLICANTS: At least one applicant whose signature appears below certifies that he/she has been a resident and taxpayer of Baltimore City, Maryland for at least two years preceding the filing of this application. Each of said applicants hereby certifies further that if the license applied for is granted, he/she will conform to all State and County laws and regulations relating to the sale of alcoholic beverages, as well as to the rules and regulations of the Board of License Commissioners for Baltimore City, and hereby grants permission to the State Comptroller, his duly authorized deputies, inspectors and clerks, The Board of License Commissioners for Baltimore City, its duly authorized agents and employees, and any peace officer of Baltimore City or the State of Maryland to inspect and search at any and all hours, without warrant, the premises and any and all parts thereof upon and in which said business is to be conducted.

x Tzu Yen Yeh _____ Signature of Applicant A
 _____ Signature of Applicant B
 _____ Signature of Applicant C

State of Maryland: Howard County ss
 THIS CERTIFIES, THAT ON THE 22nd OF July 2016
 before the subscriber a notary public of the State of Maryland, personally appeared

Tzu Yen Yeh
 The applicant (s) names in the foregoing application, and made oath in due form of law that the statement therein are true to the best of (his, her, their) knowledge and belief.

Jay S. Yoo
 NOTARY PUBLIC
 Howard County, Maryland
 (Witness my hand and seal Expires 04/30/2017)

Jay S. Yoo
 Notary Public

Name and Address of the owners of the premise/landlord: Bao Ying Lin Phone Number: _____

STATEMENT OF OWNER OF PREMISES REQUIRED IN CONNECTION WITH ALCOHOLIC BEVERAGES LAW OF MARYLAND

(I/WE) Bao Ying Lin HEREBY CERTIFY, That (I am, we are) the owner(s) of the property located at 300 N. Gilmer Baltimore, City with a Zip Code of 21223 which is named in the present application made to Board of Liquor License Commissioners of Baltimore City under the Alcoholic Beverage Laws of Maryland and assent to the granting of the license applied for, and hereby authorize the State Comptroller, his duly authorized deputies, inspectors and clerks, the Board of Liquor License Commissioners of Baltimore City, its duly authorized agents

and employees, and any peace officer of the City of Baltimore and State of Maryland, to inspect and search, without warrant, the premises upon which the business is to be conducted, and any and all parts of the building in which said business is to be conducted, at any and all hours.

(Witness (my, our) hand(s) and seal(s) this 22nd day of July in the year of 2016.

WITNESS: x Bao Ying Lin

STATE OF MARYLAND
THIS CERTIFIES, THAT ON 22nd day of July, 2016
Before the subscriber a notary public of the State of Maryland, personally appeared Bao Ying Lin

and acknowledge the execution of the foregoing statement to be true and voluntary act.

(Witness my hand and seal)
Notary Public, Jay S. Yoo
NOTARY PUBLIC
Howard County, Maryland
My Commission Expires 04/30/2017

The following certificates must be signed by at least 3 persons.

We, the undersigned citizens, real estate owners and registered voters in the City of Baltimore in which the business covered by the present application is to be conducted, certify that the qualifying applicant(s) is/are personally known to us and has been a resident or a taxpayer of Baltimore City and a resident of the State of Maryland for 2 years preceding this application.

Names	Address	Signature	DOB (Month/Year)	Length of time Acquainted with the Applicant(s)
Rodney William	710 Glenwood Ave	Rodney William	1-61	2 1/2 yrs
BRIAN Knight	2023 N. Washington St	Brian Knight	12-58	7 years
Darlene Williams	710 Glenwood Ave	Darlene Williams	07-76 / 06-60	2 years

Board of Liquor License Commissioners for the City of Baltimore,
231 East Baltimore Street, 6th Floor, Baltimore, Maryland 21202
Phone: 410-396-4377 Fax: 410-396-4382

Please note that this is a public document and upon request will be provided to the general members of the public.

Stamp Application Here
BOARD OF LIQUOR LICENSE COMMISSIONERS
2016 AUG 24 PH 3:11

RECEIVED - 8/24/16

Please present/draw a Floor Plan/Rendering of the Licensed Premises here. If you have a professionally drafted rendering, please attach it to the application.

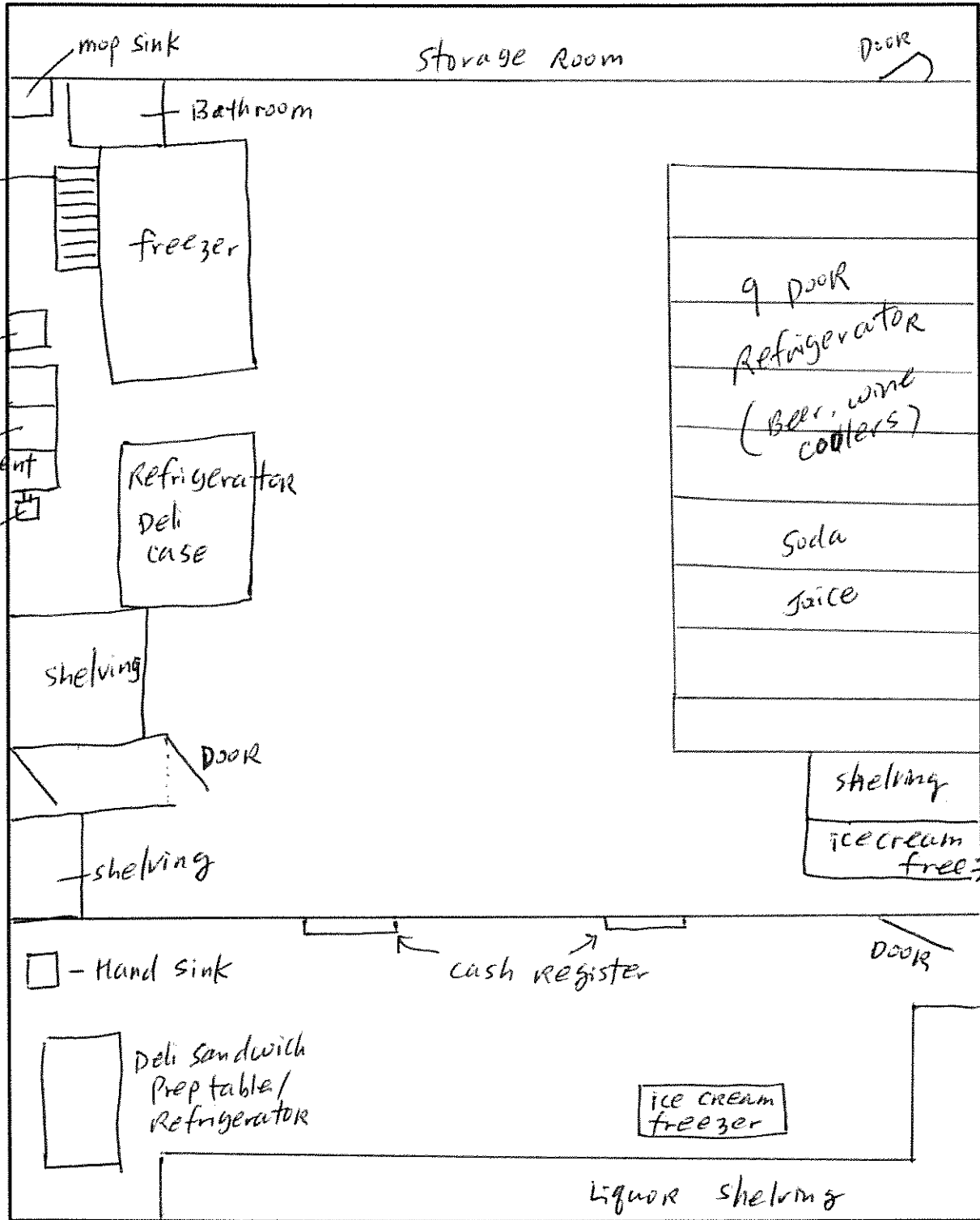

RECEIVED

2017 FEB -2 PM 4: 02

BOARD OF LIQUOR
LICENSING COMMISSIONERS

Law Office of
JAY S. YOO, P.C.

3440 Ellicott Center Drive, Suite 202
Ellicott City, Maryland 21043

Office: (410) 465-3606
Fax: (410) 988-5390
Email: jayvoolaw@yahoo.com

Admitted in Maryland

Via Facsimile (410-396-4382)

Via Electronic Mail (Thomas.Akras@baltimorecity.gov)

via First class mail

January 30, 2017

Board of Liquor License Commissioners
231 E. Baltimore Street, 6th Floor
Baltimore, MD 21202

Re: Premises Address: 300 N. Gilmore; License No. LA062
Application for Transfer of Liquor License

Dear Mr. Akras:

This letter is to explain to the Board of Liquor License Commissioners the status of the Zoning Appeal with the Board of Municipal and Zoning Appeals.

On or about June 2016, an application for Use and Occupancy Permit for an Accessory Use as a Grocery Store was filed. It was denied and an appeal was filed on July 27, 2016. The hearing was held on September 6, 2016, at which time the BZMA denied the request.

However, prior to the BZMA hearing on September 6, 2016, an application to transfer liquor license from current licensee, Bao Ying Lin to Tzu Yen Yeh, was filed on August 25, 2016. The transaction only involves the transfer of stocks of the Yuan Zheng Company (Company to which the liquor license was issued) from Lin to Yeh. As the ownership of 100% of corporate interest will change, the new owner of the corporation, Mrs. Tzu Yen Yeh, is applying to be the transferee licensee.

As the accessory use for grocery store has been denied by BMZA, and an appeal has been waived, the Premises will continued to be used only as liquor store permitted under the Use and Occupancy Permit until the expiration two year period allowed under Transform Baltimore.

Attached please find revised floor diagram in light of BMZA's denial. Thank you.

Please schedule a transfer hearing before the Commissioners at your earliest convenience.

Thank you.

Sincerely,

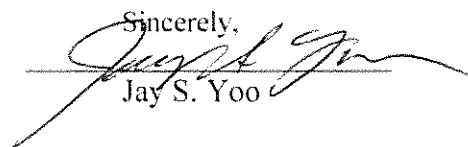
Jay S. Yoo

Enclosure:
Revised Floor Diagram

16ft

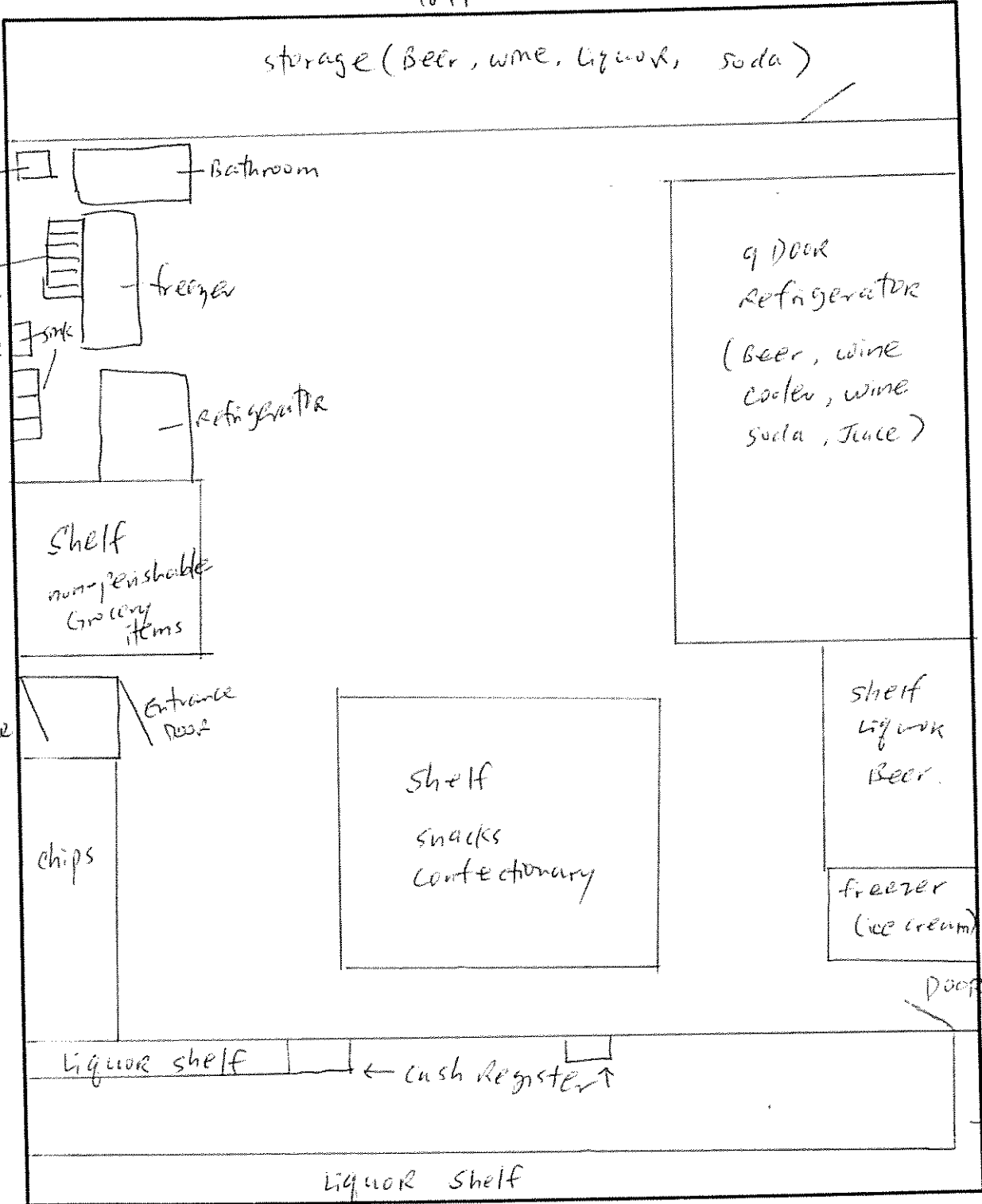

300 N. Gilmore



Liquor Board System

Version 1.0

Annual-Renewal ▾ | License-Transfer ▾ | One-Day ▾ | Add New License ▾ | Query ▾ | Help ▾

License Detail

[Close the License](#)
[Print License](#)
[Print Renewal Letter](#)
[<< Go Back](#)

License Info

License Num: **LA 035** Cert Num: **0116** Fee: **\$858.00** Status: **Renewed**
 License Date: **5/1/2016** License Year: **2016**
 CR Number: **16043774**
 Payment Date: **04-19-16**

2015 - 2016 TPP Paid
 2016 Trader's License [Update Info](#)

[Click to Start License Renewal](#)

Add Adult Entertainment License

[Add New Adult Entertainment License](#)

Location

Corp Name: **YUAN ZHENG COMPANY**
 Trade Name: **YUAN & ZHENG LIQUOR & GROCERY**
 Zone Code: **29**
 Phone: **410-566-1565**

Block Num: **300** Street: **GILMOR STREET NORTH**
 City: **BALTIMORE** State: **MD** Zip: **21223**

CR Number: **16043774**

Portion of Business Used:
 (USE) CONTINUE TO USE AS LIQUER STORE (CANGE OF OPERATER

Restriction:

[Edit the License Location Info](#) [Alternate Mailing Address](#)

License Owners

First Name	Last Name	Street	City	State	Zip	Action	Change Owner
BAO YING	LIN	2739 ASHLAND AVE	Baltimore	MD	21205	Edit	Remove Owner

Sunday License

License Num: Cert Num: Fee:
 License
 Dates:

Comments

Date	Comment	Action
04/04/2016	Attorney Mr. Yoo sent letter by fax for permission in changing Trade Name to "Yuan & Zheng Liquor & Grocery". He will be bringing a check for the \$20.00 fee.... /sb	Delete
03/11/2016	3/9/2016 Letter received by Lawyer Jay Yoo in reference to reopening after remodeling.No need for hearing licensee is given permission to reopen Per MBH	Delete
09/23/2015	Alcohol Awareness expires 08/26/19 (Bao Ying Lin)	Delete
08/19/2015	Hearing Date: 08/13/15 PAID \$100.00, Invoice #99394..../sb	Delete
08/18/2015	8/13/15 Public Hearing re: Transfer of ownership APPROVED (3-0 vote)	Delete
07/30/2015	7/30/2015 Public Hearing re Transfer of Ownership POSTPONED	Delete
06/30/2015	Withdraw of Transfer Application on June 30, 2015.... /sb	Delete
08/28/2008	08/28/08 \$500 SALE TO MINOR VIOLATION PAID IN FULL #64755	Delete

[Print History (Print Card) ...]

License num: LA 035 Address: 300 GILMOR STREET NORTH
 Trade Name: YUAN & ZHENG LIQUOR & GROCERY

Comment:

[Add Comment]

Hold Info





🏠 Maryland Business Express

[🏠 Home](#) [👤 Log In / Create Account](#)

YUAN ZHENG COMPANY: D16607731

[General Information](#) [Filing History](#) [Personal Property](#)

General Information

Department ID Number:
D16607731

Business Name:
YUAN ZHENG COMPANY

Principal Office:
300 N GILMOR ST
BALTIMORE MD 21223

Resident Agent:
BAO YING LIN
300 N GILMOR ST
BALTIMORE MD 21223

Status:
INCORPORATED

Good Standing:
THIS BUSINESS IS IN GOOD
STANDING
» [Order Certificate of Status](#)

Business Type:
CORPORATION

Business Code:
ORDINARY BUSINESS - STOCK

Date of Formation/ Registration:
06/23/2015

State of Formation:
MD

Stock Status:
STOCK

Close Status:
YES

[🔍 New Search](#) [Order Documents](#)

[Privacy and Security Policy](#) | [Accessibility Policy](#)

FOR FILING AND BUSINESS RELATED QUESTIONS

Maryland Department of Assessments & Taxation
410-767-1164 | Outside the Baltimore Metro Area: 855-248-6941
Maryland Relay: 800-735-2256

FOR TECHNICAL QUESTIONS AND SUPPORT

NIC Maryland, eGov Services Partner of the Department of Information Technology (DoIT) and Maryland.gov

PROPOSED LOCATION. 300 N. Gilmor St.

MAP SUMMARY (RECAPITULATION)

TOTAL ESTABLISHMENTS IN MAP AREA 3

"A" BEER & WINE _____

"B" BEER & WINE _____

"C" BEER & WINE _____

"D" BEER & WINE _____

"A" BEER, WINE & LIQUOR 2

"A-2" BEER, WINE & LIQUOR _____

"B" BEER, WINE & LIQUOR _____

"C" BEER, WINE & LIQUOR _____

"D" BEER, WINE & LIQUOR _____

"BD7" BEER, WINE & LIQUOR 1

ARENA _____

HOTEL/MOTEL _____

RACING _____

PREPARED BY: J. RAY Date December 15, 2017

300 N. Gilmore St.

Transfer/Ownership

Licensed Establishments

- Yuan Zheng Liquor/Grocery ABWL
- Fulton Liquor Store ABWL
- Donritz Tavern BD7

Churches and Schools

- Church of God
- New Genesis Total Praise Center
- Flat Rock Baptist Church
- Holy Faith Church
- Greater Harvest Baptist Church



Board of Liquor License Commissioners

For Baltimore City
 231 E. Baltimore Street, 6th Floor
 Baltimore, Maryland, 21202-3258

INSPECTORS REPORT - TRANSFERS/NEW APPLICATIONS

<i>Licensee Information (Trade Name):</i>	Yuan & Zheng Liquor & Grocery
<i>Corporation Name:</i>	Yuan Zheng Company
<i>Location Address:</i>	300 N. Gilmor Street
<i>License Type:</i>	Class "A" Beer, Wine and Liquor <input checked="" type="checkbox"/>
<i>Is the establishment open and operating in a safe and sanitary manner? (If not open, not in comments - CLOSED or NOT OPERATING)</i>	Yes <input checked="" type="checkbox"/>
<i>Is the location within 300 feet of Church and/or School?</i>	No <input checked="" type="checkbox"/>
<i>Date Posted?</i>	12/4/2017
<i>Date Removed?</i>	12/13/2017
<i>Are there any other licensed establishments within a two block radius?</i>	Yes <input checked="" type="checkbox"/>

Other licensed locations - Describe/Note:
 See map and recapitulation sheet.

Comments and Follow-up Items(s) (please note any issues or concerns about the location):
 This is a transfer of ownership. The liquor license has been at this location since 1935. The license was originally a Class D-BWL. In 1998 licensee requested the license be changed to a Class A-BWL and it was approved.

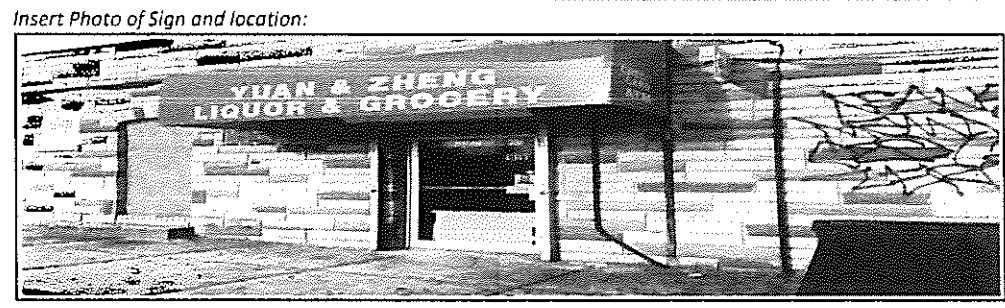

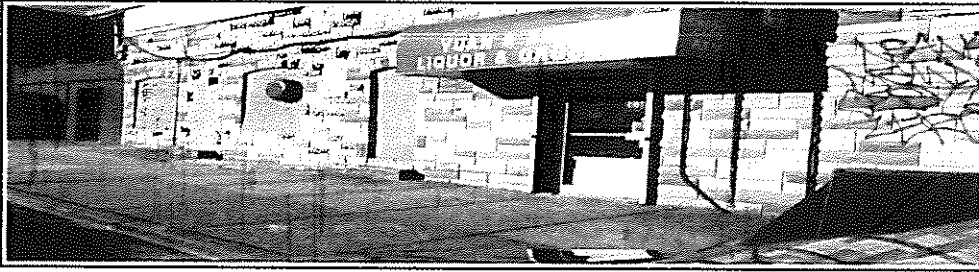

Attach Additional Photos

Inspector Name		Date and Time	
<input type="text" value="i:0#.w/baltimore/mark.fosler"/>		<input type="text" value="12/5/2017"/>	<input type="text" value="10:13:40 AM"/>
Name of licensee (if present)			
<input type="text"/>			
Submit			

Board of Liquor License Commissioners

For Baltimore City
 231 E. Baltimore Street, 6th Floor
 Baltimore, Maryland, 21202-3258

POSTING SIGNS REPORT

Applicant(s) Name:	Tzu Yen Yeh
Address of Premises:	300 N. Gilmore Street
Inspector:	i:\0#.w\baltimeore\mark.fosler
Date Posted:	12/4/2017
Time Posted:	2:15 PM
Date Rechecked:	12/13/2017
Time Rechecked:	3:00 PM
Manager or Owner when sign posted:	Ms. Jian Mei Liu

Summary on location of sign posted:

Notice posted on inside of establishment entrance.

Summary on location of sign rechecked:

Notice remains as posted.

Insert Photo of Sign and location:





Attach Additional Photos

Submit

BLLC Compliance Inspection

Licensee Information

Address: 300 GILMOR STREET NORTH 21223

Trade Name: YUAN & ZHENG LIQUOR & GROCERY

Corporation Name: YUAN ZHENG COMPANY

Type of License: Class "A" Beer, Wine and Liquor

Date/Time of Inspection: 12/6/2017 11:21:56 AM

Manager/Licensee: Xing Qi Lin

Open/Closed Status

Open/Closed: Open

Closed Date:

External Appearance

Clean and Free of Debris: Satisfactory

Business Records

Traders License: Yes

Alcohol Awareness Certification Date Issued: 5/2/2016

Public Safety

Exits Marked, Unobstructed: Yes

Fire Capacity:

Outdoor Seating Capacity:

Adult Entertainment - if Applicable

License is Valid: N/A

Violations

Violation Issued: No

Violations Noted:

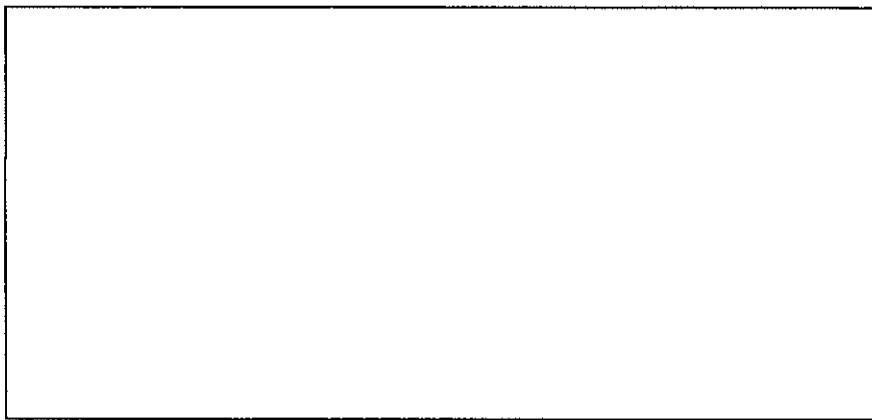

Wrap Up

Instructions Given to Licensee:

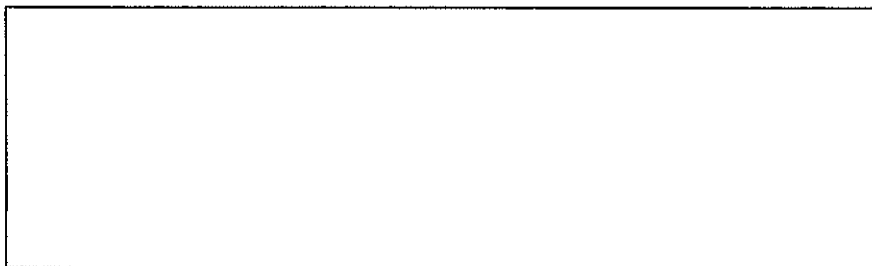

Inspector's Comments:

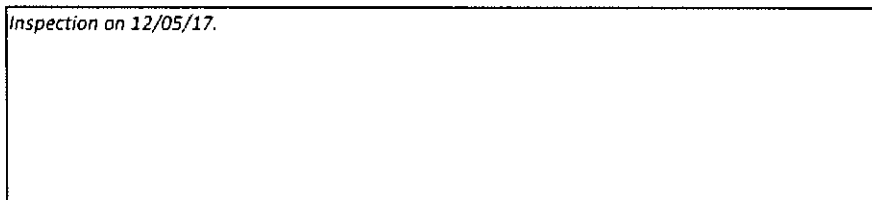
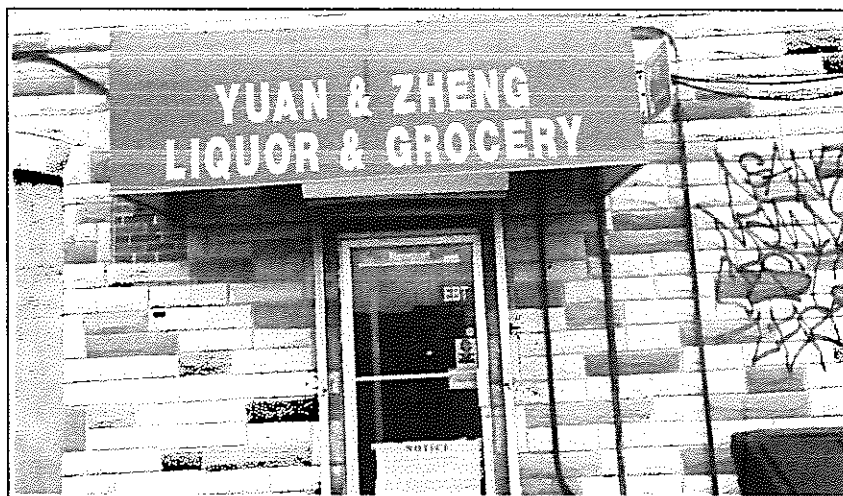
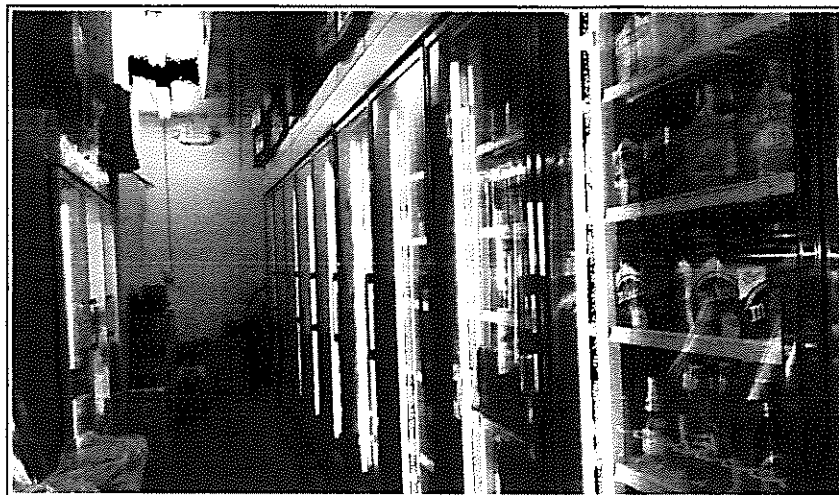

Photo Taken:





Attach Additional Photos

Owner Email:

Submitted by Inspector

[Update/Resubmit](#)

[Print View](#)

Certificate of Occupancy

WARNING: IT IS UNLAWFUL TO OCCUPY ANY WORK UNTIL INSPECTED AND APPROVED BY THIS DEPARTMENT.

WARD	SEC.	BLOCK	LOT	ISSUE DATE	DISTRICT
19	04	0150	001	9/21/15	700

PROPERTY ADDRESS: 300 N GILMOR ST

OWNER: BAO YING LIN ADDR: 300 N. GILMOR ST BALTIMORE
 LESSEE: YUAN ZHENG INC ADDR: 300 N. GILMOR ST. BALTIMORE MD

LAND USE CODES 1113 5920 0000 0000

(USE) CONTINUE TO USE AS LIQUER STORE (CHANGE OF OPERATER)

PLUMBING	45.00	ADDITIONS	
ELECTRICAL		HYDRO-PNEUMATIC TANK	
MECHANICAL		FURNISHING EQUIPMENT	
PAINT	0.00	TAX	3.00
INSULATION	50.00	TOTAL FEES	98.00

THE AUTHORITY CONTAINED HEREIN MAY NOT BE VALIDLY EXERCISED UNTIL AND AFTER ALL OF THE FEES APPEARING HEREON HAVE BEEN PAID AND EVIDENCE THEREOF APPEARS IN THIS SPACE.

Please be advised that there is a presumption of lead-based paint in properties constructed prior to 1950. Protect workers and tenants by using the lead-safe work practices found in the Code of Maryland Regulations Section 26.02.07.

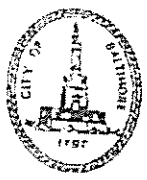

Michael Braverman
 MICHAEL BRAVERMAN
 BUILDING OFFICIAL

THE AUTHORITY CONTAINED HEREIN DOES NOT AUTHORIZE THE PERFORMANCE OF ANY WORK IN, ON, UNDER OR OVER ANY STREET, HIGHWAY, ALLEY, SIDEWALK OR ANY OTHER PUBLIC WAY UNLESS PERMISSION TO DO SO HAS BEEN FIRST SECURED FROM THE PROPER AUTHORITY.

Permit - Details

Permit Num.:USE2015-02777
 Plan Num:-
 Address:300 N GILMOR ST
 Block-Lot:0150 001(see parcel details)
 Zip Code:21223-1735

Permit Issued:9/21/2015
 Date Final:
 Date Exp:
 Last Update:6/30/2015 12:28:13 PM

Estimated Total Cost:
 Existing Use:
 Proposed Use:
 Type of Work:

Last User:AYOU
 Building Fully Sprinkler:

Tag Type	Tag Description	Updated By	Date Updated
Miscellaneous	NEW OWNER: BAO YING LIN SETTLEMENT DATE: 9-18-15 SETTLEMENT SHEET ATTACHED TO PERMIT #USE2015-02777	DFEL	9/21/2015 2:45:42 PM
Work needs perm	Work Without Permit:WORKING BEYOND SCOPE OF PERMIT, INTERIOR DEMO (by:UTTENREITHER, Insp Date: 12/2/2015)(Inspector:SHAHID)(ref#:1325232 THIS TAG WAS PUT IN BY: SYST (12-2-15) PERMIT OBTAINED AND PENALTY PAID (\$1000) UNDER COM2015-29764	KLON	12/10/2015 3:40:50 PM
Zoning Notes	BMZA2016-207 DISAPPROVED FOR THE ADDITION OF A GROCERY/DEL TO EXISTING LIQUOR STORE.	CLEE	10/3/2016 11:06:00 AM

see applicant info
 see other agency info

(USE)CONTINUE TO USE AS LIQUER STORE (CHANGE OF OPERATER)

Add Activity

Action	Notes	DISP	ASSIGNED	DATE1	DATE2	DATE3	Done By
Application Received						6/30/2015	AYOU
Zoning Sign-off		APP		6/30/2015		6/30/2015	AYOU
Use Permit Referral -Building			MADA		6/30/2015		
Building Inspection Referral					7/1/2015		
Health Department Inspection		APP	XWEL	6/30/2015		7/23/2015	XWEL
Planning Department	FRANKLIN SQ.	DONE	PLAN	6/30/2015		7/1/2015	PLAN
Filing-Draft Only		DONE				6/30/2015	LSIL
R58- Franklin Square		APP	BFLI	7/1/2015		7/7/2015	BFLI
Fire Inspection	FIRE DEPARTMENT HAS NO OBJECTION TO THE USE OF THE PREMISES AS A LIQUOR STORE CHANGE OF OPERATION	APP	AJON	7/16/2015	7/15/2015	7/15/2015	AJON
Reminder	application in use folder.	DONE				8/10/2015	DGOO
Occupancy Certification	397309-01 ~ VM - N - ENGLISH OK FOR USE LIQUER STORE	APP	REDM	8/17/2015	8/18/2015	8/18/2015	REDM
Reminder	spoke to applicant and informed him permit is ready for pick-up. application in rti use folder.	DONE				8/26/2015	DGOO
Print Draft C of O		DONE				9/21/2015	DFEL
Print C of O		DONE				9/21/2015	

[Skip navigation links](#) [Accessibility](#)

Looking for something? We can help:



BALTIMORE HOUSING

[About Us](#) [Agency Directory](#) [Plans & Reports](#) [Site Map](#) [Contact Us](#)

[Departments & Services](#)



BMZA Search Result

Record Count : 1

	Block-Lot / Address / Neighborhood	Description	Appeal Number	Conditional	Date Filed	Hearing	Decision	Council Dist
See Documents	0150-001 300 N GILMOR ST FRANKLIN SQUARE	CONTINUE LIQUOR STORE, ADDING GROCERY AND DELI ON FIRST FLOOR OF PREMISES	BMZ2016-00207	N	06/17/2016	9/6/2016 Held	9/20/2016 Denied	9

[Forms](#) [Property Registration](#) [Code Enforcement](#) [Community Services](#) [Resident Services](#) [HCP](#) [Public Inquiry](#) [Document Central](#)

[Developers](#) [Jobseekers](#) [Contractors](#) [Homebuyers](#) [Landlords](#) [Residents](#)

[Mayor Stephanie Rawlings-Chester](#)

[Home](#) [Site Map](#)

Visit BaltimoreCity.gov

COPY

IN THE MATTER OF THE
PETITION OF: YUAN ZHENG
COMPANY

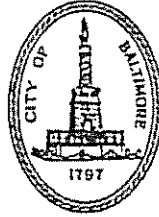

Baltimore City Board of Municipal
& Zoning Appeals

David C. Tanner
Executive Director
417 E. Fayette Street, 14th floor
Baltimore, MD 21202
Phone: 410-396-4301

300 NORTH GILMOR STREET

Appeal No. 2016-207
Hearing Date: September 6, 2016

SEP 20 2016

RESOLUTION

This matter comes before the Board on appeal from the decision of the Zoning Administrator for Baltimore City to deny Yuan Zheng Company's ("Petitioner" or "Appellant") application to add a grocery store and delicatessen as accessory to the existing first floor liquor store.

BACKGROUND

This property is located in an R-8 Zoning District and is currently improved by a three-story masonry semi-detached building with current authorized use as a liquor store with package goods and a single-family dwelling.

Appellant filed this appeal to the Board on June 17, 2016, and appeared for a public hearing on September 6, 2016. No one appeared in opposition but the file contains a letter in opposition from a community member, as well as a petition signed by numerous members of the community in support of this application. Board staff and the Planning Department prepared memoranda evaluating the appeal.

DISCUSSION

Appellant proposes to add a grocery store and delicatessen as accessory to the existing first floor liquor store. Under ZC §§4-1101, 4-1102, and 4-1103, grocery stores and delicatessen are not listed as a permitted, conditional, or accessory use. Under ZC §3-106, any use that is not expressly allowed in a district is prohibited. In a prior appeal (BMZA 97x-350) to use the first floor of these premises as a grocery store with package liquor sales, the Board approved the requested use with the condition that the entire store would be used as a liquor store and not a grocery store on (approved 1/6/1998).

Under ZC13-405(b)(1), in accordance with Subtitle 7 {"Modifications and Continuances by Board"} of this title, the Board may authorize a Class III nonconforming use in a Residence or Office-Residence District to be changed to a use permitted in a B-1 District. Grocery stores and delicatessens are listed as permitted uses in the B-1 District (ZC§6-206), and so are eligible for a change in nonconforming use. However, this property is located within the Franklin Square Urban Renewal Area where the Urban Renewal Plan restricts nonconforming uses under Section B(1)(h)(3), stating: "no non-complying land use shall be changed to any other non-complying use." As the existing liquor store constitutes a non-complying land use under this Plan, and the request to add a grocery store and delicatessen (even as accessory) uses to the existing liquor store would be a change in nonconforming use, such a change would not be permitted under the Franklin Square Urban Renewal Plan.

For the reasons set forth above, and after giving public notice, reviewing the zoning records, holding a public hearing, considering all data submitted, and by authority of Ordinance No. 1051, approved April 21, 1971, known as the Zoning Ordinance, it is this 19th day of September, 2016, by the Baltimore City Board of Municipal and Zoning Appeals, hereby

RESOLVED, that Petitioner's request to add a grocery store and delicatessen as accessory to the existing first floor liquor store is **DENIED**.

DO NOT START WORK OR USE THE PROPERTY UNTIL YOU OBTAIN A BUILDING OR A USE & OCCUPANCY PERMIT FROM THE DEPARTMENT OF HOUSING AND COMMUNITY DEVELOPMENT. YOU HAVE ONE YEAR FROM THE DATE OF THIS RESOLUTION TO OBTAIN A BUILDING PERMIT OR A USE & OCCUPANCY PERMIT.

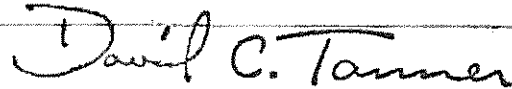

David C. Tanner
 Executive Director
 Board of Municipal & Zoning Appeals



January 4, 2018

Applicant(s): Cassandra Raymond
CKJ, Inc., T/a Get It Inn
1401 E. Clement Street 21230

Class: "B" Beer, Wine & Liquor License

Application to transfer ownership with continuation of outdoor table service.

(a) **Applicant(s) Information:** (1) Cassandra Raymond was born in Brooklyn, NY in December of 1984. She lives in Baltimore, MD.

(b) **Ownership Breakdown:** (1) Cassandra Raymond (50%); and (2) James Samuels (50%).

(c) **Purchase Price of Business:** The purchase price of the business was \$45,000. A down payment of \$4,500 was made. \$41,500 to be paid at settlement.

(d) **Qualified Voters:** Michael Johnson, Reco Collins, and Janelle Butler are qualified Baltimore City voters.

(e) **Zoning:** Applicants have applied for a USE permit, for the continued use of the property as a restaurant without live entertainment .Portion of premise for accessory outdoor table service with conditions. Outdoor services to stop at 9:30 p.m.

(f) **Corporate Standing:** CKJ, Inc. is a MD Corporation and as of 12/21/2017 is active and in good standing.

(g) **Posting Report:** The location was posted on 12/4/2017, and checked on 12/13/2017. This meets the 10-day rule. There are 6 licensed liquor establishments in the 4x4 area: "C" BWL-1; "D" BWL-1; and "BD7" BWL-4.

(h) **Timeline:** Last Inspection by BLLC was performed 11/29/2017. At that time, the establishment was open and operating.

(i) **Letters of Support/Opposition:** At this time the Board has no letters of support or opposition.

In considering this request, under the provisions of Alcohol Beverage Article 4-210(A) the Board must consider the following factors: 1. The public need and desire for the license; 2. The number and location of existing license holders; 3. The potential effect on existing license holders of the license for which application is made; 4. The potential commonality or uniqueness of the services and products to be offered by the business of the applicant; 5. The impact of the license for which application is made on the health, safety, and welfare of the community, including issues relating to crime, traffic conditions, parking, or convenience; and 6. Any other factor that the local licensing Board considers necessary.

Board's Decision:

Application for Alcoholic Beverages License Board of Liquor License Commissioners for Baltimore City

NEW/TRANSFER/EXPANSION/AMENDMENT(S) APPLICATION FEE - \$600.00

***Place cursor on the field to enter text Do Not tab.

INDICATE TYPE OF LICENSE APPLICATION: TRANSFER NEW EXPANSION OF PREMISES AMENDMENT(S)

EXPLANATION OF REQUEST: transfer of ownership CLASS TYPE: LB

IF NEW LICENSE REQUEST, THEN ADDRESS OF PROPOSED LOCATION: N/A

IF TRANSFER OF OWNERSHIP ONLY, THEN ADDRESS OF CURRENT LICENSE: 1401 E. Clement St. 21230

IF TRANSFER OF OWNERSHIP AND LOCATION, THEN CURRENT ADDRESS OF LICENSED LOCATION: N/A

IF TRANSFER OF OWNERSHIP AND LOCATION, THEN ADDRESS OF PROPOSED RELOCATION: N/A

CORPORATE/LLC/LLP/PARTNERSHIP NAME: CKJ, Inc. TRADE NAME: Get It Inn

BUSINESS PHONE NUMBER: 410 685-5100 BUSINESS EMAIL ADDRESS: _____

ATTORNEY FOR THE APPLICANT: Melvin J. Vlodenski ADDRESS: 19 E. Fayette St. Ste. 400, 21202 PHONE: 410 685-5100

Part of Premises Used (Note: Floors and Areas for Storage): 1st and 2nd Floors business and basement for storage

Live Entertainment provided? Yes No What Kind (Ex. DJ, Band, Etc.): and 2nd FL storage

Outdoor Table Service Provided? Yes No Off Premise Catering of Food and Alcohol? Yes No Catering Application filed with BLLC? Yes No

Delivery of alcohol? Yes No Zoning Receipt or Current Certificate of Occupancy Permit attached to Application? Yes No

Please note that as per Alc. Bev. Art. § 12-1407(A)(2), an application for the issuance or transfer, is not complete unless the applicant has obtained approval and/or verification from the Baltimore Municipal Zoning Administration (BMZA)

1. Applicant A

Cassandra Raymond (Full name) [Redacted] (Telephone no.) [Redacted] E-mail (Required)

118 N Howard St. (Residence) Street Baltimore MD 21201 City State Zip Code 27 months (period of residency in Baltimore City)

12/1984 (Month/Year of Birth) Female (Sex: Male or Female) Brooklyn, NY (Place of Birth)

Check: Yes No Have you been a resident and taxpayer of the City of Baltimore for 2 years preceding this application?
 Yes No Are you a registered voter in the City of Baltimore?

2. Applicant B

(Full name) _____ (Telephone no.) _____ E-mail (Required) _____

(Residence) Street _____ City _____ State _____ Zip Code _____ (period of residency in Baltimore City) _____

(Month/Year of Birth) _____ (Sex: Male or Female) _____ (Place of Birth) _____

Check: Yes No Have you been a resident and taxpayer of the City of Baltimore for 2 years preceding this application?
 Yes No Are you a registered voter in the City of Baltimore?

3. Applicant C

(Full name) _____ (Telephone no.) _____ E-mail (Required) _____

(Residence) Street _____ City _____ State _____ Zip Code _____ (period of residency in Baltimore City) _____

(Month/Year of Birth) _____ (Sex: Male or Female) _____ (Place of Birth) _____

Check: Yes No Have you been a resident and taxpayer of the City of Baltimore for 2 years preceding this application?
 Yes No Are you a registered voter in the City of Baltimore?

1. Has the applicant(s) been adjudged guilty of a felony in the State of Maryland or any other? Yes No - If yes, indicate applicant and explain.

Applicant A B C

2. Has the applicant(s) been adjudged guilty of violating the laws governing the sale of any alcoholic beverage or for gambling in any State, including Maryland? Yes No - If yes, mark applicant and provide an explanation in adjacent space provided.

Applicant A B C

3. State whether the applicant(s) has ever been adjudged guilty of any offense against the laws of the State of Maryland, any other State within the United States, or against the United States (Federal Crime)? Yes No - If yes, mark applicant and explain.

Applicant A B C

4. Has the applicant(s) ever had a license for the sale of alcoholic beverages in the State of Maryland? Yes No If yes, mark applicant and explain.

Applicant A B C

5. Has the applicant(s) ever had a liquor license suspended or revoked? Yes No If yes, mark applicant and explain.

Applicant A B C

6. Does the applicant(s) have a financial interest in any other alcoholic beverage business or business for which an alcoholic beverage license has been applied for, granted, and issued? Yes No If yes, mark applicant and explain.

Applicant A B C

7. Do the spouses or children of any of the applicant(s) have a financial interest in any other alcoholic beverages license or business in Baltimore City or any other jurisdiction in the State of Maryland? Yes No If yes, mark applicant and explain.

Applicant A B C

8. Are you financially interested in any other alcoholic beverages license applied, granted or issued? Yes No If yes, please explain.

Applicant A B C

9. Is the licensed premise currently open and operating? Yes No If no, then please explain when the establishment ceased operations.

10. Do any of the applicant(s) - personally or through an entity - have any indebtedness or other financial obligations to any manufacturer, brewer, distiller, or wholesaler at the time of making this application? Yes No If yes, please explain. If yes, please provide information as to the applicant(s) indebted - personally or through an entity - the amount of the indebtedness, and the name of the manufacturer, brewer, distiller, or wholesaler?

Applicant A B C

11. Please list the following information for the Manager of the establishment to be licensed:

Name	Address	Phone	Email
Cassandra Raymond	118 N Howard St	[REDACTED]	[REDACTED]

Applicants Applying as Business Entities - (Give name(s) and addresses - in Corporation list all officers (attach list if necessary) or in Limited Liability Company/Partnerships list all authorized persons.) *Please note that all licensees MUST have a FINANCIAL INTEREST in the license applied for as per Alc. Bev. Art. § 4-109 (e)(II). If necessary, please attach a list of the names and address of all outstanding stock holders who at the time of application own more than 5% of the outstanding stock of the corporation and the articles of incorporation, partnership agreement or articles of organization.*

- 1) NAME: Cassandra Raymond ADDRESS: 118 N. Howard St TITLE: President %OF STOCK HELD: 50%
 2) NAME: Samuel Samuel ADDRESS: 2507 Talbot Rd TITLE: Vice Pres %OF STOCK HELD: 50%
 3) NAME: _____ ADDRESS: _____ TITLE: _____ %OF STOCK HELD: _____
 4) NAME: _____ ADDRESS: _____ TITLE: _____ %OF STOCK HELD: _____

**Extract from Law: If any affidavit or oath required under the provisions of this Act shall contain any false statements, the offender shall be deemed guilty of perjury. And upon indictment and conviction thereof, shall be subject to penalties provided by Law for that crime.*

CERTIFICATE OF APPLICANTS: At least one applicant whose signature appears below certifies that he/she has been a resident and taxpayer of Baltimore City, Maryland for at least two years preceding the filing of this application. Each of said applicants hereby certifies further that if the license applied for is granted, he/she will conform to all State and County laws and regulations relating to the sale of alcoholic beverages, as well as to the rules and regulations of the Board of License Commissioners for Baltimore City, and hereby grants permission to the State Comptroller, his duly authorized deputies, inspectors and clerks, the Board of License Commissioners for Baltimore City, its duly authorized agents and employees, and any peace officer of Baltimore City or the State of Maryland to inspect and search at any and all hours, without warrant, the premises and any and all parts thereof upon and in which said business is to be conducted.

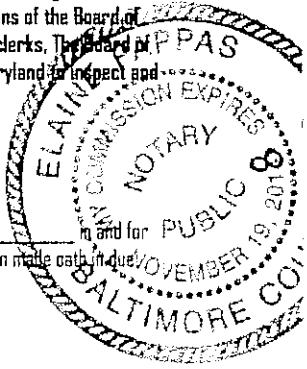

Cassandra Raymond
 Signature of Applicant A

I hereby certify that on the 3rd day of Nov, 2017, before me, the subscriber, a notary public of the State of Maryland in and for Balto. Co., personally appeared Cassandra Raymond the applicant(s) named in this renewal application made oath in due form of law that the matter and facts contained in said application are true and correct. As witness, my hand and notarial seal.

Signature: Elaine Pappas (Notary Seal) My Commission expires 11/19/18
 Printed Name: Elaine Pappas

Signature of Applicant B

I hereby certify that on the _____ day of _____, 20____, before me, the subscriber, a notary public of the State of _____ in and for _____, personally appeared _____ the applicant(s) named in this renewal application made oath in due form of law that the matter and facts contained in said application are true and correct. As witness, my hand and notarial seal.

Signature: _____ (Notary Seal) My Commission expires _____
 Printed Name: _____

Signature of Applicant C

I hereby certify that on the _____ day of _____, 20____, before me, the subscriber, a notary public of the State of _____ in and for _____, personally appeared _____ the applicant(s) named in this renewal application made oath in due form of law that the matter and facts contained in said application are true and correct. As witness, my hand and notarial seal.

Signature: _____ (Notary Seal) My Commission expires _____
 Printed Name: _____

1401 East Clement Street, LLC

1401 E. Clement St; 21230

Name and Address of the owners of the premise/landlord: by: John Ferrari, Jr. Phone Number: [REDACTED]

STATEMENT OF OWNER OF PREMISES REQUIRED IN CONNECTION WITH ALCOHOLIC BEVERAGES LAW OF MARYLAND

(I, WE) John Ferrari, Jr. Member of 1401 East Clement Street, LLC HEREBY CERTIFY, That (I am, we are) the owner(s) of the property located at 1401 E. Clement Street, Baltimore, City with a Zip Code of 21230, which is named in the present application made to Board of Liquor License Commissioners of Baltimore City under the Alcoholic Beverage Laws of Maryland and assent to the granting of the license applied for, and hereby authorize the State Comptroller, his duly authorized deputies, inspectors and clerks, the Board of Liquor License Commissioners of Baltimore City, its duly authorized agents and employees, and any peace officer of the City of Baltimore and State of Maryland, to inspect and search, without warrant, the premises upon which the business is to be conducted, and any and all parts of the building in which said business is to be conducted, at any and all hours.

I hereby certify that on the 2nd day of Nov. 2017, before me, the subscriber, a notary public of the State of Maryland, in and for Balto. Co., personally appeared John Ferrari, Jr. member the applicant(s) named in this renewal application made oath in due form of law that the matter and facts contained in said application are true and correct.

As witness, my hand and notarial seal.

Signature: Elaine Pappas
Printed Name: Elaine Pappas

[Notary Seal] My Commission expires 11/19/18

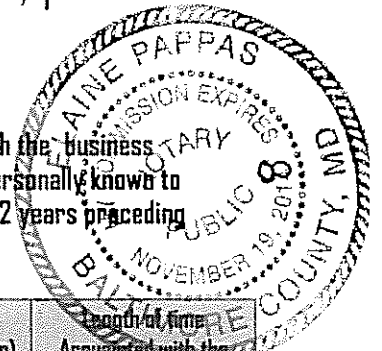

The following certificates must be signed by at least 3 persons.

We, the undersigned citizens, real estate owners and registered voters in the City of Baltimore in which the business covered by the present application is to be conducted, certify that the qualifying applicant(s) is/are personally known to us and has been a resident or a taxpayer of Baltimore City and a resident of the State of Maryland for 2 years preceding this application.

Names	Address	Signature	DOB (Month/Year)	Length of time Acquainted with the Applicant(s)
Michael Johnson	11 N. Wickham 3122 Rd	<i>M Johnson</i>	6-66	20 yrs
Reco Collins	5876 Pimlico 21209 Rd	<i>Reco Collins</i>	2-83	4 yrs
Janelle Butler	1914 Eutaw Pl 21217	<i>J Butler</i>	3-76	19 yrs
Tony MURRAY	3501 Milford Ave 21207	<i>Tony Murray</i>	8-81	7 yrs.

Board of Liquor License Commissioners for the City of Baltimore
231 East Baltimore Street, 6th Floor, Baltimore, Maryland 21202
Phone: 410-396-4377 Fax: 410-396-4382

Please note that this is a public document and upon request will be provided to the general members of the public.

2017 NOV -6 AM 10:22

RECEIVED

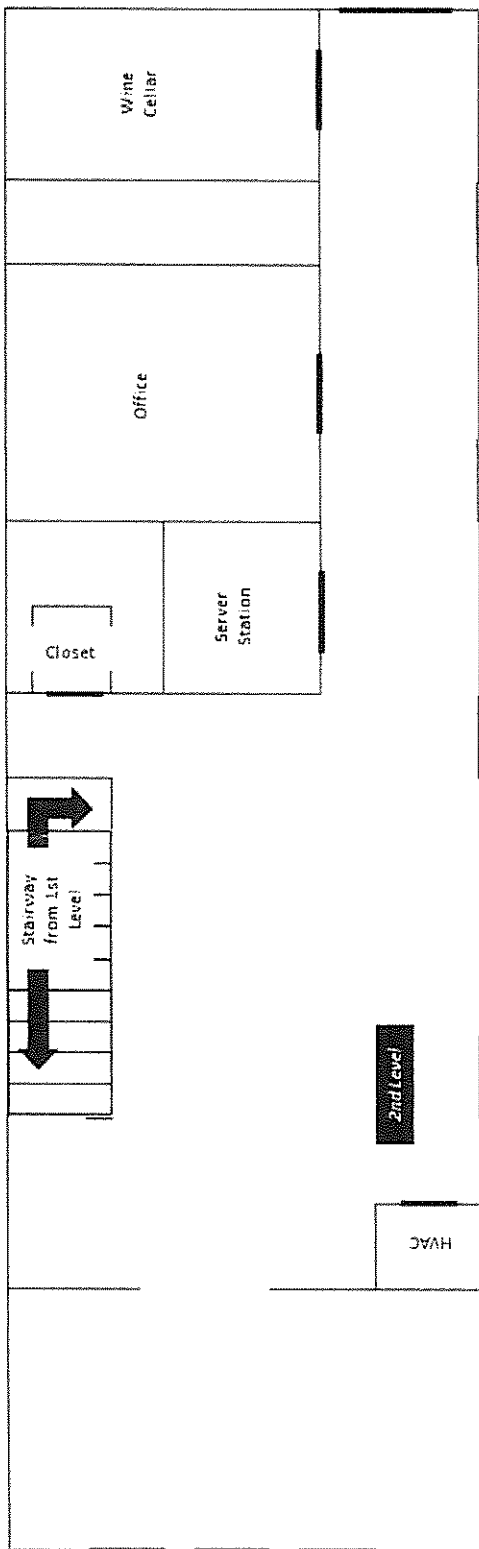
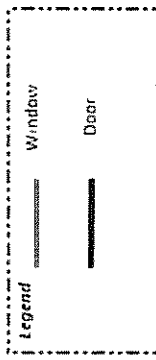
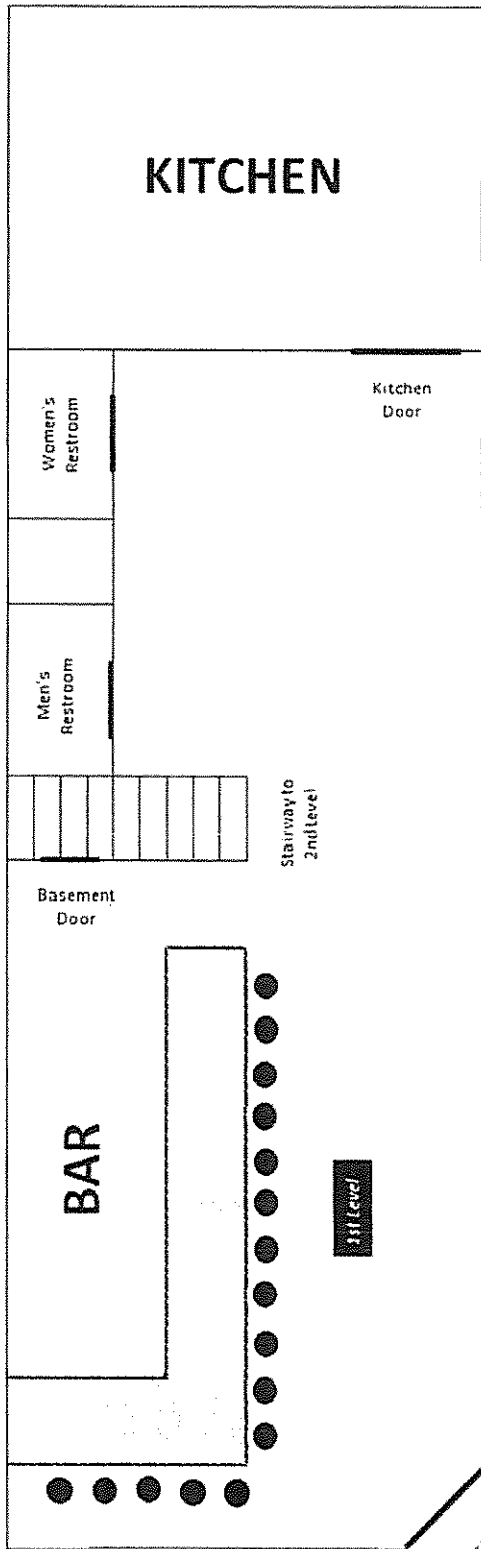

Table

Table

Storefront



Liquor Board System

Version 1.0

Annual-Renewal ▼ | License-Transfer ▼ | One-Day ▼ | Add New License ▼ | Query ▼ | Help ▼

License Detail

License Info

License Num: **LB 114** Cert Num: **0131** Fee: **\$1,520.00** Status: **Renewed**
 License Date: 5/1/2017 License Year: 2017
 CR Number: 15260309
 Payment Date: 04-28-17

2016 - 2017 TPP Paid
 2017 Trader's License

Document not available

Add Adult Entertainment License

Location

Corp Name: **JMF HOLDING, LLC**
 Trade Name: **SWEET CAROLINE'S**
 Zone Code: 8
 Phone: 410-244-1401

Block Num: 1401 Street: CLEMENT STREET EAST
 City: BALTIMORE State: MD Zip: 21230

CR Number: 15260309

Portion of Business Used:
 CONTINUE TO USE AS A RESTAURANT/ TAVERN WITH OUTDOOR TABLE SERVICE CHANGE OF OWNERSHIP

Restriction:
 UNDER THE PROVISIONS OF ARTICLE 2B, SECTION 6-201(d)(1)(vii) & (viii), LICENSEE MUST HAVE 51% FOOD SALES AND UNDER ARTICLE 2B, SECTION 6-201(d)(1)(v), LICENSEE MAY NOT SELL PACKAGE GOODS.

License Owners

First Name	Last Name	Street	City	State	Zip	Action	Change Owner
JOHN M.	FERRARI, JR.	1634 Clement St	Baltimore	MD	21230	<input type="button" value="Edit"/>	<input type="button" value="Remove Owner"/>

Comments

Date	Comment	Action

10/02/2017	***PERSONAL PROPERTY TAX OWED TO CITY OF BALTIMORE, letter sent to Licensee on October 2, 2017.*** /mb	Delete
09/26/2017	Mailed letter of recognition for underage drinking compliance check on 6/14/17 /kk	Delete
05/12/2017	***RELEASED STATE OF MD TAX HOLD***.../sb	Delete
04/28/2017	2017 FOOD FORM WAS COLLECTED THE TIME OF LICENSE FEE WAS PAID....K/R	Delete
01/18/2017	*****STATE OF MD TAX HOLD, letter sent to Licensee on January 17, 2017.***** /sb	Delete
09/13/2016	Letter sent on 9/2/2016 in reference to 2016 food form submission. Establishment had 10 days from that date of letter to submit the form. At this time there has been no response....k.r	Delete
04/30/2015	RELEASED STATE OF MD TAX HOLD..... /sb	Delete
02/03/2015	State of MD Tax Hold, letter sent to merchant on January 23, 2015.	Delete
06/11/2013	06/06/2013 Public Hearing re: Application to transfer ownership,add live entertainment and outdoor table service. Board CONDITIONALLY APPROVED transfer with additions subject to community support.	Delete
05/24/2013	4/4/2013 Public Hearing re: Status of license. LICENSE VIABLE.	Delete
12/27/2012	12/20/2012 Public Hearing re: Request for hardship extension. GRANTED 180day extension from hearing date.	Delete
11/15/2012	10/16/12 Consent for transfer withdrawn by sellers; application voided.	Delete
05/24/2012	5/17/2012 Public Hearing re: Application to transfer ownership where licensed premises has been closed for more than 90 days. Board CONDITIONALLY APPROVED transfer subject to meeting with Locust Point Civic Association.	Delete
04/17/2012	4/12 Transfer of ownership, B-BWL restaurant license, Patrick M. Hudson, Glen Arm Family of Foods	Delete
10/11/2011	10/6/2011 Public Hearing re: Request to reopen. POSTPONED.	Delete
08/25/2011	8/18/11 Public Hearing re: Request for a hardship extension under the provisions of Article 2B section 10-504(d). GRANTED 180 day extension from 8/18/11	Delete

Print History (Print Card)

License num: LB 114 Address: 1401 CLEMENT STREET EAST
 Trade Name: SWEET CAROLINE'S

Comment:

Add Comment

Hold Info

Powered by:





⊖ Maryland Business Express

[Home](#) [Log In / Create Account](#)

CKJ INC.: D14632285

- General Information**
- Filing History
- Personal Property

General Information

Department ID Number:

D14632285

Business Name:

CKJ INC.

Principal Office:

1401 E. CLEMENT ST
BALTIMORE MD 21230

Resident Agent:

CASSANDRA RAYMOND
118 N. HOWARD ST.
APT 404
BALTIMORE MD 21202

Status:

REVIVED

Good Standing:

THIS BUSINESS IS IN GOOD
STANDING

» [Order Certificate of Status](#)

Business Type:

CORPORATION

Business Code:

ORDINARY BUSINESS - STOCK

Date of Formation/ Registration:

04/19/2012

State of Formation:

MD

Stock Status:

STOCK

Close Status:

YES

[New Search](#) [Order Documents](#)

[Privacy and Security Policy](#) | [Accessibility Policy](#)

FOR FILING AND BUSINESS RELATED QUESTIONS

Maryland Department of Assessments & Taxation

410-767-1184 | Outside the Baltimore Metro Area: 888-246-9941

Maryland Relay: 800-735-2258

PROPOSED LOCATION: 1401 E. CLEMENT

MAP SUMMARY (RECAPITULATION)

TOTAL ESTABLISHMENTS IN MAP AREA 6

"A" BEER & WINE _____

"B" BEER & WINE _____

"C" BEER & WINE _____

"D" BEER & WINE _____

"A" BEER, WINE & LIQUOR _____

"A-2" BEER, WINE & LIQUOR _____

"B" BEER, WINE & LIQUOR _____

"C" BEER, WINE & LIQUOR 1

"D" BEER, WINE & LIQUOR 1

"BD7" BEER, WINE & LIQUOR 4

ARENA _____

HOTEL/MOTEL _____

RACING _____

PREPARED BY: Jean Martin DATE: 12/05/17

1401 E. Clement St.

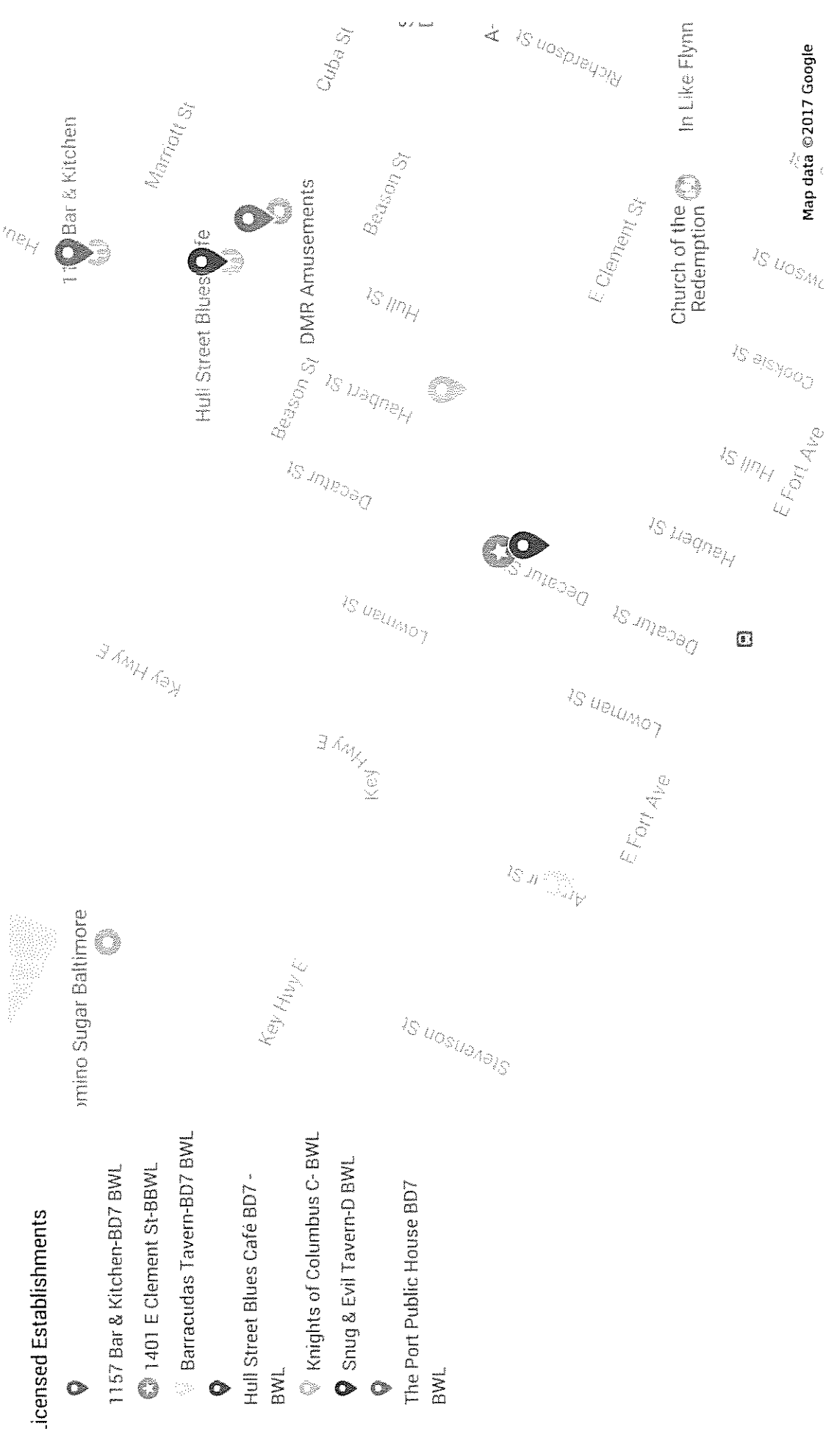

Licensed Establishments

 1157 Bar & Kitchen

 Hull Street Blues Cafe

 Church of the Redemption

 Barracudas Tavern

 Hull Street Blues Cafe

 Knights of Columbus

 Snug & Evil Tavern

 The Port Public House

Board of Liquor License Commissioners

For Baltimore City

231 E. Baltimore Street, 6th Floor
Baltimore, Maryland, 21202-3258

INSPECTORS REPORT - TRANSFERS/NEW APPLICATIONS

<i>Licensee Information (Trade Name):</i>	Cassandra Raymond/ Get It Inn
<i>Corporation Name:</i>	CKJ, Inc.
<i>Location Address:</i>	1401 E. Clement St.
<i>License Type:</i>	Class "B" Beer, Wine and Liquor
<i>Is the establishment open and operating in a safe and sanitary manner? (If not open, not in comments - CLOSED or NOT OPERATING)</i>	Yes
<i>Is the location within 300 feet of Church and/or School?</i>	No
<i>Date Posted?</i>	12/4/2017
<i>Date Removed?</i>	
<i>Are there any other licensed establishments within a two block radius?</i>	Yes

Other licensed locations - Describe/Note:

see Map

Comments and Follow-up Items(s) (please note any issues or concerns about the location):

Filed application for transfer of ownership with continuing outdoor table service
First and Second Floor for Business and basement for storage

Insert Photo of Sign and location:



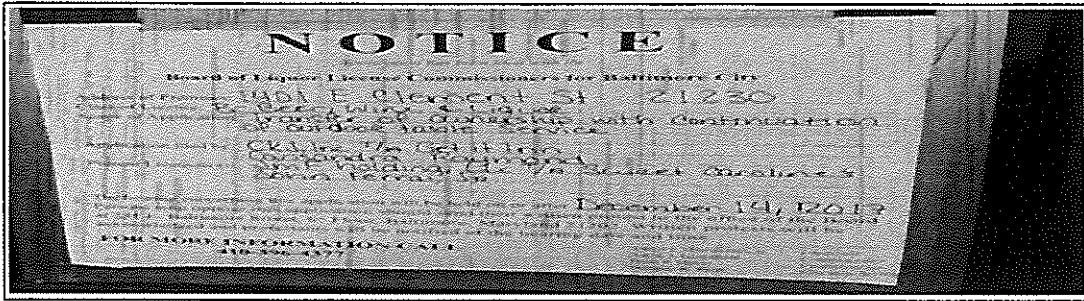

BLLC Compliance Inspection

Address: 1401 CLEMENT STREET EAST 21230

Trade Name: SWEET CAROLINE'S

Corporation Name: JMF HOLDING, LLC

Type of License: Class "B" Beer, Wine and Liquor

Date/Time of Inspection: 11/29/2017 12:04:39 PM

Manager/Licensee: C. Raymond

Open/Closed: Open

Closed Date:

Clean and Free of Debris: Satisfactory

Traders License: N/A

Alcohol Awareness Certification Date Issued:

Exits Marked, Unobstructed: Yes

Fire Capacity:

Outdoor Seating Capacity:

License is Valid: N/A

Violation Issued: No

Violations Noted:

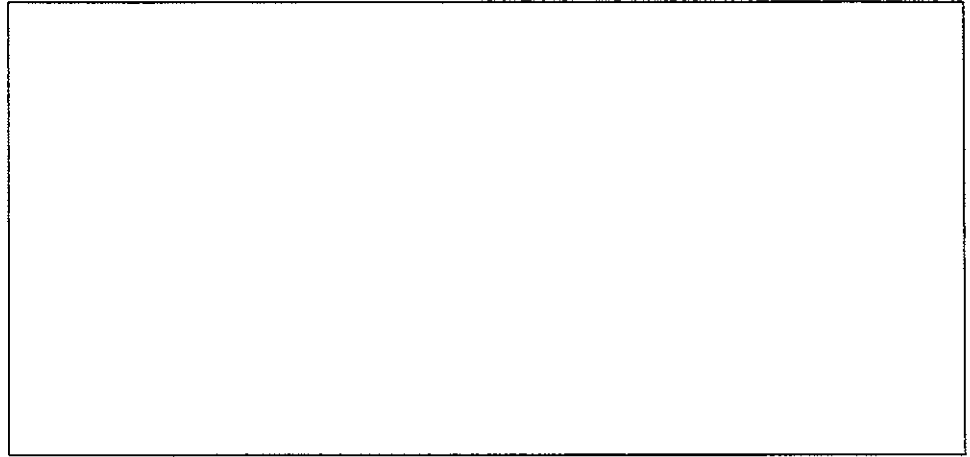
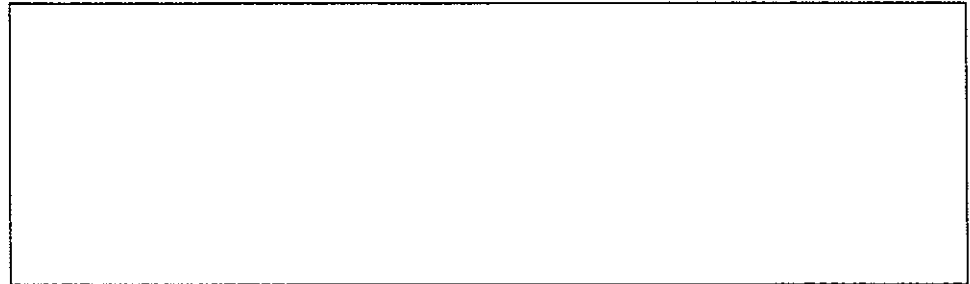

Photo:

Instructions Given to Licensee:



Inspector's Comments:

Application filed for transfer of ownership in November 06, 2017
Operating under management agreement (Get It Inn Island Bar)
temporary Health permit
date of compliance 11/28/17

Photo Taken:

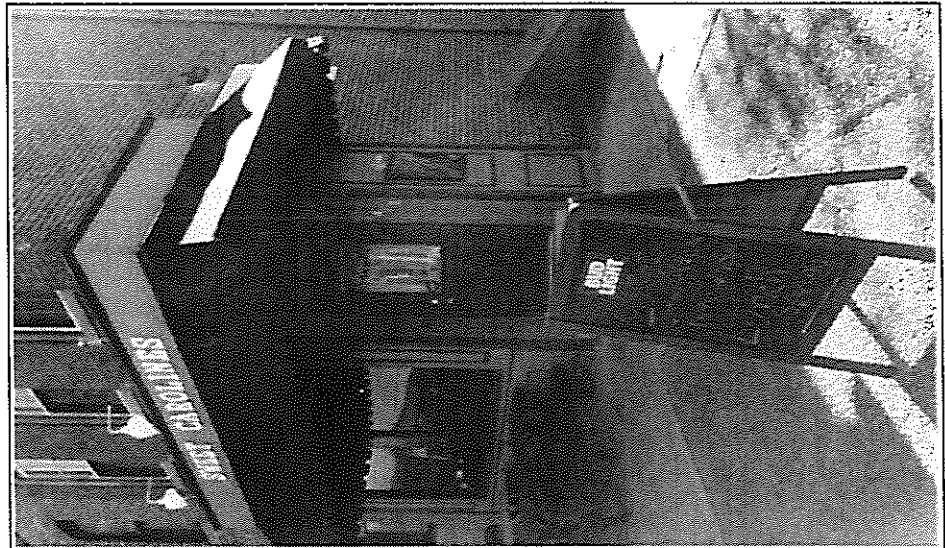

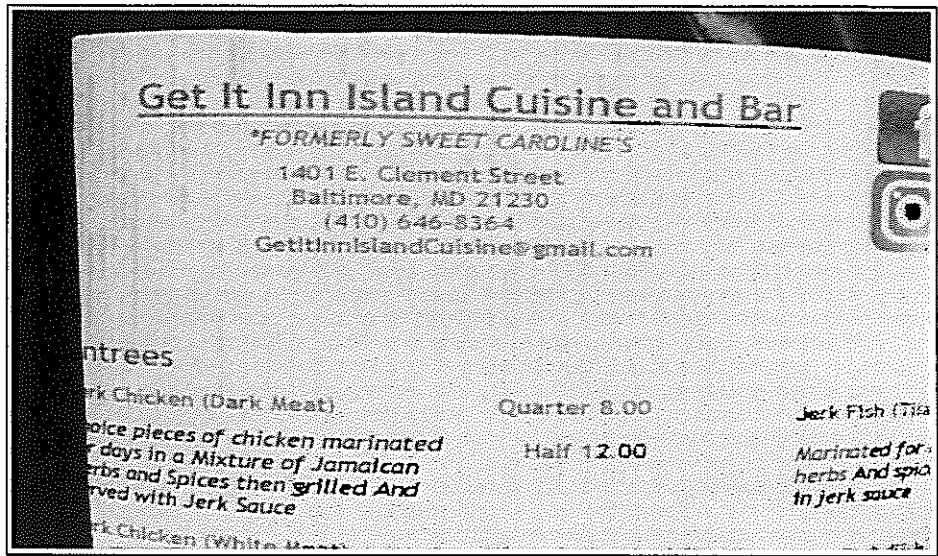

Owner Email:

Submitted by Inspector

Permit - Details

Permit Num.:USE2017-53740
 Plan Num:-
 Address:1401 E CLEMENT ST
 Block-Lot:2019A046(see parcel details)
 Zip Code:21230-5205

Permit Issued:
 Date Final:
 Date Exp:
 Last Update:10/31/2017 1:17:19 PM

Estimated Total Cost:

Last User:LEEC

Existing Use:
 Proposed Use:
 Type of Work:

Building Fully Sprinkler:

Tag Type	Tag Description	Updated By	Date Updated
Zoning Block (W)	BMZA filed to add accessory outdoor table to existing restaurant/tavern.- o/k per bmza458-07 app5-29-07	TCOZ	6/22/2007 12:46:42 PM
Miscellaneous	1401 E CLEMENT ST LLC TOOK OWNERSHIP ON 6-14-13 SETTLEMENT SHEET ATTACHED TO COM2013-14158 PER LS ON 7-10-13	LSIL	7/10/2013 2:30:22 PM

[see applicant info](#)
[see other agency info](#)

(CHANGE OF OPERATOR)CONTINUE TO USE FIRST AND SECOND FLOOR AS RESTAURANT WITHOUT LIVE ENTERTAINMENT AND USE PORTION OF PREMISES FOR ACCESSORY OUTDOOR TABLE SERVICE WITH CONDITIONS. OUTDOOR SERVICES TO STOP AT 9:30PM. TABLE REMOVED BY 10:30PM

Add Activity

Action	Notes	DISP	ASSIGNED	DATE1	DATE2	DATE3	Done By
Application Received						10/31/2017 1:17:00 PM	CLEE
Zoning Sign-off		APP		10/31/2017 1:17:00 PM		10/31/2017 1:17:00 PM	CLEE
REMINDER	Please check Parcel Tag(s).			10/31/2017 1:17:00 PM			
REMINDER	Please check Parcel Tag(s).			10/31/2017 1:17:00 PM			
HEALTH DEPARTMENT INSPECTION			JWEL	10/31/2017			
System Note	longk	DONE		10/31/2017 3:38:00 PM		10/31/2017 3:38:00 PM	KLON
Liquor License Transfer- BLD	751543-01 ~ VM - Y - ENGLISH	ERR	DSTO	10/31/2017	11/6/2017	11/6/2017	DSTO
Fire Inspection			AJAC	11/2/2017			
OCCUPANCY CERTIFICATION	CONTACT: 443-497-9328 RESULT: NEEDS FIRE APPROVAL, REPAIRS TO EXIT LIGHTS AND GUARDS TO BASEMENT.	FAIL	DSTO	11/6/2017	11/7/2017	11/7/2017	DSTO



Master: USE2017-53740 Record: 10/31/2017 Plans Num: -
 Address: 1401 E CLEMENT ST Status: [INS(IN)] Land User: ,3-50,,
 Ward/Section: 24-10 Issue: [Ed] [X] Proj Code: Sdat
 Block/Lot: 2019A-046 Final: Sdat
 District: 901(21230-5205) Exp: [Ed] [X]

- GIS GMap BlockPlat MHHC MHR
- All Notices on this Property

P&CE ©2009

- > My Task
- > New Task
- > Misc Due
- > Search
- > WWP
- > Report
- > Web App
- > My Bucket - Zone(14)

User ID:shiplej(ZON-40)

Question/Suggestion

Main:USE2017-53740 1401 E CLEMENT ST INS

- Main Parcel Info People Activity Fixture Fee Print BMZA Ext/Amd/Partial Ext Test
- Memo Photo/Document Online Info Message Board DGS-SWM Parcel Change All Plans All Permits

(CHANGE OF OPERATOR)CONTINUE TO USE FIRST AND SECOND FLOOR AS RESTAURANT WITHOUT LIVE ENTERTAINMENT AND USE PORTION OF PREMISES FOR ACCESSORY OUTDOOR TABLE SERVICE WITH CONDITIONS. OUTDOOR SERVICES TO STOP AT 9:30PM. TABLE REMOVED BY 10:30PM

Condition Add Condition

Type	Description	Notes	By	Updated	Dis
1	Zoning Block (W)	BMZA filed to add accessory outdoor table to existing restaurant/tavern. - o/k per bnza458-07 app5-29	TCOZ	6/22/2007 12:46:42 PM	
1	Miscellaneous	1401 E CLEMENT ST LLC TOOK OWNERSHIP ON 6-14-13 SETTLEMENT SHEET ATTACHED TO COM2013-14158 PER LS ON 7-10-13	LSL	7/10/2013 2:30:21 PM	

Permit Num	USE2017-53740	Plans Year	<input checked="" type="checkbox"/>	Exist DW	0	Prop DW	0
Plans Num		Plans Number	<input checked="" type="checkbox"/>	Exist ET	0	Prop ET	0
Parcel	Z019A046	Set Exp Date	<input checked="" type="checkbox"/>	Exist RM	0	Prop RM	0
Review Completed		Plan Rev Complete		Exist LU1	Restaurant	Prop LU1	Restaurant
Date Issue		Construction cost	<input checked="" type="checkbox"/>	Exist LU2	Restaurant	Prop LU2	<input checked="" type="checkbox"/>
Date Expires		Estimated cost	<input checked="" type="checkbox"/>	Exist LU3	<input checked="" type="checkbox"/>	Prop LU3	<input checked="" type="checkbox"/>
Date Finaled		Prop Area	<input checked="" type="checkbox"/>	Exist LU4	<input checked="" type="checkbox"/>	Prop LU4	<input checked="" type="checkbox"/>
Date Target		Prop Volume	<input checked="" type="checkbox"/>	Exist Use	(Commercial) Restaurant	Prop Use	(Commercial) Restaurant
Applicant Name	JAMES SAMUELS	Type Of Work	<input checked="" type="checkbox"/>				
Project Name		Use_Existing					
Recorded By	LEEC	Use_Propose					
Date Recorded	10/31/2017 1:17:18 PM	GreenBuilding	<input checked="" type="checkbox"/>				
Status	INS	NumOfUnit	<input checked="" type="checkbox"/>				
Frozen	N	NumOfUnit Accessible	<input checked="" type="checkbox"/>				
Update By	LEEC	NumOfUnit Adaptable	<input checked="" type="checkbox"/>				
Date Update	10/31/2017 1:17:18 PM	NumOfUnit Visitable	<input checked="" type="checkbox"/>				
Project Num	USE2017-53740						
Master Number	USE2017-53740						

Permit - Details

Permit Num.:USE2007-02649
 Plan Num:-
 Address:1401 E CLEMENT ST
 Block-Lot:[2019A046\(see parcel details\)](#)
 Zip Code:21230-5205

Permit Issued:9/21/2007
 Date Final:9/21/2007
 Date Exp:
 Last Update:6/22/2007 12:55:44 PM

Estimated Total Cost:

Existing Use:
 Proposed Use:
 Type of Work:

Last User:TCOZ
 Building Fully Sprinkler:

Tag Type	Tag Description	Updated By	Date Updated
Zoning Block (W)	BMZA filed to add accessory outdoor table to existing restaurant/tavern.- o/k per bmza458-07 app5-29-07	TCOZ	6/22/2007 12:46:42 PM
Miscellaneous	1401 E CLEMENT ST LLC TOOK OWNERSHIP ON 6-14-13 SETTLEMENT SHEET ATTACHED TO COM2013-14158 PER LS ON 7-10-13	LSIL	7/10/2013 2:30:22 PM

[see applicant info](#)
[see other agency info](#)

USE PORTION OF PREMISES FOR ACCESSORY OUT DOOR TABLE SERVICE WITH CONDITIONS - OUT DOOR SERVICES TO STOP AT 9:30 PM - TABLE REMOVED BY 10:30 P.M.

Add Activity

Action	Notes	DISP	ASSIGNED	DATE1	DATE2	DATE3	Done By
Application Received						6/22/2007	TCOZ
Zoning Sign-off		APP		6/22/2007		6/22/2007	TCOZ
Use Permit Referral -Building					6/22/2007		
Building Inspection Referral	9/21/2007 15:24:21 JCOL - activity updated through activity USEK404 from case USE2007-02649.	DONE			6/23/2007	9/21/2007	JCOL
Application Received		DONE				6/22/2007	TCOZ
Minor Privilege	MINOR PRIVILEGE PERMIT T111695	APP	MPRV	6/22/2007		9/21/2007	MPRV
Filing-Draft Only		DONE				6/22/2007	TKAH
Occupancy Certification		APP	THAR	9/21/2007	9/21/2007	9/21/2007	JCOL
Set Finaled Date			ASHA			9/21/2007	JCOL
Change Status to RTI						9/21/2007	JCOL
Print Draft C of O		DONE				9/21/2007	BMCF
Print C of O		DONE				9/21/2007	

Certificate of Occupancy

THIS WRITTEN INSTRUMENT, WHEN PROPERLY VALIDATED, CONSTITUTES AUTHORITY FOR DOING OR RECEIVING THE THINGS INDICATED BY THE FEES OR CHARGES SHOWN IN THE APPROPRIATE SPACES BELOW ANY AND ALL THINGS TO BE DONE OR RECEIVED UNDER THIS WRITTEN INSTRUMENT SHALL BE DONE OR RECEIVED IN STRICT COMPLIANCE WITH THE APPLICATION HERETOFORE FILED IN THIS DEPARTMENT FOR THE AUTHORITY CONTAINED HEREIN, INCLUDING ANY AND ALL APPROVED DRAWINGS AND OTHER DATA OR INFORMATION ATTACHED THERETO, AND SUBJECT TO ANY AND ALL LAWS, ORDINANCES, RULES AND REGULATIONS IN EFFECT IN THE CITY OF BALTIMORE AND THE STATE OF MARYLAND. WARNING: IT IS UNLAWFUL TO WORK BETWEEN THE HOURS OF 7:00 PM AND 7:00 AM WITHIN 300 FEET OF A DWELLING.

WARNING: IT IS UNLAWFUL TO CONCEAL ANY WORK UNTIL INSPECTED AND APPROVED BY THIS DEPARTMENT.

WARD	SEC.	BLOCK	LOT	ISSUE DATE	DISTRICT
24	10	2019A	046	8/1/13	901

PROPERTY ADDRESS: 1401 E CLEMENT ST

OWNER: 1401 E. CLEMENT ST. LLC. ADDR: 1401 E. CLEMENT STREET BALTIMO

LESSEE: ADDR:

LAND USE CODES 5823 5810 0000 0000

CONTINUE TO USE AS A RESTAURANT/ TAVERN CHANGE OF OWNERSHIP

1001-000000-2600-159600-400560 PER. INSP	1001-000000-2600-158009-400480 MISC	1001-000000-2600-158009-400480 CH USE	1001-000000-2600-158301-400490 NEW BLDG	1001-000000-2600-158302-400490 ADDITIONS
		45.00		
1001-000000-2600-158302-400490 ALTERATIONS	1001-000000-2600-158304-400490 REPAIRS	1001-000000-2600-158304-400490 MISC CONST	1001-000000-2600-158600-400500 ELECT	1001-000000-2600-158901-400510 HYDRONIC/STEAM HEAT
1001-000000-2600-158902-400510 DISTRIB/EXH	1001-000000-2600-158902-400510 AIR COND	1001-000000-2600-158902-400510 DISP TANKS	1001-000000-2600-158905-400510 FIRE	1001-000000-2600-158906-400510 FUEL-BURNING EQUIPMENT
1001-000000-2600-159300-400530 ELEVATOR	1001-000000-2600-159000-400520 PLUMBING	1001-000000-2600-159000-400520 S & E CONTROL	1001-000000-5700-508801-401811 CHAP	1001-000000-1500-102800-400230 TAX
	0.00			3.00
1001-000000-2600-158306-400490 RAZING	1001-000000-2600-159400-400540 FILING FEE	1001-000000-2600-159400-400540 LOW VOLTAGE TELECOMMUNICATIONS	1001-000000-2600-158905-400510 PENALTY	TOTAL FEES
	50.00			98.00

THE AUTHORITY CONTAINED HEREIN MAY NOT BE VALIDLY EXERCISED UNTIL AND AFTER ALL OF THE FEES APPEARING HEREON HAVE BEEN PAID AND EVIDENCE THEREOF APPEARS IN THIS SPACE.



Michael Braverman
 MICHAEL BRAVERMAN
 BUILDING OFFICIAL

Please be advised that there is a presumption of lead-based paint in properties constructed prior to 1950. Protect workers and tenants by using the lead-safe work practices found in the Code of Maryland Regulations Section 26.02.07.

THE AUTHORITY CONTAINED HEREIN DOES NOT AUTHORIZE THE PERFORMANCE OF ANY WORK IN, ON, UNDER OR OVER ANY STREET, HIGHWAY, ALLEY, SIDEWALK OR ANY OTHER PUBLIC WAY, UNLESS PERMISSION TO DO SO HAS BEEN FIRST SECURED FROM THE PROPER AUTHORITY

January 4, 2018

Applicant(s): Christopher Brown, Ivelisse Contreras, and Andrea Warfel
511 South Central Beverage, LLC, T/a Hyatt Place Baltimore Inner Harbor
511 S. Central Avenue 21231

Class: "B (H-M)" Beer, Wine & Liquor License

Application to transfer ownership requesting live entertainment, outdoor table service, and delivery of alcoholic beverages via room service.

(a) Applicant(s) Information: (1) Christopher Brown was born in Manassas, VA in June of 1987. He lives in Baltimore, MD; (2) Ivelisse Contreras was born in Bayamon, PR in July of 1981. She lives in Beltsville, MD; and (3) Andrea Warfel was born in Annapolis, MD in December of 1986. She lives in Bowie, MD.

(b) Ownership Breakdown: (1) Christopher Brown (1%); (2) Ivelisse Contreras (1%); (3) Susan Cook (1%); and (4) 511 South Central Avenue, LLC (97%).

(c) Purchase Price of Business: There were no funds exchanged for the transfer of this license. 511 South Central, LLC had originally contracted with Interstate Management Company, LLC (current licensee) to run the alcoholic beverage service operations of the hotel. 511 South Central, LLC terminated its contract with Interstate Management Company, LLC and entered into agreement with 511 South Central Beverage, LLC to operate the establishment. Thus, the corporation is restructuring in order to change operations concerning the alcoholic beverages distribution at the location. Please note that 511 South Central, LLC owns 100% of 511 South Central Beverage, LLC and thus continues to maintain its interest in the liquor license.

(d) Qualified Voters: Patricia Laro-Okay, Martha Harvey, and Theodore Kitson-Okay are qualified Baltimore City voters.

(e) Zoning: Applicants have applied for a USE permit, for the continued use of the property as an 8 story Hyatt Place Hotel with 208 rooms and 2nd floor parking garage.

(f) Corporate Standing: 511 South Central Beverage, LLC is a MD LLC and as of 12/21/2017 is active and in good standing.

(g) Posting Report: The location was posted on 11/15/2017, and checked on 11/27/2017. This meets the 10-day rule. There are 14 licensed liquor establishments in the 4x4 area: "D" BW-1; "B" BWL-9; and "BD7" BWL-4.

(h) Timeline: Last inspection by BLLC was performed 11/20/2017. At that time, the establishment was open and operating.

(i) Letters of Support/Opposition: At this time the Board has no letters of support or opposition.

In considering this request, under the provisions of Alcohol Beverage Article 4-210(A) the Board must consider the following factors: 1. The public need and desire for the license; 2. The number and location of existing license holders; 3. The potential effect on existing license holders of the license for which application is made; 4. The potential commonality or uniqueness of the services and products to be offered by the business of the applicant; 5. The impact of the license for which application is made on the health, safety, and welfare of the community, including issues relating to crime, traffic conditions, parking, or convenience; and 6. Any other factor that the local licensing Board considers necessary.

Board's Decision:

REVISED

Application for Alcoholic Beverages License Board of Liquor License Commissioners for Baltimore City

NEW/TRANSFER/EXPANSION/AMENDMENT(S) APPLICATION FEE - \$600.00

***Place cursor on the field to enter text Do Not tab.

INDICATE TYPE OF LICENSE APPLICATION: TRANSFER [X] NEW [] EXPANSION OF PREMISES [] AMENDMENT(S) []
EXPLANATION OF REQUEST: Transfer of License CLASS TYPE: B.BWL #
IF NEW LICENSE REQUEST, THEN ADDRESS OF PROPOSED LOCATION: N/A
IF TRANSFER OF OWNERSHIP ONLY, THEN ADDRESS OF CURRENT LICENSE: 511 South Central Avenue, Baltimore, Maryland 21202
IF TRANSFER OF OWNERSHIP AND LOCATION, THEN CURRENT ADDRESS OF LICENSED LOCATION: N/A
IF TRANSFER OF OWNERSHIP AND LOCATION, THEN ADDRESS OF PROPOSED RELOCATION: N/A
CORPORATE/LLC/LLP/PARTNERSHIP NAME: 511 South Central Beverage, LLC TRADE NAME: Hyatt Place Baltimore Inner Harbor
BUSINESS PHONE NUMBER: 410-558-1840 BUSINESS EMAIL ADDRESS: Karen.Stringer@SageHospitality.com
ATTORNEY FOR THE APPLICANT: Linda C. Carter, Meyers, Rodbell & Rosenbaum ADDRESS: 6601 Kenilworth Ave., Ste 400, Riverdale, MD 20737 PHONE: 301-699-5800

Part of Premises Used (Note: Floors and Areas for Storage): All public areas, hotel rooms, conference / meeting rooms, and storage areas

Live Entertainment provided? [X] Yes [] No What Kind (Ex. D.J. Band, Etc.): Private events in ballrooms

Outdoor Table Service Provided? [X] Yes [] No Off Premise Catering of Food and Alcohol? [] Yes [] No Catering Application filed with BLLC? [] Yes [X] No

** Delivery of alcohol? [X] Yes [] No Zoning Receipt or Current Certificate of Occupancy Permit attached to Application? [] Yes [X] No

Please note that as per Alc. Bev. Art. § 12-1407(A)(2), an application for the issuance or transfer, is not complete unless the applicant has obtained approval and/or verification from the Baltimore Municipal Zoning Administration (BMZA)

1. Applicant A

Christopher G. Brown 410-485-4339 cgbruns@aol.com
(5112 Frankford Avenue) (Baltimore MD 20216) (25 years)
(Residence) Street City State Zip Code (period of residency in Baltimore City)
06/1987 Male Manassas, VA
(Month/Year of Birth) (Sex: Male or Female) (Place of Birth)
Check: [X] Yes [] No Have you been a resident and taxpayer of the City of Baltimore for 2 years preceding this application?
[] Yes [] No Are you a registered voter in the City of Baltimore?

2. Applicant B

Ivelisse Contreras 352-978-4304 icontreras@mrlaw.net
(11914 Twinlakes Drive Apt 14) (Beltsville MD 20705) (N/A)
(Residence) Street City State Zip Code (period of residency in Baltimore City)
04/1987 Female Bayamon, PR, USA
(Month/Year of Birth) (Sex: Male or Female) (Place of Birth)
Check: [] Yes [X] No Have you been a resident and taxpayer of the City of Baltimore for 2 years preceding this application?
[X] Yes [X] No Are you a registered voter in the City of Baltimore?

3. Applicant C

Andrea G. Warfel 301-312-7382 awarel@mrlaw.net
(14020 Lancaster Lane) (Bowie MD 20715) (N/A)
(Residence) Street City State Zip Code (period of residency in Baltimore City)
12/1986 Female Annapolis, MD
(Month/Year of Birth) (Sex: Male or Female) (Place of Birth)
Check: [] Yes [X] No Have you been a resident and taxpayer of the City of Baltimore for 2 years preceding this application?
[] Yes [X] No Are you a registered voter in the City of Baltimore?

** in the form of room service
Revised January 2017

1. Has the applicant(s) been adjudged guilty of a felony in the State of Maryland or any other? Yes No - If yes, indicate applicant and explain.

Applicant A B C

NONE of the applicants have been adjudged guilty of a felony.

2. Has the applicant(s) been adjudged guilty of violating the laws governing the sale of any alcoholic beverage or for gambling in any State, including Maryland? Yes No - If yes, mark applicant and provide an explanation in adjacent space provided.

Applicant A B C

NONE of the applicants have been adjudged guilty of violating liquor or gambling laws

3. State whether the applicant(s) has ever been adjudged guilty of any offense against the laws of the State of Maryland, any other State within the United States, or against the United States (Federal Crime)? Yes No - If yes, mark applicant and explain.

Applicant A B C

NONE of the applicants have been adjudged guilty of any offense against the laws of Maryland or any other state or United States.

4. Has the applicant(s) ever had a license for the sale of alcoholic beverages in the State of Maryland? Yes No If yes, mark applicant and explain.

Applicant A B C

Applicants A, B & C have never been on an alcoholic beverage license.

5. Has the applicant(s) ever had a liquor license suspended or revoked? Yes No If yes, mark applicant and explain.

Applicant A B C

NONE of the applicants have ever had a license suspended or revoked.

6. Does the applicant(s) have a financial interest in any other alcoholic beverage business or business for which an alcoholic beverage license has been applied for, granted, and issued? Yes No If yes, mark applicant and explain.

Applicant A B C

Applicant A has 1/3% Class B Interest, Applicant B has 1/3 % Class B interest, Applicant C has 1/3 % Class B interest The remaining 100% interest is owned by 511 South Central Avenue, LLC

7. Do the spouses or children of any of the applicant(s) have a financial interest in any other alcoholic beverages license or business in Baltimore City or any other jurisdiction in the State of Maryland? Yes No If yes, mark applicant and explain.

Applicant A B C

None of the applicants have any children or spouses on an alcoholic.

8. Are you financially interested in any other alcoholic beverages license applied, granted or issued? Yes No If yes, please explain.

Applicant A B C

9. Is the licensed premise currently open and operating? Yes No If no, then please explain when the establishment ceased operations.

10. Do any of the applicant(s) - personally or through an entity - have any indebtedness or other financial obligations to any manufacturer, brewer, distiller, or wholesaler at the time of making this application? Yes No If yes, please explain. If yes, please provide information as to the applicant(s) indebted - personally or through an entity - the amount of the indebtedness, and the name of the manufacturer, brewer, distiller, or wholesaler?

Applicant A B C

NONE of the applicants have any indebtedness or financial obligation to any manufacturer, etc.

II. Please list the following information for the Manager of the establishment to be licensed:

Name	Address	Phone	Email

Applicants Applying as Business Entities - (Give name(s) and addresses - in Corporation list all officers (attach list if necessary) or in Limited Liability Company/Partnerships list all authorized persons.) *Please note that all licensees MUST have a FINANCIAL INTEREST in the license applied for as per Alc. Bev. Art. § 4-109 (a)(II). If necessary, please attach a list of the names and address of all outstanding stock holders who at the time of application own more than 5% of the outstanding stock of the corporation and the articles of incorporation, partnership agreement or articles of organization.*

- 1) NAME: Christopher G. Brown ADDRESS: 5112 Frankford Avenue, Baltimore, MD 21206 TITLE: Auth. Per. %OF STOCK HELD: 1/3 Class B
- 2) NAME: Ivelisse Contreras ADDRESS: 11914 Twinlakes Dr, Apt 14, Beltsville, MD 20705 TITLE: Auth. Per. %OF STOCK HELD: 1/3 Class B
- 3) NAME: Susan S. Cook ADDRESS: 11402 Hennessey Dr., Beltsville, MD 20705 TITLE: Auth. Per. %OF STOCK HELD: 1/3 Class B
- 4) NAME: 511 South Central Avenue, LLC ADDRESS: 1575 Welton Street, Suite 300, Denver, CO 80202 TITLE: Mange. Mbr %OF STOCK HELD: 100 Class A

**Extract from Law: If any affidavit or oath required under the provisions of this Act shall contain any false statements, the offender shall be deemed guilty of perjury. And upon indictment and conviction thereof, shall be subject to penalties provided by Law for that crime.*

CERTIFICATE OF APPLICANTS: At least one applicant whose signature appears below certifies that he/she has been a resident and taxpayer of Baltimore City, Maryland for at least two years preceding the filing of this application. Each of said applicants hereby certifies further that if the license applied for is granted, he/she will conform to all State and County laws and regulations relating to the sale of alcoholic beverages, as well as to the rules and regulations of the Board of License Commissioners for Baltimore City, and hereby grants permission to the State Comptroller, his duly authorized deputies, inspectors and clerks, The Board of License Commissioners for Baltimore City, its duly authorized agents and employees, and any peace officer of Baltimore City or the State of Maryland to inspect and search at any and all hours, without warrant, the premises and any and all parts thereof upon and in which said business is to be conducted.

Christopher G. Brown
Signature of Applicant A Christopher G. Brown

I hereby certify that on the 20th day of July, 2017, before me, the subscriber, a notary public of the State of Maryland in and for Prince George's, personally appeared Christopher G. Brown the applicant(s) named in this renewal application made oath in due form of law that the matter and facts contained in said application are true and correct. As witness, my hand and notarial seal.

Signature: Jasmine Delgado-Bowes [Notary Seal] My Commission expires 1/12/2019

Printed Name: Jasmine Delgado-Bowes

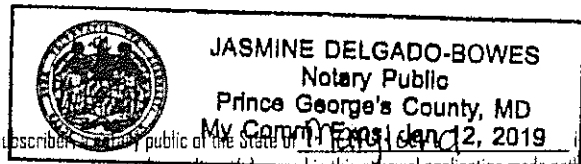

Ivelisse Contreras
Signature of Applicant B

I hereby certify that on the 7 day of July, 2017, before me, the subscriber, a notary public of the State of Maryland in and for Prince George's County, personally appeared Ivelisse Contreras the applicant(s) named in this renewal application made oath in due form of law that the matter and facts contained in said application are true and correct. As witness, my hand and notarial seal.

Signature: Lizkaren Lam [Notary Seal] My Commission expires April 24, 2021

Printed Name: Lizkaren Lam



Susan S. Cook
Signature of Applicant C

I hereby certify that on the 7 day of July, 2017, before me, the subscriber, a notary public of the State of Maryland in and for Prince George's County, personally appeared Susan S. Cook the applicant(s) named in this renewal application made oath in due form of law that the matter and facts contained in said application are true and correct. As witness, my hand and notarial seal.

Signature: Lizkaren Lam [Notary Seal] My Commission expires April 24, 2021

Printed Name: Lizkaren Lam



11. Please list the following information for the Manager of the establishment to be licensed:

Name	Address	Phone	Email

Applicants Applying as Business Entities - (Give name(s) and addresses - in Corporation list all officers (attach list if necessary) or in Limited Liability Company/Partnerships list all authorized persons.) *Please note that all licensees MUST have a FINANCIAL INTEREST in the license applied for as per Alc. Bev. Art. § 4-109 (a)(II). If necessary, please attach a list of the names and address of all outstanding stock holders who at the time of application own more than 5% of the outstanding stock of the corporation and the articles of incorporation, partnership agreement or articles of organization.*

- 1) NAME: Christopher G. Brown ADDRESS: 5112 Frankford Avenue, Baltimore, MD 21206 TITLE: Auth. Per. %OF STOCK HELD: 1
- 2) NAME: Ivelisse Contreras ADDRESS: 11914 Twinlakes Dr, Apt 14, Beltsville, MD 20705 TITLE: Auth. Per. %OF STOCK HELD: 1
- 3) NAME: Andrea G. Warfel ADDRESS: 14020 Lancaster Lane TITLE: Auth. Per. %OF STOCK HELD: 1
- 4) NAME: 511 South Central Avenue, LLC ADDRESS: 1575 Welton Street, Suite 300, Denver, CO 80202 TITLE: Mange. Mbr %OF STOCK HELD: 97

**Extract from Law: If any affidavit or oath required under the provisions of this Act shall contain any false statements, the offender shall be deemed guilty of perjury. And upon indictment and conviction thereof, shall be subject to penalties provided by Law for that crime.*

CERTIFICATE OF APPLICANTS: At least one applicant whose signature appears below certifies that he/she has been a resident and taxpayer of Baltimore City, Maryland for at least two years preceding the filing of this application. Each of said applicants hereby certifies further that if the license applied for is granted, he/she will conform to all State and County laws and regulations relating to the sale of alcoholic beverages, as well as to the rules and regulations of the Board of License Commissioners for Baltimore City, and hereby grants permission to the State Comptroller, his duly authorized deputies, inspectors and clerks, The Board of License Commissioners for Baltimore City, its duly authorized agents and employees, and any peace officer of Baltimore City or the State of Maryland to inspect and search at any and all hours, without warrant, the premises and any and all parts thereof upon and in which said business is to be conducted.

Christopher G. Brown
Signature of Applicant A

I hereby certify that on the _____ day of _____, 20____, before me, the subscriber, a notary public of the State of _____ in and for _____, personally appeared _____ the applicant(s) named in this renewal application made oath in due form of law that the matter and facts contained in said application are true and correct. As witness, my hand and notarial seal.

Signature: _____ [Notary Seal] My Commission expires _____

Printed Name: _____

Ivelisse Contreras
Signature of Applicant B

I hereby certify that on the _____ day of _____, 20____, before me, the subscriber, a notary public of the State of _____ in and for _____, personally appeared _____ the applicant(s) named in this renewal application made oath in due form of law that the matter and facts contained in said application are true and correct. As witness, my hand and notarial seal.

Signature: _____ [Notary Seal] My Commission expires _____

Printed Name: _____

Andrea G. Warfel
Signature of Applicant C

I hereby certify that on the 25 day of September, 2017, before me, the subscriber, a notary public of the State of Maryland in and for Prince Georges Co, personally appeared Andrea G. Warfel the applicant(s) named in this renewal application made oath in due form of law that the matter and facts contained in said application are true and correct. As witness, my hand and notarial seal.

Signature: Susan S Cook [Notary Seal] My Commission expires 9/20/2021

Printed Name: Susan S Cook



Susan S. Cook
NOTARY PUBLIC
Prince George's County
State of Maryland
My Commission Expires
September 20, 2021

Name and Address of the owners of the premise/landlord: 511 South Central Avenue, LLC 1575 Welton Street, Suite 300, Denver, CO 80202 Phone Number: 303-595-7284

STATEMENT OF OWNER OF PREMISES REQUIRED IN CONNECTION WITH ALCOHOLIC BEVERAGES LAW OF MARYLAND

(I, WE) 511 South Central Avenue, LLC HEREBY CERTIFY, That (I am, we are) the owner(s) of the property located at 511 South Central Avenue, Baltimore, MD, Baltimore, City with a Zip Code of 21202, which is named in the present application made to Board of Liquor License Commissioners of Baltimore City under the Alcoholic Beverage Laws of Maryland and assent to the granting of the license applied for, and hereby authorize the State Comptroller, his duly authorized deputies, inspectors and clerks, the Board of Liquor License Commissioners of Baltimore City, its duly authorized agents and employees, and any peace officer of the City of Baltimore and State of Maryland, to inspect and search, without warrant, the premises upon which the business is to be conducted, and any and all parts of the building in which said business is to be conducted, at any and all hours.

I hereby certify that on the 21st day of July, 2017 before me, the subscriber, a notary public of the State of Colorado in and for Denver, personally appeared C Harris White the applicant(s) named in this renewal application made oath in due form of law that the matter and facts contained in said application are true and correct.

As witness, my hand and notarial seal, South 511 Central Avenue, LLC by Sage Baltimore Managing Member, LLC is manager Harris White, Authorized Person

Signature: [Signature]

[Notary Seal] My Commission Expires 3/27/18
DEBRA S. KEESLING
 NOTARY PUBLIC
 STATE OF COLORADO
 NOTARY ID 20144013534
 My Commission Expires Mar. 27, 2018

Printed Name: Harris White

The following certificates must be signed by at least 3 persons.

We, the undersigned citizens, real estate owners and registered voters in the City of Baltimore in which the business covered by the present application is to be conducted, certify that the qualifying applicant(s) is/are personally known to us and has been a resident or a taxpayer of Baltimore City and a resident of the State of Maryland for 2 years preceding this application.

Names	Address	Signature	DOB (Month/Year)	Length of time Acquainted with the Applicant(s)
Patricia Laro	4403 White Avenue Baltimore, MD 21206	[Signature]	05/1954	10 years
Bill Welsh	5110 FRANKFORD AVE BALTO., MD 21206	[Signature]	11/1950	30 YEARS
Theodore Kitson	5200 FRANKFORD AVE	[Signature]	11/8/48	18 YRS.

Board of Liquor License Commissioners for the City of Baltimore,
 231 East Baltimore Street, 6th Floor, Baltimore, Maryland 21202
 Phone: 410-396-4377 Fax: 410-396-4382

Board of Liquor License Commissioners
 Please note that this is a public document and upon request will be provided to the general members of the public.

2017 JUL 31 PM 4:34

RECEIVED 4

Name and Address of the owners of the premise/landlord: 511 South Central Avenue, LLC 1575 Walton Street, Suite 303, Denver, CO 80202 Phone Number: 303-595-7284

STATEMENT OF OWNER OF PREMISES REQUIRED IN CONNECTION WITH ALCOHOLIC BEVERAGES LAW OF MARYLAND

(I, WE) 511 South Central Avenue, LLC HEREBY CERTIFY, That (I am, we are) the owner(s) of the property located at 511 South Central Avenue, Baltimore, MD, Baltimore, City with a Zip Code of 21202, which is named in the present application made to Board of Liquor License Commissioners of Baltimore City under the Alcoholic Beverage Laws of Maryland and assent to the granting of the license applied for, and hereby authorize the State Comptroller, his duly authorized deputies, inspectors and clerks, the Board of Liquor License Commissioners of Baltimore City, its duly authorized agents and employees, and any peace officer of the City of Baltimore and State of Maryland, to inspect and search, without warrant, the premises upon which the business is to be conducted, and any and all parts of the building in which said business is to be conducted, at any and all hours.

I hereby certify that on the _____ day of _____, 20____, before me, the subscriber, a notary public of the State of _____, in and for _____, personally appeared _____ the applicant(s) named in this renewal application made oath in due form of law that the matter and facts contained in said application are true and correct.

As witness, my hand and notarial seal, 511 Central Avenue, LLC by Sage Baltimore Managing Member, LLC is manager Harris White, Authorized Person

Signature: _____ [Notary Seal] My Commission expires _____

Printed Name: Harris White

The following certificates must be signed by at least 3 persons. We, the undersigned citizens, real estate owners and registered voters in the City of Baltimore in which the business covered by the present application is to be conducted, certify that the qualifying applicant(s) is/are personally known to us and has been a resident or a taxpayer of Baltimore City and a resident of the State of Maryland for 2 years preceding this application.

Names	Address	Signature	DOB (Month/Year)	Length of time Acquainted with the Applicant(s)
Patricia Laro	4403 White Avenue Baltimore, MD 21206	Patricia Laro	05/1954	10 years
Bill Welsh	5110 FRANKFORD AVE BALTO., MD 21206	Bill Welsh	11/1950	30 years
Theodore Kitson	5200 FRANKFORD AVE 3589	Theodore Kitson	11/8/42	18 YRS.
Martha Harvey	Johnson Dr.	Martha Harvey	1/25/60	30 yrs.
Patricia Andon	3514 Chestnut Hill	Patricia Andon	02/06/65	15 yrs

Board of Liquor License Commissioners for the City of Baltimore,
231 East Baltimore Street, 6th Floor, Baltimore, Maryland 21202
Phone: 410-396-4377 Fax: 410-396-4382

Please note that this is a public document and upon request will be provided to the general members of the public.

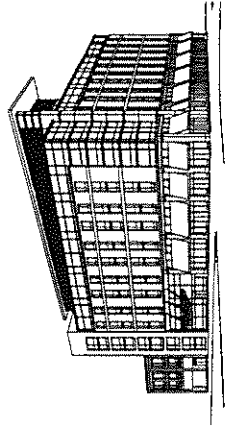

UNIVERSITY HOSPITAL REVIEW
DALLAS/IRVING EAST TOWER PLACE
AT
DALLAS, TEXAS 75241

COOPER COLLEGE

DATE: 11/23/11

© 2011 Cooper College, Inc. All Rights Reserved. No part of this publication may be reproduced without the prior written permission of Cooper College, Inc.



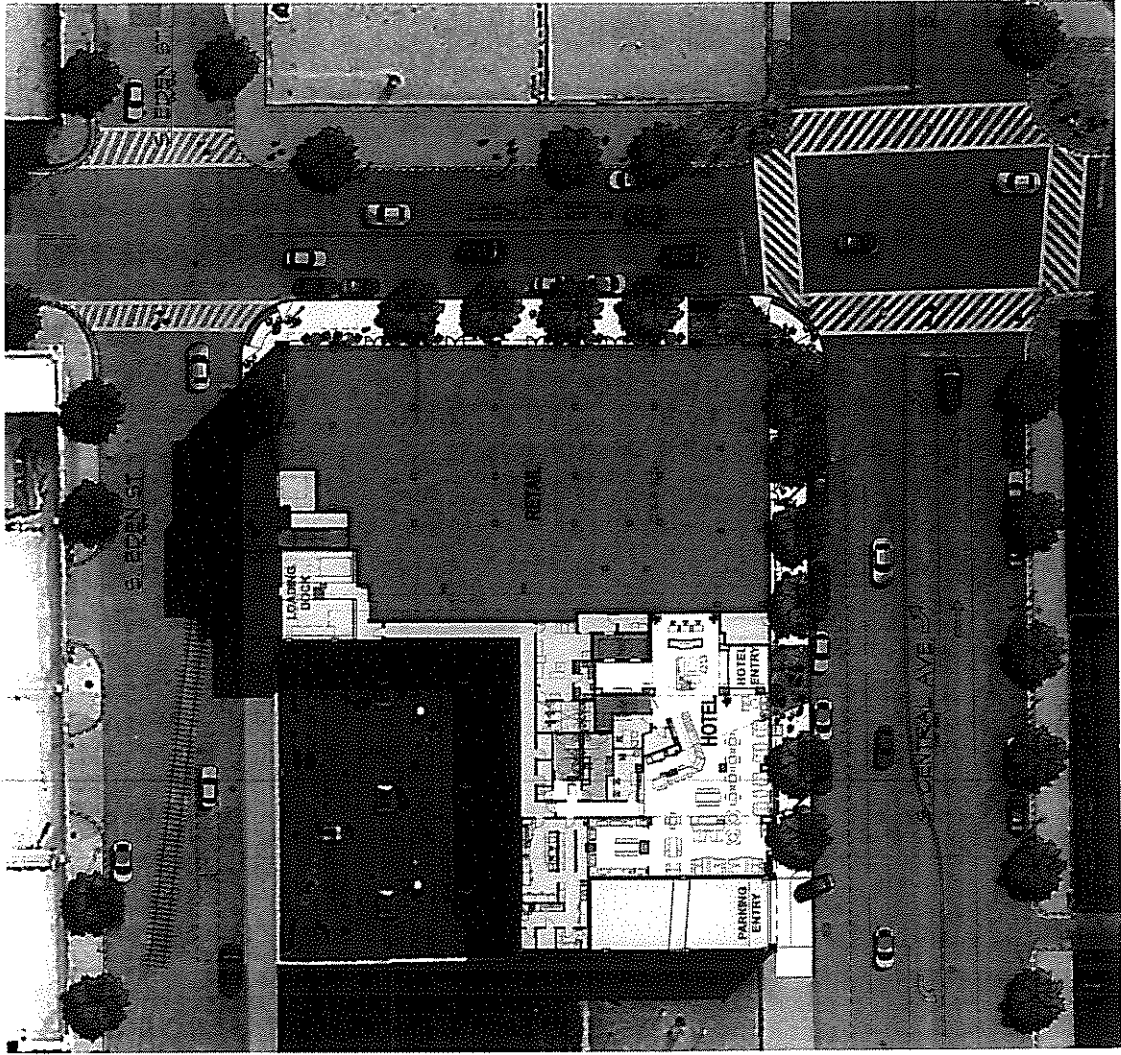

SITE PLAN
 HEALTHCARE LABORER EAST UNIT PLACE
 11111 South Loop West
 Houston, TX 77034



11/15/2011 10:00 AM
 11/15/2011 10:00 AM
 11/15/2011 10:00 AM
 11/15/2011 10:00 AM

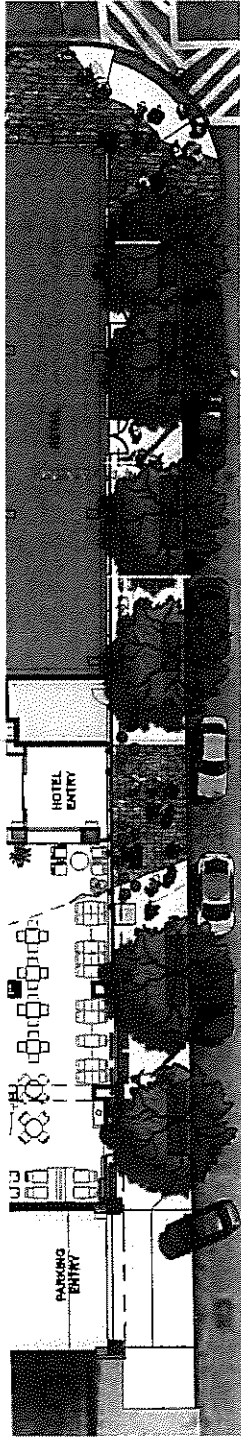

SOUTH CENTRAL AVENUE



FLEET STREET

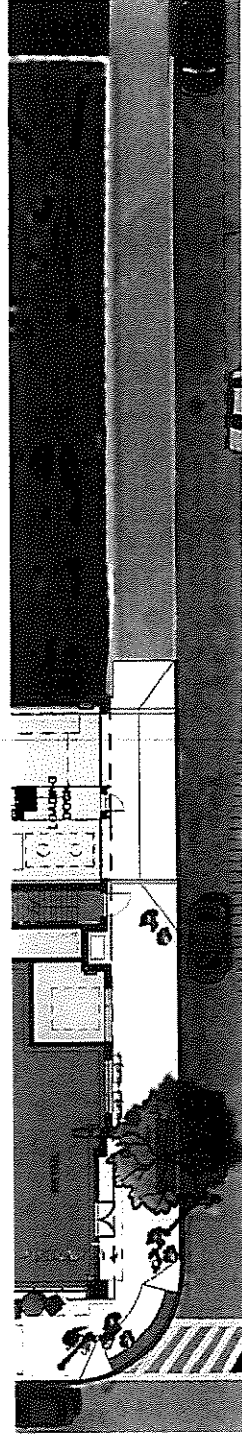

SOUTH EDEN STREET

ENLARGED STREETSCAPE PLANS
 BALTIMORE HARBOR EAST PLANT PLATE
 (1)
 November 2017/17

COOPER CLARK

SECOND FLOOR PLAN (PENDING LEVEL)
DATE: 10/15/2010
PROJECT: 10/15/2010

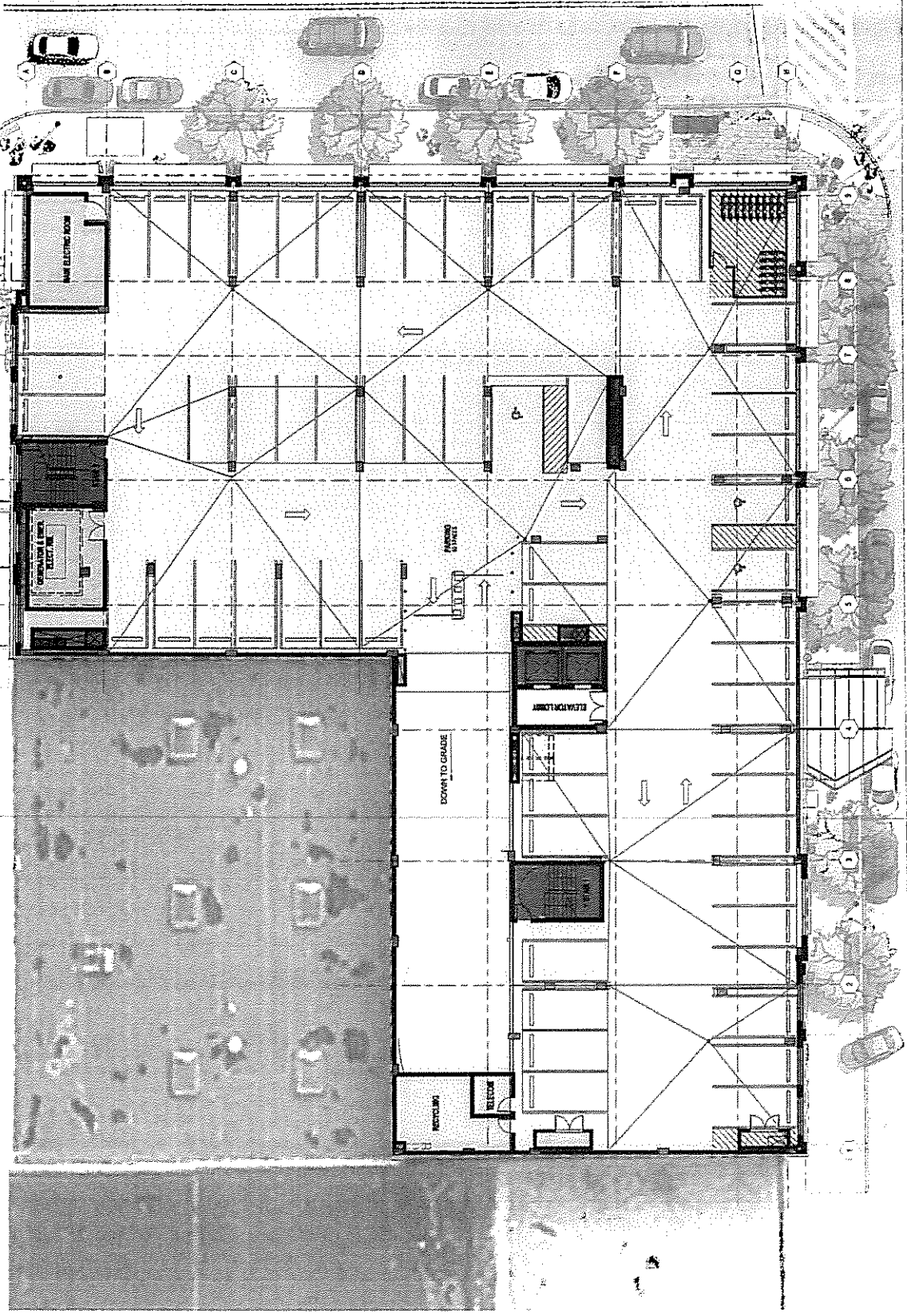

DATE: 10/15/2010
PROJECT: 10/15/2010
DRAWN BY: [Name]
CHECKED BY: [Name]

THIRD FLOOR PLAN (PARTIAL) LEVEL
301 EAST WILSON PARKWAY EAST WILSON PLACE
ANNAPOLIS, MD 21403

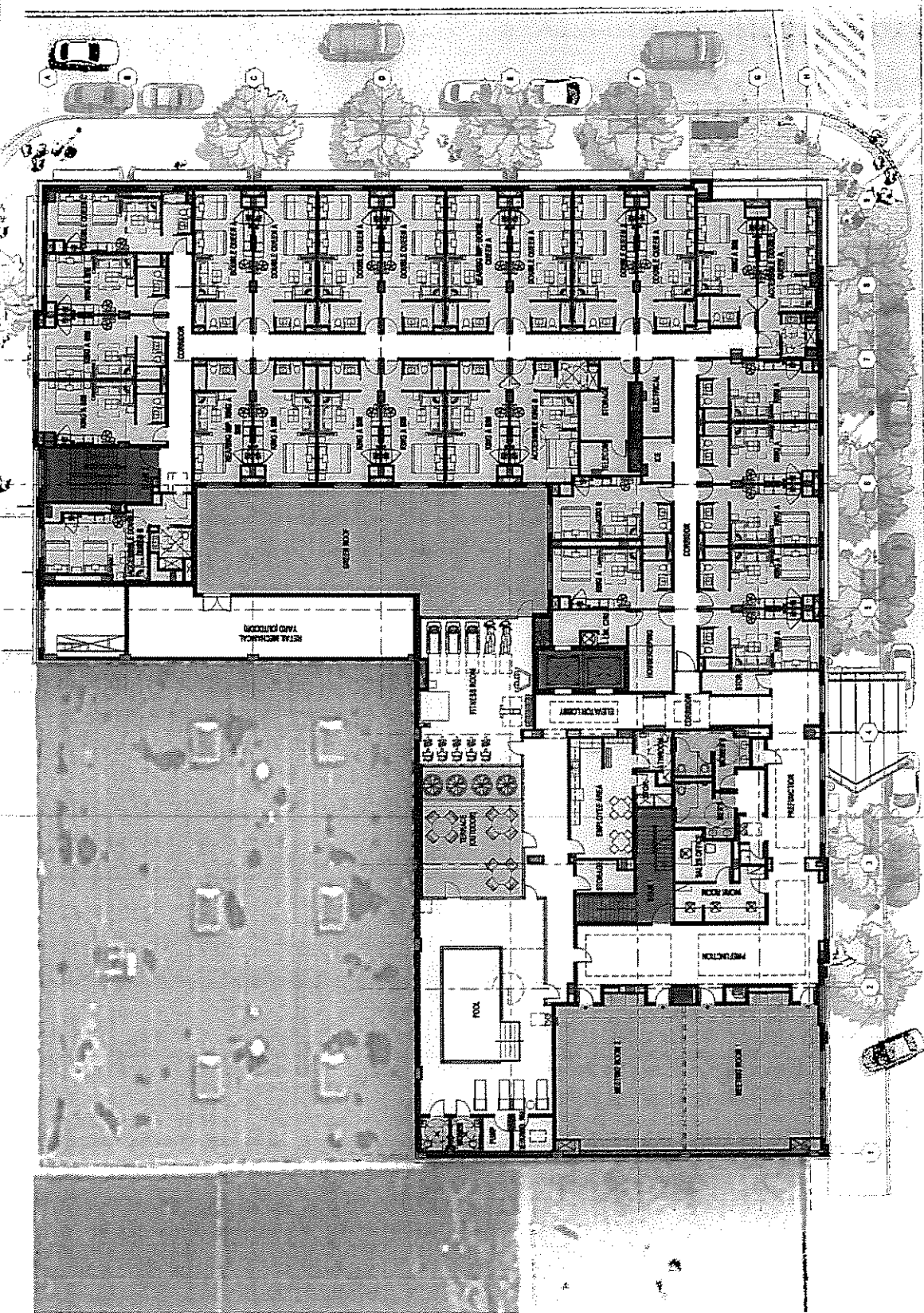

NOT TO SCALE. SEE ARCHITECTURAL RECORDS FOR DETAILS AND NOTES.

DATE: 10/15/2014
PROJECT: 10/15/2014

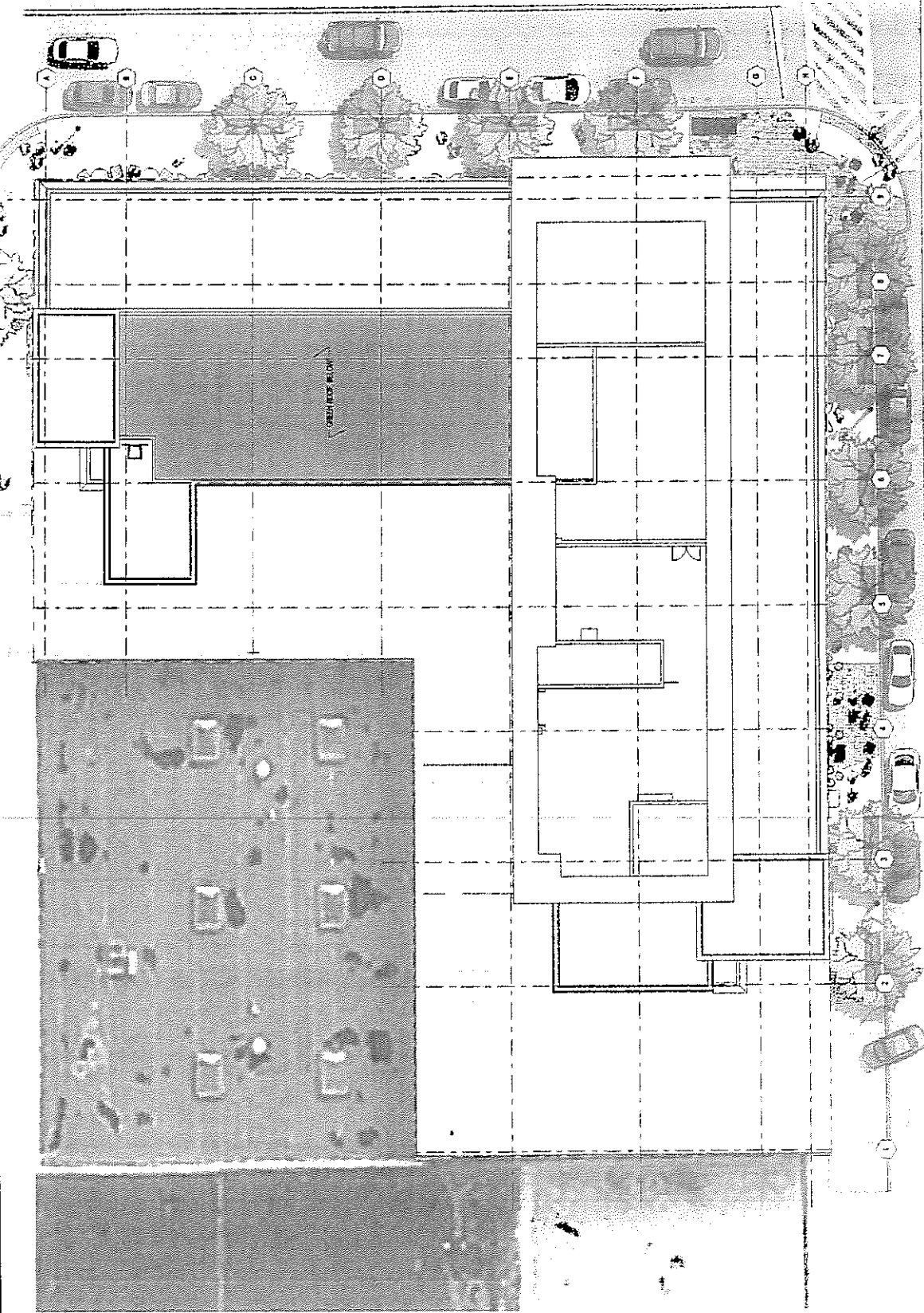

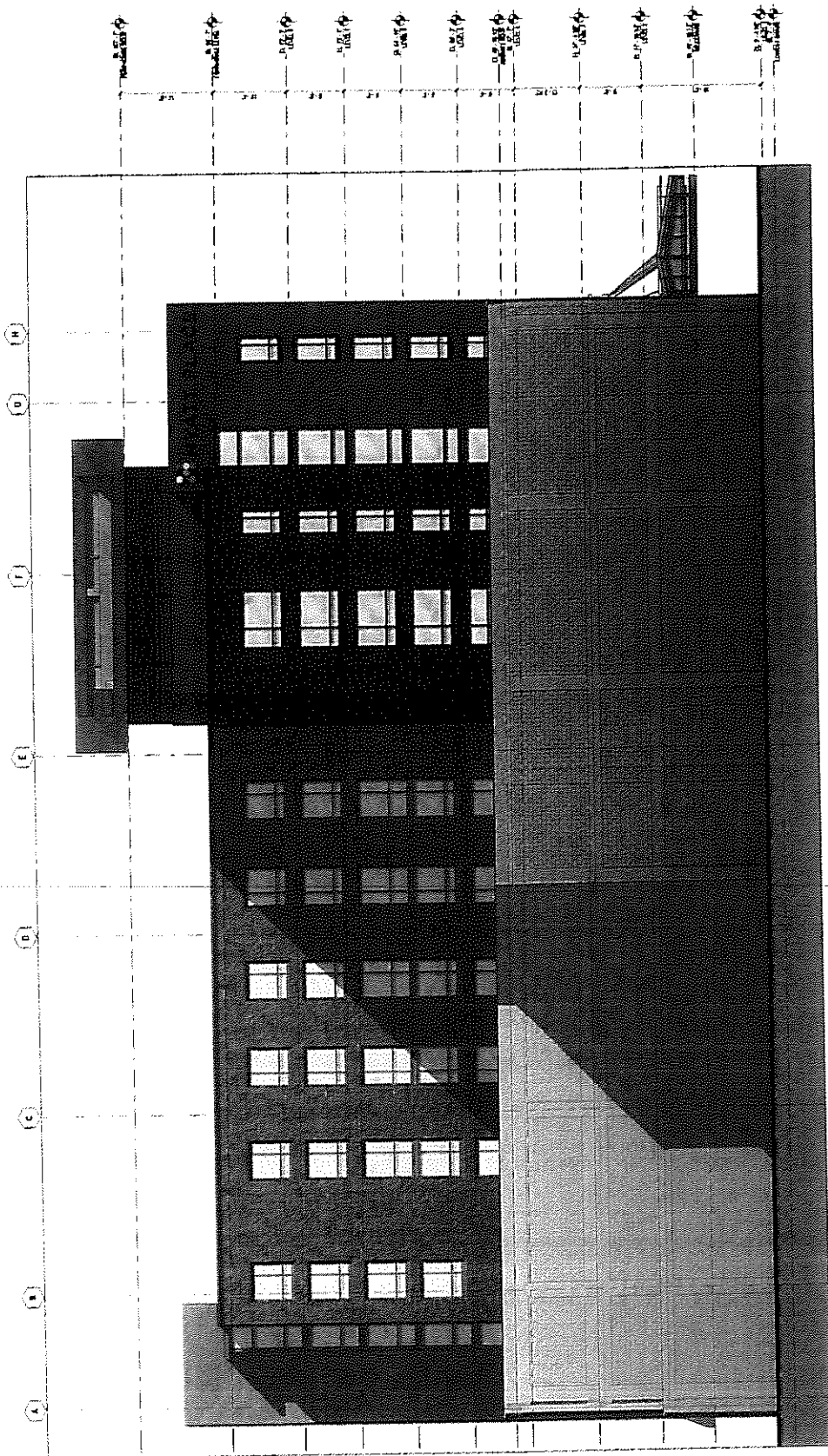

NORTH ELEVATION
 BALTIMORE HARBOUR EAST TOWER PLACE
 BALTIMORE, MARYLAND

COOPER CARNEY

10/20/14 30/20/14 10/1/17 01/21/17
 © 2014 CooperCarney, Inc. All Rights Reserved. No part of this document may be reproduced without the written permission of CooperCarney, Inc.



WEST ELEVATION - NORTH CENTRAL AVENUE
 BALTIMORE / ANSON EAST HAVAT PLACE
 117 East Central Avenue
 Baltimore, MD 21202

76
 COOPER CARRY

DATE: 08/21/14
 SCALE: 1/8" = 1'-0"

117 East Central Avenue, Baltimore, MD 21202

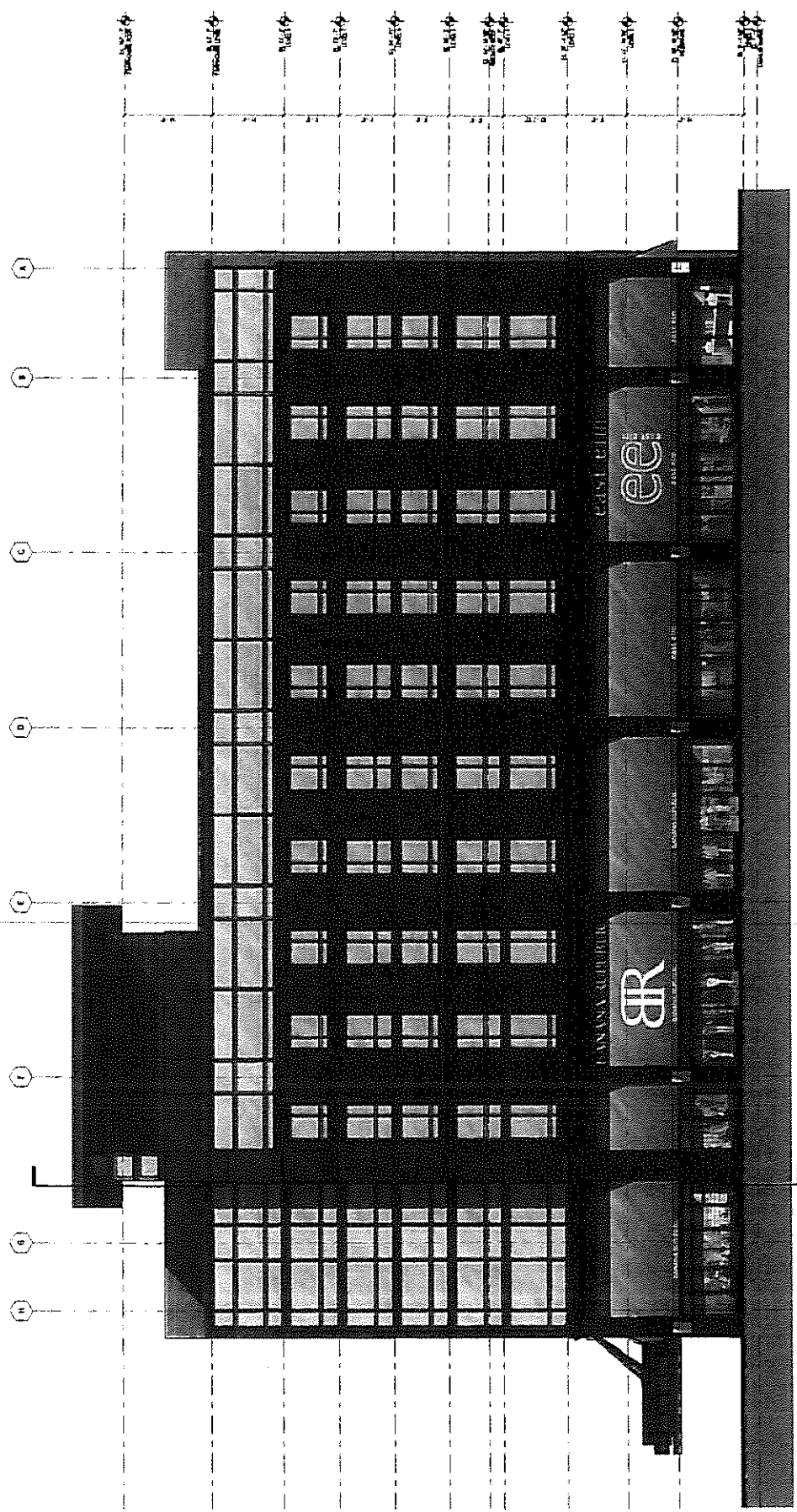

SOUTH ELEVATION - PLETT STREET
 111 PLETT STREET
 BALTIMORE, MARYLAND 21202



 COOPER CARRY

11/11/11 11:11 AM 11/11/11

© 2011 Cooper Carry, Inc. All rights reserved.

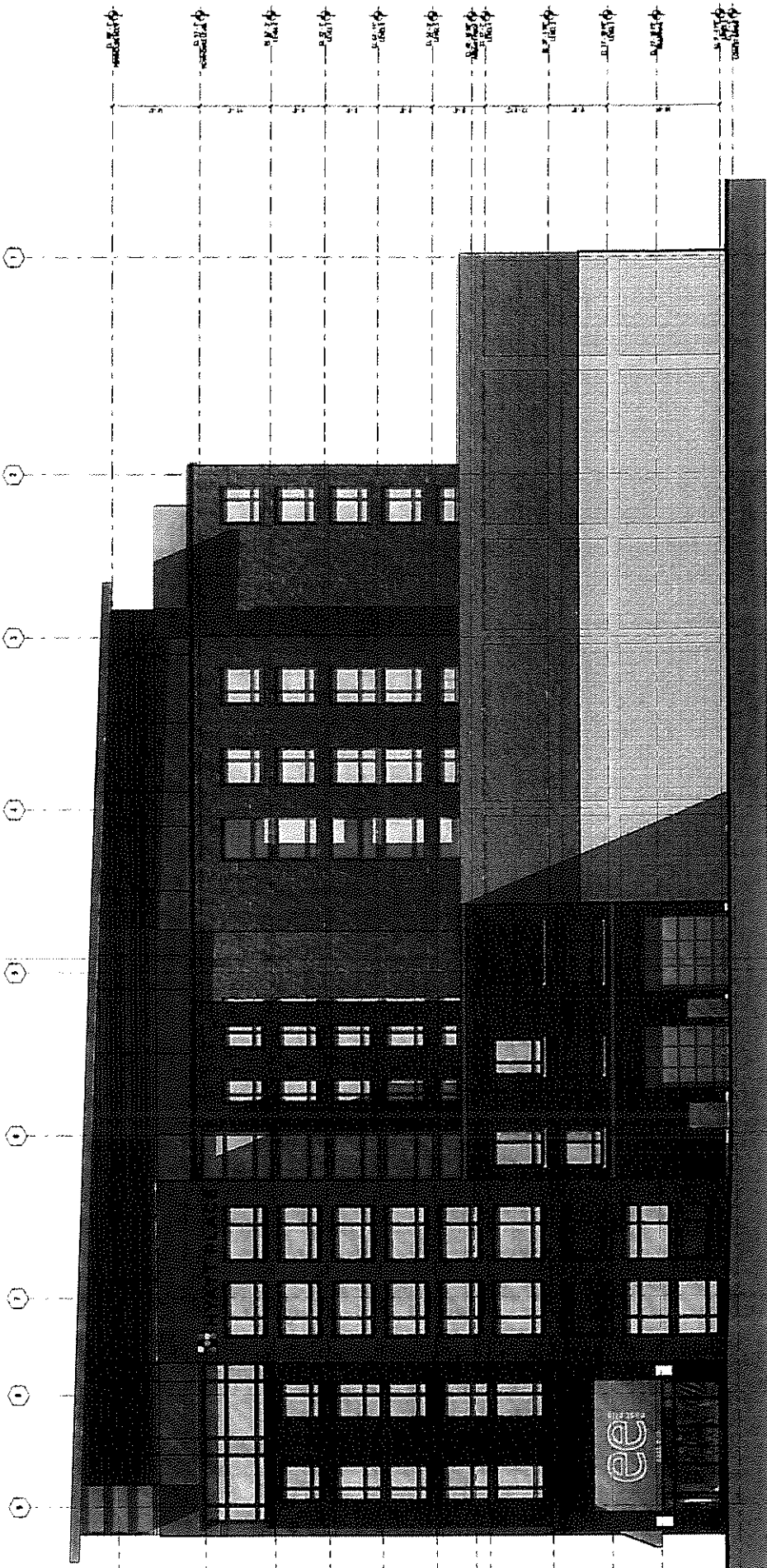

EAST OGDEN - SOUTH OGDEN STREET
 PAULISBURG LARKIN EAST HAVAT PLACE
 777 East Ogdren Street
 OGDEN, UTAH 84242

COVER CARLY

DATE: 11/11/11
 DRAWN BY: [illegible]
 CHECKED BY: [illegible]

PROJECT: [illegible]
 CLIENT: [illegible]
 ARCHITECT: [illegible]

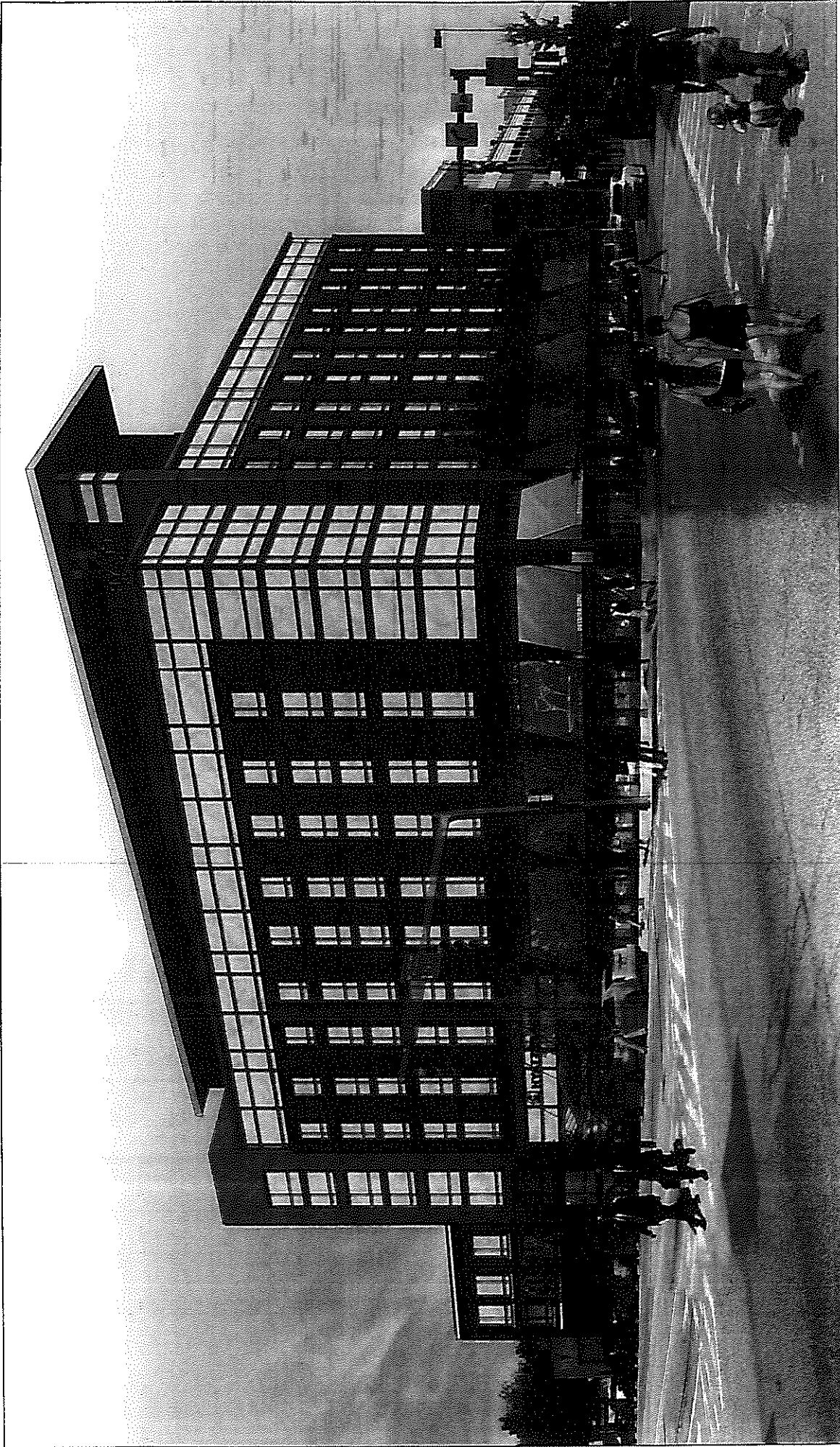

FLOOR 11 & SOUTH CENTRAL AVE. - PERSPECTIVE
BULL HORN BARRING EAST FRONT PLACE
100 East 10th Street
Austin, TX 78701

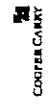

Scale: 1/8" = 1'-0"
Date: 08/20/11
Project: 11-000000

© 2011 CooperCarney, Inc. All rights reserved. No part of this document may be reproduced without the written consent of CooperCarney, Inc.

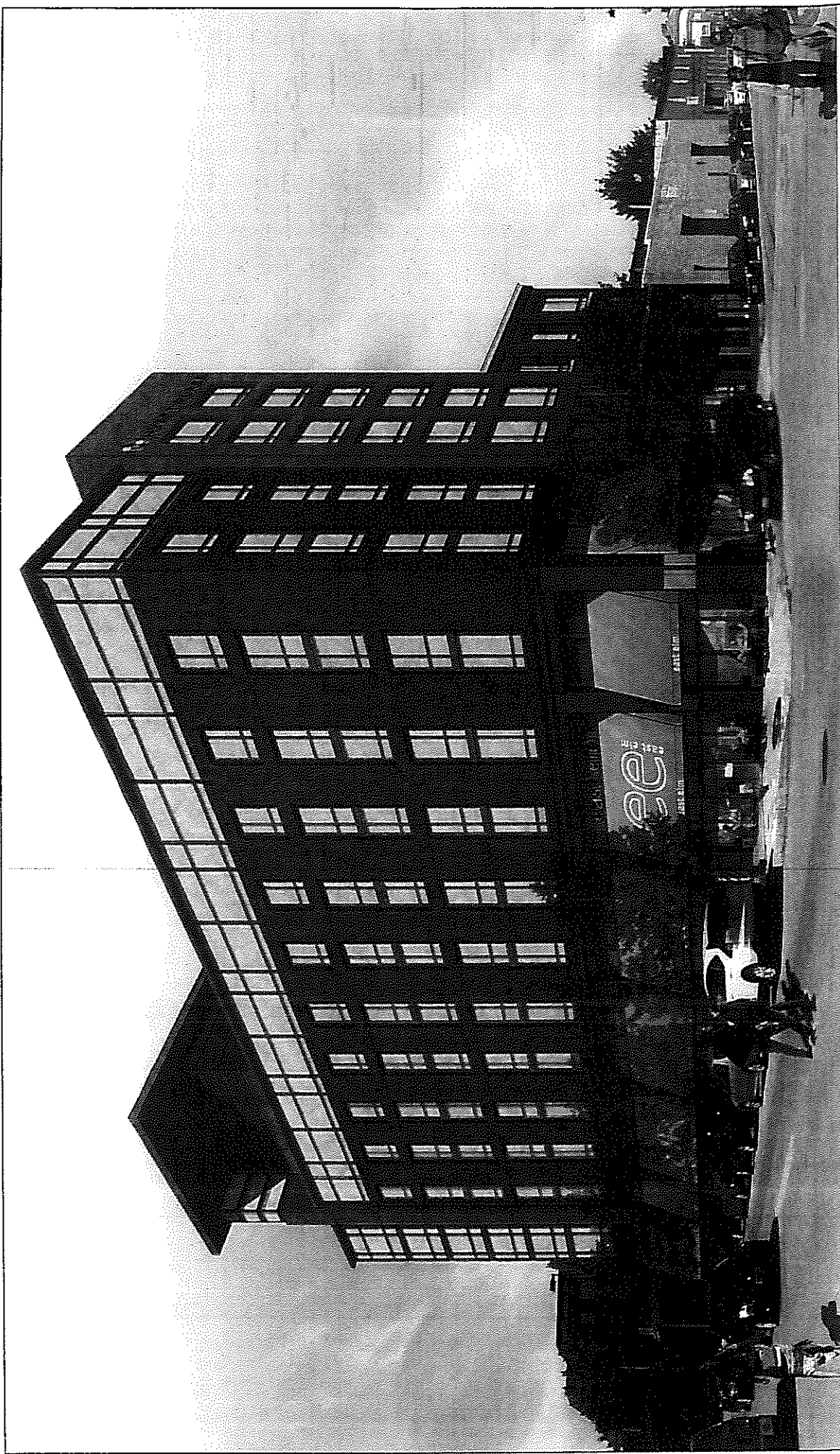

FLEET STREET & EIGHTH STREET - PERMISSIVE
DALLAS METRO AREA EAST TARRANT PLACE
311
10/1/2011

COOPER CARNEY

11/11/11

11/11/11

© 2011 COOPER CARNEY, INC. ALL RIGHTS RESERVED. THIS IS A PERMISSIVE RENDERING. NOT TO BE USED FOR CONSTRUCTION.

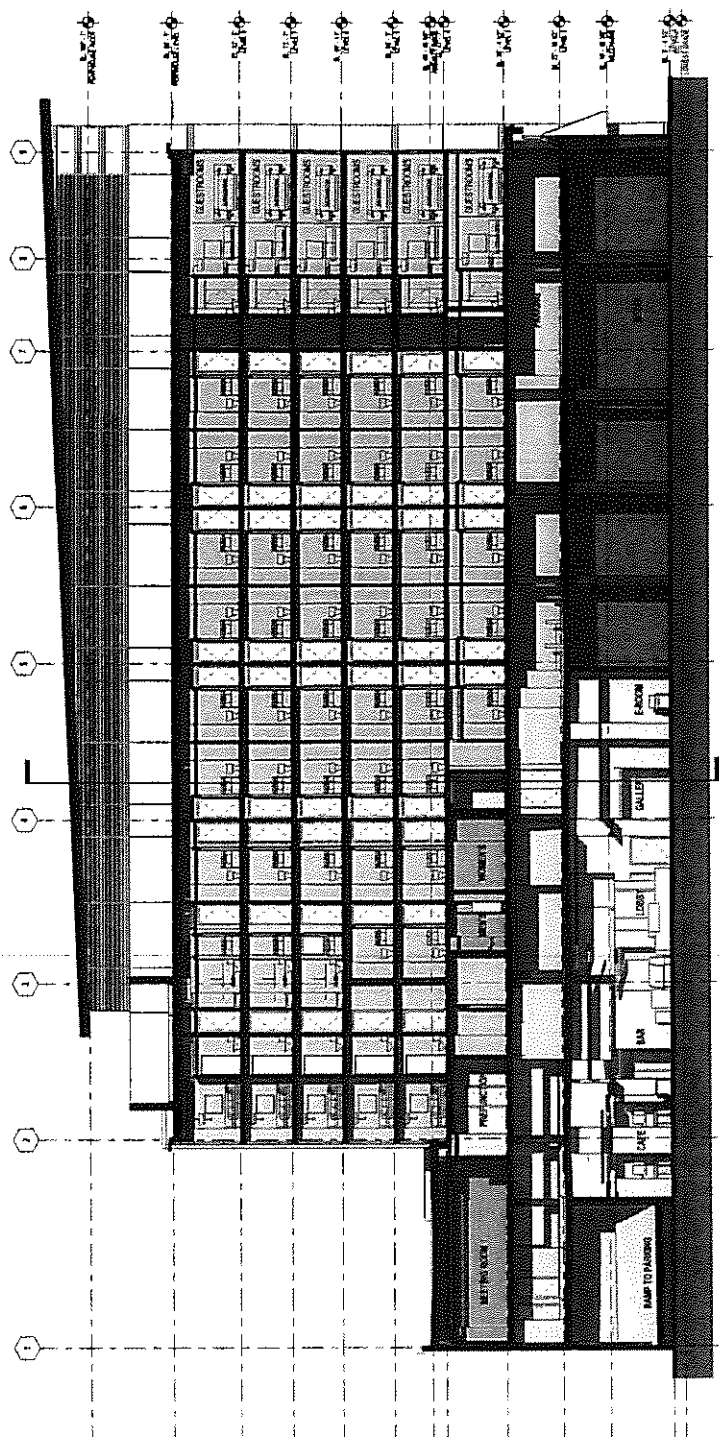

LONGITUDINAL SECTION
 BALTIMORE HARBOR EAST TOWERT PLACE
 1000 EAST TOWERT PLACE
 BALTIMORE, MARYLAND

COOPER CARNEY

DATE: 10/10/00
 DRAWING NO.: 1000-01
 SHEET NO.: 1000-01-01

BY: [Signature]
 CHECKED: [Signature]
 PROJECT: 1000-01-01

TRANSVERSE SECTION
 BATHURST HARBOUR EAST RATT PLACE
 17/18/19/20/21/22/23/24/25/26/27/28

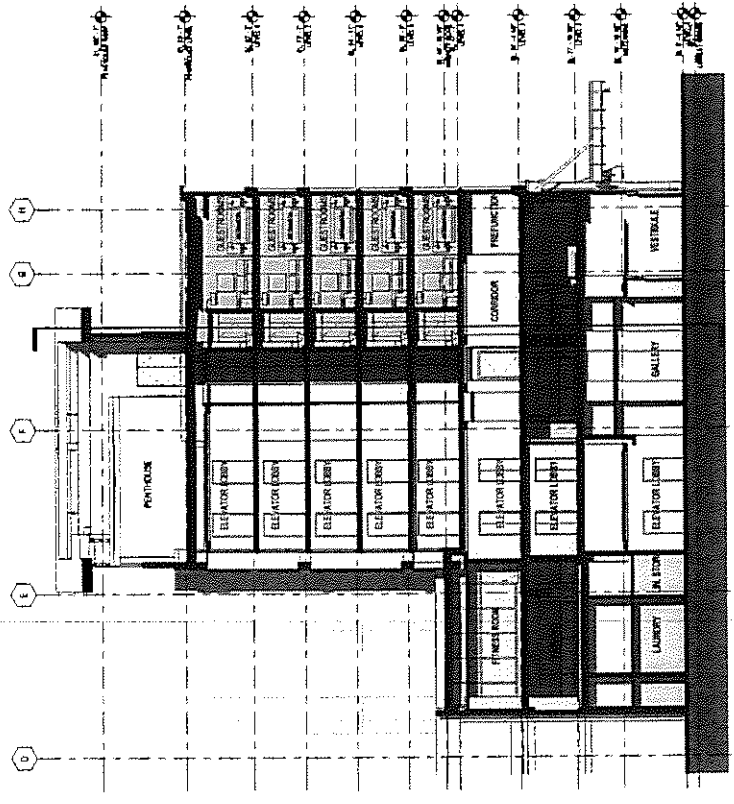

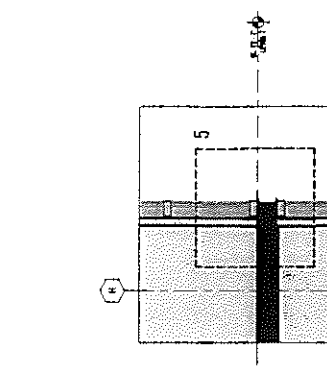

1 TYPICAL WINDOW WALL SECTION
 NOT TO SCALE

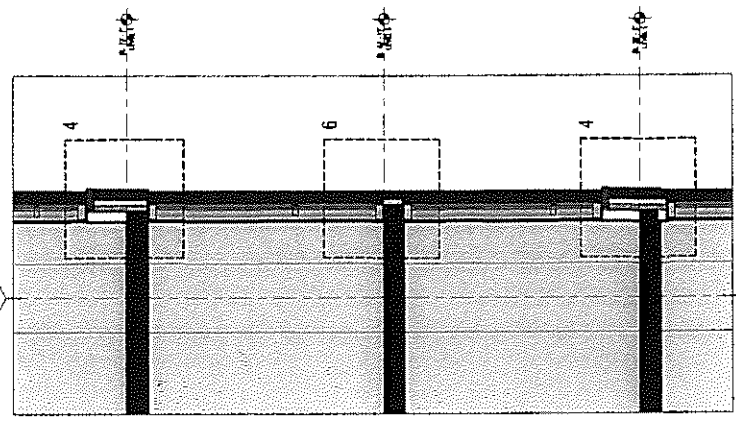

2 TYPICAL BRICK WALL SECTION
 NOT TO SCALE

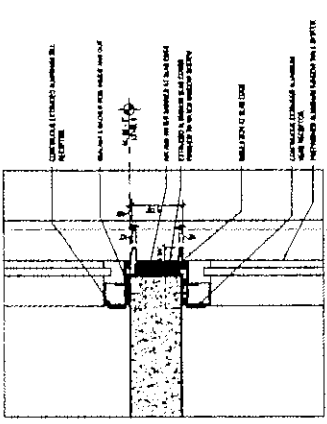

5 TYPICAL DETAIL AT WINDOW WALL SLAB EDGE
 NOT TO SCALE

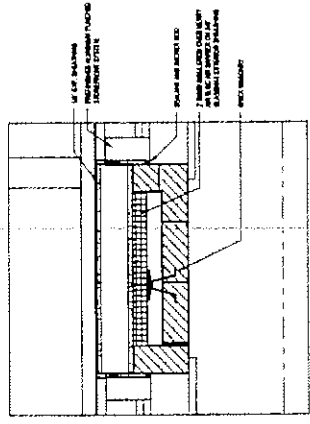

3 TYPICAL BRICK PLAN DETAIL
 NOT TO SCALE

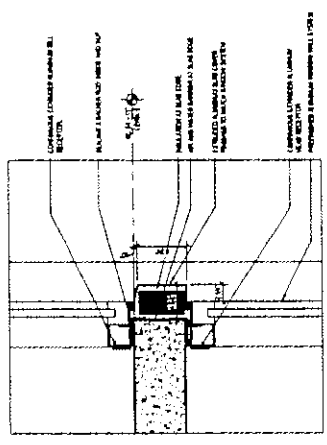

6 TYPICAL DETAIL AT WINDOW SLAB EDGE
 NOT TO SCALE

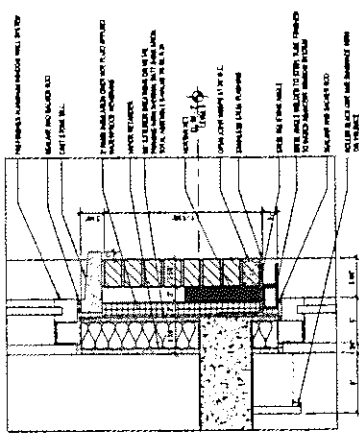

4 TYPICAL DETAIL AT WINDOW SILL AND HEAD
 NOT TO SCALE



Liquor Board System

Version 1.0

Annual-Renewal ▾ | License-Transfer ▾ | One-Day ▾ | Add New License ▾ | Query ▾ | Help ▾

License Detail

Close the License | Print License | Print Renewal Letter | << Go Back

License Info

License Num: **LBHM 001** Cert Num: **0180** Fee: **\$6,500.00** Status: **Renewed**
 License Date: 5/1/2017 License Year: 2017
 CR Number: 15713346
 Payment Date: 04-25-17

2016 - 2017 TPP Paid N
 2017 Trader's License Y Update Info

Click to Start License Renewal

Add Adult Entertainment License

Add New Adult Entertainment License

Location

Corp Name: **INTERSTATE MANAGEMENT COMPANY, LLC**
 Trade Name: **HYATT PLACE**
 Zone Code: 23
 Phone: 410-558-1840

Block Num: 511 Street: **CENTRAL AVENUE SOUTH**
 City: **BALTIMORE** State: **MD** Zip: **21231**

CR Number: 15713346

Portion of Business Used:
 USE PREMISES AS AN 8 STORY HYATT PLACE HOTEL WITH 208 ROOMS AND 2ND FLOOR
 PARKING GARAGE
 Restriction:

Edit the License Location Info | Alternate Mailing Address

License Owners

First Name	Last Name	Street	City	State	Zip	Action	Change Owner
ERICA HILARY	HAGEMAN	9100 WEXFORD DRIVE	VIENNA	VA	22182	Edit	Remove Owner
CARRIE	MCINTYRE	13821 DEAKINS LANE	GERMANTOWN	MD	20874	Edit	Remove Owner
KATHLEEN	WILLIAMS	1347 W. 42ND STREET	Baltimore	MD	21211	Edit	Remove Owner

Comments

Date	Comment	Action
05/24/2017	Trader's Business License for #15780650... /sb	Delete
05/16/2017	Alcohol Awareness expires 10/26/19 (Maurizio Luise)... /sb	Delete
02/03/2015	01/16/15-Paid \$100.00 for hearing scheduled 01/08/15, invoice #95587.	Delete

[Print History (Print Card)]

License num: LBHM 001

Address: 511 CENTRAL AVENUE SOUTH

Trade Name: HYATT PLACE

Comment:

[Add Comment]

Hold Info

Powered by:





Maryland Business Express

[Home](#) [Log In / Create Account](#)

511 SOUTH CENTRAL BEVERAGE, LLC: Z17966052

Business Options:

General Information | [Filing History](#) | [Personal Property](#)

General Information

Department ID Number:

Z17966052

Business Name:

511 SOUTH CENTRAL BEVERAGE,
LLC

Principal Office:

SUITE 300
1575 WELTON ST.
DENVER CO 80202

Resident Agent:

THE CORPORATION TRUST,
INCORPORATED
2405 YORK ROAD
SUITE 201
LUTHERVILLE TIMONIUM MD
21093-2264

Status:

ACTIVE

Good Standing:

THIS BUSINESS IS IN GOOD
STANDING

[» Order Certificate of Status](#)

Business Type:

FOREIGN LLC

Business Code:

ENTITIES OTHER THAN
CORPORATIONS

Date of Formation/ Registration:

04/26/2017

State of Formation:

CO

Stock Status:

N/A

Close Status:

N/A

[New Search](#) [Order Documents](#)

PROPOSED LOCATION: 511 S. Central Ave

MAP SUMMARY (RECAPITULATION)

TOTAL ESTABLISHMENTS IN MAP AREA 14

"A" BEER & WINE _____

"B" BEER & WINE _____

"C" BEER & WINE _____

"D" BEER & WINE 1

"A" BEER, WINE & LIQUOR _____

"A-2" BEER, WINE & LIQUOR _____

"B" BEER, WINE & LIQUOR 9

"C" BEER, WINE & LIQUOR _____

"D" BEER, WINE & LIQUOR _____

"BD7" BEER, WINE & LIQUOR 4

ARENA _____

HOTEL/MOTEL _____

RACING _____

PREPARED BY: [Signature] DATE: 11/20/17

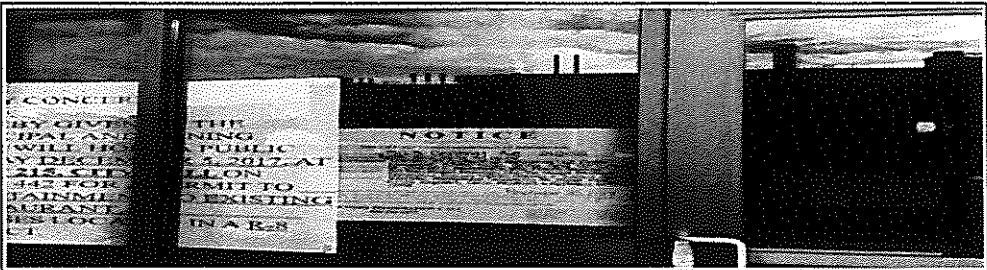
<p>Board of Liquor License Commissioners For Baltimore City 231 E. Baltimore Street, 6th Floor Baltimore, Maryland, 21202-3258</p>	
INSPECTORS REPORT - TRANSFERS/NEW APPLICATIONS	
<i>Licensee Information (Trade Name):</i>	<input type="text" value="Hyatt Place Inner Harbor"/>
<i>Corporation Name:</i>	<input type="text" value="511 South Central Beverage, LLC"/>
<i>Location Address:</i>	<input type="text" value="511 S Central Ave"/>
<i>License Type:</i>	Hotel/Motel License
<i>Is the establishment open and operating in a safe and sanitary manner? (If not open, not in comments - CLOSED or NOT OPERATING)</i>	No
<i>Is the location within 300 feet of Church and/or School?</i>	No
<i>Date Posted?</i>	<input type="text" value="11/15/2017"/>
<i>Date Removed?</i>	<input type="text" value="11/27/2017"/>
<i>Are there any other licensed establishments within a two block radius?</i>	Yes
<i>Other licensed locations - Describe/Note:</i>	
<input type="text" value="see map"/>	
<i>Comments and Follow-up Items(s) (please note any issues or concerns about the location):</i>	
<input type="text" value="Transfer of license (B-BWLHM) to include all public areas, hotel rooms, conference/meeting rooms and storage areas to include live entertainment."/>	
<i>Insert Photo of Sign and location:</i>	
	



Inspector Name	Date and Time	
<input type="text" value="F.O# w/baltimore\john.howard"/>	<input type="text" value="11/20/2017"/>	<input type="text" value="10:54:31 AM"/>
Name of Licensee (if present)		
<input type="text"/>		
<input type="text"/>		

Board of Liquor License Commissioners

For Baltimore City
 231 E. Baltimore Street, 6th Floor
 Baltimore, Maryland, 21202-3258

POSTING SIGNS REPORT

<i>Applicant(s) Name:</i>	Christopher G. Brown,Ivelisse Contreras, Andre G. Warfel
<i>Address of Premises:</i>	511 S Central Ave
<i>Inspector:</i>	[:0#.w baltimore\john.howard
<i>Date Posted:</i>	11/15/2017
<i>Time Posted:</i>	2:00 PM
<i>Date Rechecked:</i>	11/27/2017
<i>Time Rechecked:</i>	9:40 AM
<i>Manager or Owner when sign posted:</i>	Nicholis Velley

Summary on location of sign posted:

Posted on front window near garage entrance.

Summary on location of sign rechecked:

Sign remained in place for the mandatory period of time

Insert Photo of Sign and location:

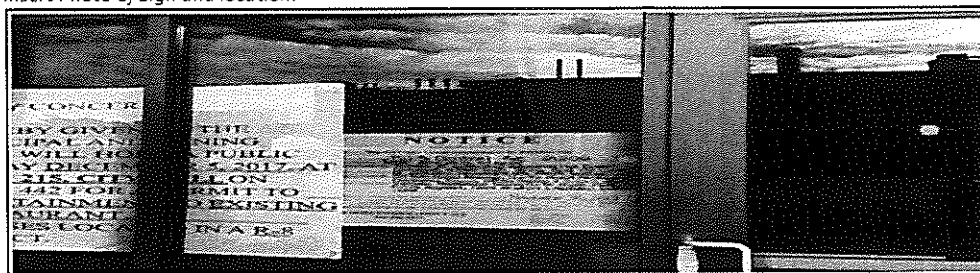

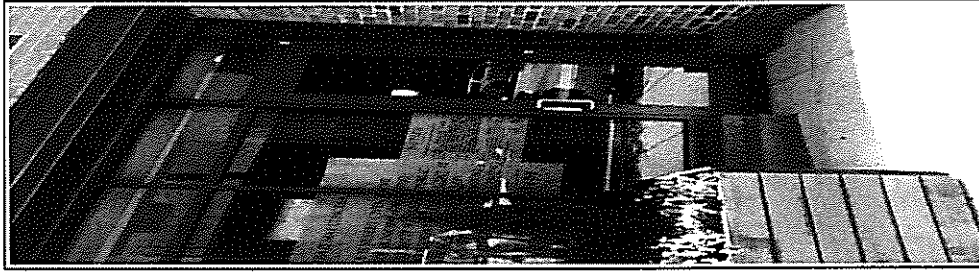
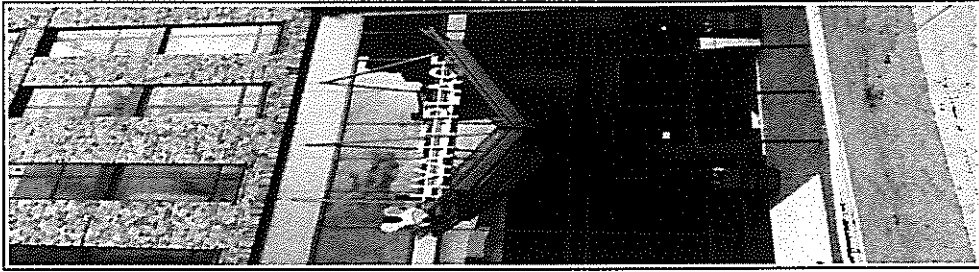

BLLC Routine Inspection

[Redacted]

Address: 511 CENTRAL AVENUE SOUTH 21231

Trade Name: HYATT PLACE

Corporation Name: INTERSTATE MANAGEMENT COMPANY, LLC

Type of License: Hotel/Motel License

Date/Time of Inspection: 11/20/2017 12:42:01 PM

Manager/Licensee: Nicholas Velley

[Redacted]

Open/Closed: Open

Closed Date: [Redacted]

[Redacted]

Clean and Free of Debris: Satisfactory

[Redacted]

Location of Bar: Center

Shape of Bar: [Redacted]

Condition of Bar Area/Floors: Satisfactory

Hot Water: Yes

Disinfectant Solution: Yes

Three Compartment/Washer: Yes

[Redacted]

Bulletproof Partitioning: N/A

Separate Pkg. Goods Dept.: N/A

Separate Pkg. Goods Store: N/A

Bar/Tavern Open and Operating: Yes

Selling Household/Grocery: N/A



Capacity:

Location of Dining Area:

Condition of Dining Area/Floors: Satisfactory

Sanitation: Satisfactory

Menu: Yes



Traders License: Yes

Alcohol Awareness Certification Date Issued: 6/10/2015

Employee Records: Yes

Alcohol Beverage Information Invoice Numbers and Date:



Inspector Comments: Satisfactory



Inspector Comments: Satisfactory



Exits Marked, Unobstructed: Yes

Fire Capacity:

Outdoor Seating Capacity:



License is Valid: N/A

Dancers Present 18 and older: N/A

Cleanliness of Dressing Room: N/A



Live Entertainment (Describe):

Outdoor Table Service N/A



Violation Issued: No

Violations Noted:



Instructions Given to Licensee:

Inspector's Comments: Inspected 11/15/2017

Photo Taken:

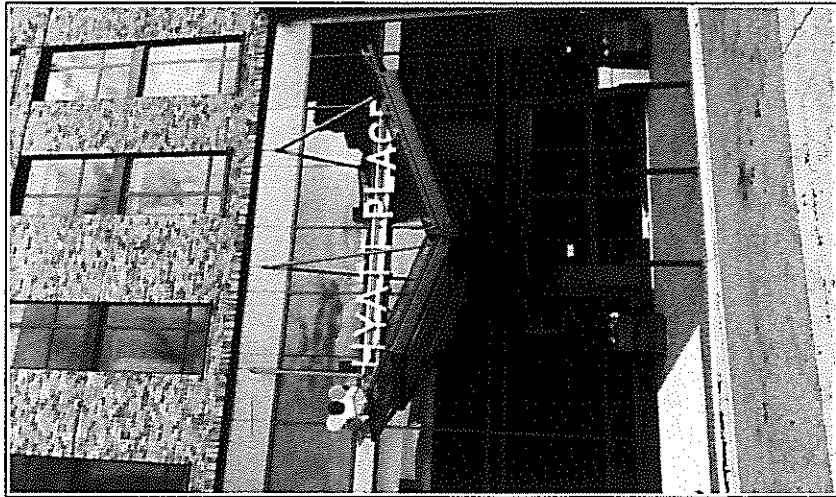

Owner Email:

Submitted by Inspector

Permit - Details

Permit Num.:USE2016-02676

Permit Issued: 3/2/2017 11:23:45 AM

Plan Num:-

Date Final:

Address:511 S CENTRAL AVE

Date Exp:

Block-Lot: 1442 007 (see parcel details)

Last Update:6/7/2016 3:48:38 PM

Zip Code:21202-4372

Estimated Total

Last User:YOUSUF

Cost:

Building Fully Sprinkler:

Existing Use:

Proposed Use:
Type of Work:

Tag Type	Tag Description	Updated By	Date Updated
Zoning Notes	Property re-zoned from M-2-2 district to B-2-3 per Ord. 07-429 enacted 5/17/07.	CLEE	8/10/2012 2:29:15 PM
Non-sufficient Funds	NSF on Rental Registration Voucher #9000005062 on charge back date of 7/11/14 in the total amount of \$180.00. on permit # COM2014-14442. 7/18/14 JRAN * PAID * 9/18/14 \$180.00 PAID ON CASH DEPOSIT SLIP #115123 - RECEIVED BY NT	NTHO	9/18/2014 9:43:22 AM

[see applicant info](#)
[see other agency info](#)

(USE) USE PORTION K/A 1100 FLEET ST, UNIT 102, AS A NEW RESTAURANT WITH ACCESSORY OUTDOOR TABLE SERVICE AS PER BMZ2014-171 APPROVED 6/3/2014 WITH CONDITIONS FOR NOT MORE THAN 22 SEATS AND SIX TABLES THERE WILL BE NO OUT DOOR BAR OR MUSIC

Add Activity

Action	Notes	DISP	ASSIGNED	DATE1	DATE2	DATE3	Done By
Application Received		DONE		6/7/2016 3:49:00 PM		6/7/2016 3:49:00 PM	AYOU
Zoning Sign-off		APP		6/7/2016 3:49:00 PM		6/7/2016 3:49:00 PM	AYOU
CHESAPEAKE CRITICAL AREA		APP	JTAT	6/7/2016		6/7/2016	JTAT
HEALTH DEPARTMENT INSPECTION		APP	XWEL	6/7/2016		2/8/2017	XWEL
MINOR PRIVILEGE	ADDRESS IS 1100 FLEET STREET NOT 511 S. CENTRAL AVENUE MINOR PRIVILEGE PERMIT T116250	APP	MPRV	6/7/2016		2/2/2017	MPRV
Print		DONE		6/7/2016 3:57:00 PM		6/7/2016 3:57:00 PM	FELT
Print		DONE		6/7/2016 3:58:00 PM		6/7/2016 3:58:00 PM	FELT
REMINDER	MOVED TO USE FOLDER	DONE		6/10/2016		6/10/2016 12:48:00 PM	SHKN
Fire Inspection	FIRE DEPARTMENT HAS NO OBJECTION TO THE ADDING OF OUTDOOR SEATING NO MORE THEN 2 TABLES 8 CHAIRS,10 AT OUTDOOR BAR FOR EATING PURPOSES ONLY A TOTAL OF 18 THERE WILL BE NO OUT DOOR BAR OR MUSIC	APP	AJON	2/15/2017	2/15/2017	2/22/2017	AJON
Occupancy Certification	641312-01 ~ VM - Y - ENGLISH CONTACT:MAURICIO 240-441-6669 RESULT:APPROVED FOR USE.	APP	DJON	2/23/2017	3/1/2017	3/1/2017	DJON
Issue Permit		DONE		3/2/2017 11:24:00 AM		3/2/2017 11:24:00 AM	SHKN
REMINDER	MAILED ON 03/02/17 1302 FLEET ST	DONE		3/2/2017		3/2/2017 11:25:00 AM	SHKN
Print		DONE		3/2/2017 3:17:00 PM		3/2/2017 3:17:00 PM	SHKN

Print	DONE	3/2/2017 3:20:00 PM	3/2/2017 3:20:00 PM	SHKN
Print	DONE	4/12/2017 3:03:00 PM	4/12/2017 3:03:00 PM	CROS
Print	DONE	5/23/2017 4:20:00 PM	5/23/2017 4:20:00 PM	EFAU

Department Of Housing And Community Development
Division Of Permits and Code Enforcement

Applicant Copy

No:BMZ2017-00442

Address: 511 S CENTRAL AVE Block/Lot: 1442-007

K/A:

Conditional Uses

\$250.00

Applicant:

Total: \$250.00

Owner/Lessee:

OWN SAGE HOSPITALITY RESOURCES, LLC C/O NICK KELLY Phone
511 S CENTRAL AVE BALTIMORE MD 21202

Contractor:

Expiration:	Work Cost:	201	Work Cost:	201	Minor Privilege:
-------------	------------	-----	------------	-----	------------------

ADD LIVE ENTERTAINMENT TO EXISTING HOTEL AND RESTAURANT.

*****DUPLICATE*****
PD:11/8/2017 CR:210 LOC: WOLM WS: 206
ID:08 TR: 0061 RCT #: 00020370
11/7/2017 1:47PM
PERMIT #:BMZ2017X00442Y
CO AMOUNT PAID: \$250.00
Building Permits \$250.00
CK \$250.00
CHANGE \$0.00

BOARD OF MUNICIPAL AND ZONING APPEALS

14th Floor

417 E. Fayette Street - 21202

Address: 511 S. Central Avenue

Baltimore, MD, November 7 2017

To the Appellant:

Your appeal to the Board of Municipal & Zoning Appeals has been assigned Number 2017- 442 And scheduled for a Public Hearing as indicated on the form below. Hereafter refer to this matter by Appeal Number. **Everything included within the heavy black lines is required to appear on the sign.**

The certificate of posting at bottom of this form shall be dated, signed and filed at the office of the Board prior to the Public Hearing.

Owner/appellant or an authorized representative, previously approved by the Executive Director, must be present at the public hearing.

The sign shall be posted no later than November 14 20 17

By Order of the Board SK

Rule of the Board of Municipal and Zoning Appeals for posting:

POSTING -THE PREMISES SHALL BE POSTED IN ACCORDANCE WITH THE FOLLOWING RULES:

- A. THE SIGN SHALL NOT BE LESS THAN 4 FEET LONG BY 3 FEET HIGH; WITH 2 INCH HIGH BLACK LETTERING, ON WHITE BACKGROUND;
- B. THE SIGN SHALL BE POSTED IN A CONSPICUOUS MANNER NOT OVER TEN (10) FEET HIGH, AND WHERE IT WILL BE CLEARLY VISABLE TO AND LEGIBLE TO THE PUBLIC;
- C. THE SIGN SHALL BE POSTED NOT LATER THAN 21 DAYS PRIOR TO THE DATE OF THE PUBLIC HEARING, AND SHALL BE MAINTAINED IN GOOD CONDITION UNTIL AFTER THE PUBLIC HEARING. THE SIGN MUST BE POSTED ON THE FRONT OF THE PREMISES. UNLESS OTHERWISE DIRECTED.

POST SIGN CONSPICUOUSLY ON FRONT OF PROPERTY

WORDING OF SIGN TO BE POSTED ON PREMISES

To Whom it may Concern:

Notice is hereby given by the Board of Municipal and Zoning Appeals that it will hold a Public hearing Tuesday December 5, 2017, at 1:00 P.M. in **Room 215, City Hall** on Appeal No. 2017 - 442 for a permit to _____

Add live entertainment to existing hotel and restaurant

on these premises located in a R-8 Zoning District.

I hereby certify that the sign was posted on the premises in question in accordance with the above instructions on _____ 20_____

SIGNATURE