

June 15, 2017

**Applicant(s):** Hope Siscoe and Minhye Choi  
Luckyseena, Inc., T/a Seena Wine and Liquors  
2448 N. Charles Street 21218

**Class:** "A" Beer, Wine & Liquor License

Application to transfer ownership.

(a) **Applicant(s) Information:** (1) Hope Siscoe was born in Baltimore, MD in April of 1975. She lives Baltimore, MD; (2) Minhye Choi was born in Seoul, South Korea in April of 1969. She lives in Los Angeles, CA.

(b) **Ownership Breakdown:** (1) Hope Siscoe (1%); and (2) Minhye Choi (99%).

(c) **Purchase Price of Business:** The purchase price of the business was \$430,000. A down payment of \$20,000 was made. \$380,000 to be paid at the time of closing. \$30,000 to be financed at 4% per year for 3 years.

(d) **Qualified Voters:** Janet Woods, Gloria Miller, and Mary Mitchell are qualified Baltimore City voters.

(e) **Zoning:** Applicants have applied for a USE permit, for the continued use of portion of premise, 2448 N. Charles, as a liquor store, under URP for Charles/25<sup>th</sup> Street.

(f) **Corporate Standing:** Luckyseena, Inc. is a MD Corporation and as of 5/23/2017 is active and in good standing.

(g) **Posting Report:** The location was posted on 5/15/2017, and checked on 5/24/2017. This meets the 10-day rule. There are 9 licensed liquor establishments in the 4x4 area: "A" BWL-2; "B" BWL-3; and "BD7" - 4.

(h) **Timeline:** Last Inspection by BLLC was performed 3/10/2017. At that time, the establishment was open and operating.

(i) **Letters of Support/Opposition:** At this time the Board has no letter(s) of opposition or support.

In considering this request, under the provisions of Alcohol Beverages Article 4-210(A) the Board must consider the following factors: 1. The public need and desire for the license; 2. The number and location of existing license holders; 3. The potential effect on existing license holders of the license for which application is made; 4. The potential commonality or uniqueness of the services and products to be offered by the business of the applicant; 5. The impact of the license for which application is made on the health, safety, and welfare of the community, including issues relating to crime, traffic conditions, parking, or convenience; and 6. Any other factor that the local licensing Board considers necessary.

**Board's Decision:**

**OFFICE USE ONLY**  
 Date Filed \_\_\_\_\_  
 Posting Date: \_\_\_\_\_  
 Approved  Yes  No \_\_\_\_\_  
 Withdrawn  Yes  No \_\_\_\_\_  
 WC Information \_\_\_\_\_  
 Policy/Binder# \_\_\_\_\_

**Application for Alcoholic Beverages License**  
**Board of Liquor License Commissioners for Baltimore City**

*NEW/TRANSFER/EXPANSION/AMENDMENT(S) APPLICATION FEE - \$500.00*  
*After June 1, 2016 \$600.00 includes Hearing Fee*

**OFFICE USE ONLY**  
 Status of Zoning Verification  
 Approved: Yes  No   
 Date Sent to Zoning: \_\_\_\_\_  
 Initials: \_\_\_\_\_  
 Zoning Info: \_\_\_\_\_

INDICATE TYPE OF LICENSE APPLICATION: TRANSFER  NEW  EXPANSION OF PREMISES  AMENDMENT(S)   
 EXPLANATION OF REQUEST: Request for Transfer from DDAA, Inc. CLASS TYPE: A  
 LICENSE AT THE LOCATION: 2448 Charles St., North IF TRANSFER, PREVIOUS LOCATION: 2448 N Charles St.  
 CORPORATE/LLC/LLP/PARTNERSHIP NAME: Luckyseena, Inc. TRADE NAME: Seena Wine and Liquors  
 BUSINESS PHONE NUMBER: 410-243-0045 BUSINESS CONTACT/MANAGER: Minhye Choi  
 ATTORNEY FOR THE APPLICANT: Jay S. Yoo ADDRESS: 3440 Ellicott Ctr. Dr. #202 PHONE: 410-465-3606  
Ellicott City, MD 21043

Part of Premises Used (Note: Floors and Areas for Storage): portion of premises 2448 N. Charles Street

Will Live Entertainment be provided?  Yes  No What Kind (Ex. DJ, Band, Etc.)? \_\_\_\_\_

Will Outdoor Table Service Be Provided?  Yes  No

Off Premise Catering of Food and Alcohol?  Yes  No BLLC Catering Application Filed?  Yes  No

Delivery of alcohol?  Yes  No BLLC Delivery Application Filed?  Yes  No

*Please note that as per Art. 2B §10-202(a)(iv)(1) that an application for the issuance or transfer is not complete unless the applicant has obtained zoning approval from the City of Baltimore. Please attach Use and Occupancy Permit or letter from BMZA approving use.*

**I. Applicant A**

Hope Siscoe \_\_\_\_\_  
 (Full name) \_\_\_\_\_ (Telephone no.) \_\_\_\_\_ E-mail (Required) \_\_\_\_\_  
2300 N. Dukeland St., Balto, MD 21216 \_\_\_\_\_  
 (Residence) Street City State Zip Code (period of residency in Baltimore City) \_\_\_\_\_  
4/1/1975 \_\_\_\_\_  
 (Month/Year of Birth) (Sex: Male or Female) (Place of Birth) \_\_\_\_\_  
Female \_\_\_\_\_  
Baltimore City \_\_\_\_\_  
 Check:  Yes  No Have you been a resident and taxpayer of the City of Baltimore for 2 years preceding this application?  
 Yes  No Are you a registered voter in the City of Baltimore?

**2. Applicant B**

minhye choi \_\_\_\_\_  
 (Full name) \_\_\_\_\_ (Telephone no.) \_\_\_\_\_ E-mail (Required) \_\_\_\_\_  
540 S. Catalina St, Apt. 318, Los Angeles CA 90020 \_\_\_\_\_  
 (Residence) Street City State Zip Code (period of residency in Baltimore City) \_\_\_\_\_  
4/1/1969 \_\_\_\_\_  
 (Month/Year of Birth) (Sex: Male or Female) (Place of Birth) \_\_\_\_\_  
Female \_\_\_\_\_  
Seoul, S. Korea \_\_\_\_\_  
 Check:  Yes  No Have you been a resident and taxpayer of the City of Baltimore for 2 years preceding this application?  
 Yes  No Are you a registered voter in the City of Baltimore?

**3. Applicant C**

\_\_\_\_\_  
 (Full name) \_\_\_\_\_ (Telephone no.) \_\_\_\_\_ E-mail (Required) \_\_\_\_\_  
 \_\_\_\_\_  
 (Residence) Street City State Zip Code (period of residency in Baltimore City) \_\_\_\_\_  
 \_\_\_\_\_  
 (Month/Year of Birth) (Sex: Male or Female) (Place of Birth) \_\_\_\_\_  
 Check:  Yes  No Have you been a resident and taxpayer of the City of Baltimore for 2 years preceding this application?  
 Yes  No Are you a registered voter in the City of Baltimore?

1. Has the applicant(s) been adjudged guilty of a felony in the State of Maryland or any other?  Yes  No - If yes, indicate applicant and explain.  
Applicant A  B  C

2. Has the applicant(s) been adjudged guilty of violating the laws governing the sale of any alcoholic beverage or for gambling in any State, including Maryland?  Yes  No - If yes, mark applicant and provide explanation in adjacent space provided.  
Applicant A  B  C

3. State whether the applicant(s) has ever been adjudged guilty of any offense against the laws of the State of Maryland or the United States.  
 Yes  No - If yes, mark applicant and explain.  
Applicant A  B  C

4. Has the applicant(s) ever had a license for the sale of alcoholic beverages in the State of Maryland?  Yes  No If yes, mark applicant and explain.  
Applicant A  B  C

5. Has the applicant(s) ever had a liquor license suspended or revoked?  Yes  No If yes, mark applicant and explain.  
Applicant A  B  C

6. Does the applicant(s) have a pecuniary interest in any other alcoholic beverage business or business for which an alcoholic beverage license has been applied for, granted, and issued?  Yes  No If yes, mark applicant and explain.  
Applicant A  B  C

7. Do the spouses or children of any of the applicant(s) have a financial interest in any other alcoholic beverages license or business in Baltimore City or any other jurisdiction in the State of Maryland?  Yes  No If yes, mark applicant and explain.  
Applicant A  B  C

8. Are you financially interested in any other alcoholic beverages license applied, granted or issued?  Yes  No If yes, please explain.  
Applicant A  B  C

9. Is the licensed premise currently open and operating?  Yes  No If yes, please explain.

10. Do any of the applicant(s) - personally or through an entity - have any indebtedness or other financial obligations to any manufacturer, brewer, distiller, or wholesaler at the time of making this application?  Yes  No If yes, please explain. If yes, please provide information as to the applicant(s) indebted - personally or through an entity - the amount of the indebtedness, and the name of the manufacturer, brewer, distiller, or wholesaler?

Applicant A  B  C

11. Please list the following information for the Manager of the establishment to be licensed:

Name	Address	Phone	Email
Minhye Choi	540 S. Catalina St. Apt. 318, LA, CA 90020	[REDACTED]	[REDACTED]

Applicants Applying as Business Entities - (Give name(s) and addresses - in Corporation list all officers (attach list if necessary) or in Limited Liability Company/Partnerships list all authorized persons.) Please note that all licensees MUST have a pecuniary interest in the license applied for as per Article 2B Section 10-103(b) (10)

- 1) NAME: Hope Siscoe ADDRESS: 2300 N. DuKeland St., Baltto, md 21216 TITLE: Assistant Secretary %OF STOCK HELD RESIDENCE: 1%
- 2) NAME: Minhye Choi ADDRESS: 540 S. Catalina St., Apt 318, LA, CA 90020 TITLE: President %OF STOCK HELD RESIDENCE: 99%
- 3) NAME: \_\_\_\_\_ ADDRESS: \_\_\_\_\_ TITLE: \_\_\_\_\_ %OF STOCK HELD RESIDENCE: \_\_\_\_\_
- 4) NAME: \_\_\_\_\_ ADDRESS: \_\_\_\_\_ TITLE: \_\_\_\_\_ %OF STOCK HELD RESIDENCE: \_\_\_\_\_

\*\*\*\*\*Attached is a list of the names and addresses of all outstanding stockholders who on the day of this application own more than 5% of the outstanding stock of the corporation and the articles of incorporation, partnership agreement or articles of organization.\*\*\*\*\*

*\*Extract from Law: If any affidavit or oath required under the provisions of this Act shall contain any false statements, the offender shall be deemed guilty of perjury. And upon indictment and conviction thereof, shall be subject to penalties provided by Law for that crime.*

**CERTIFICATE OF APPLICANTS:** At least one applicant whose signature appears below certifies that he/she has been a resident and taxpayer of Baltimore City, Maryland for at least two years preceding the filing of this application. Each of said applicants hereby certifies further that if the license applied for is granted, he/she will conform to all State and County laws and regulations relating to the sale of alcoholic beverages, as well as to the rules and regulations of the Board of License Commissioners for Baltimore City, and hereby grants permission to the State Comptroller, his duly authorized deputies, inspectors and clerks, The Board of License Commissioners for Baltimore City, its duly authorized agents and employees, and any peace officer of Baltimore City or the State of Maryland to inspect and search at any and all hours, without warrant, the premises and any and all parts thereof upon and in which said business is to be conducted.

Signature of Applicant A: [Signature] Signature of Applicant B: [Signature] Signature of Applicant C: \_\_\_\_\_

State of Maryland: Howard Co. ss  
 THIS CERTIFIES, THAT ON THE 31<sup>st</sup> OF December 2016  
 before the subscriber a notary public of the State of Maryland, personally appeared  
Hope Siscoe and Minhye Choi  
 The applicant (s) names in the foregoing application, and made oath in due form of law that the statement therein are true to the best of (his, her, their) knowledge and belief.

Jay S. Yoo  
 NOTARY PUBLIC  
 Howard County, Maryland  
 (Witness my hand and seal Expires 04/30/2017)  
[Signature]  
 Notary Public

Name and Address of the owners of the premise/landlord: 2436 North Charles Street, LLC Phone Number: [REDACTED]

STATEMENT OF OWNER OF PREMISES REQUIRED IN CONNECTION WITH ALCOHOLIC BEVERAGES LAW OF MARYLAND  
 (I/WE) Alan Stern, managing mbr. HEREBY CERTIFY, That (I/am we are) the owner(s) of the property located at 2448 N. Charles Street, Baltimore, City with a Zip Code of 21218 which is named in the present application made to Board of Liquor License Commissioners of Baltimore City under the Alcoholic Beverage Laws of Maryland and assent to the granting of the license applied for, and hereby authorize the State Comptroller, his duly authorized deputies, inspectors and clerks, the Board of Liquor License Commissioners of Baltimore City, its duly authorized agents

and employees, and any peace officer of the City of Baltimore and State of Maryland, to inspect and search, without warrant, the premises upon which the business is to be conducted, and any and all parts of the building in which said business is to be conducted, at any and all hours.

(Witness (my, our) hand(s) and seal(s) this 11<sup>th</sup> day of January in the year of 2017.

WITNESS: \_\_\_\_\_ x Alan Stern, managing member

STATE OF MARYLAND  
THIS CERTIFIES, THAT ON 11<sup>th</sup> day of January, 2017  
Before the subscriber a notary public of the State of Maryland, personally appeared Alan Stern,  
managing member of 2436 North Charles Street, LLC  
and acknowledge the execution of the foregoing statement to be his willful, free, voluntary act.

(Witness my hand and seal)  
Notary Public [Signature]  
NOTARY PUBLIC  
Howard County, Maryland  
My Commission Expires 04/30/2017

**The following certificates must be signed by at least 3 persons.**

We, the undersigned citizens, real estate owners and registered voters in the City of Baltimore in which the business covered by the present application is to be conducted, certify that the qualifying applicant(s) is/are personally known to us and has been a resident or a taxpayer of Baltimore City and a resident of the State of Maryland for 2 years preceding this application.

Names	Address	Signature	DOB (Month/Year)	Length of time Acquainted with the Applicant(s)
Janet Woods	2805 Clifton Ave Balto., MD 21216	<u>[Signature]</u>	10-55	2 year
Gloria Miller	2815 Walbrook Ave Balto., MD 21216	<u>[Signature]</u>	10-48	1 year
Mary Mitchell	2202 N. Dukeland St. Balto., MD 21216	<u>[Signature]</u>	1-33	3 year

Board of Liquor License Commissioners for the City of Baltimore,  
231 East Baltimore Street, 6<sup>th</sup> Floor, Baltimore, Maryland 21202  
Phone: 410-396-4377 Fax: 410-396-4382

Please note that this is a public document and upon request will be provided to the general members of the public.

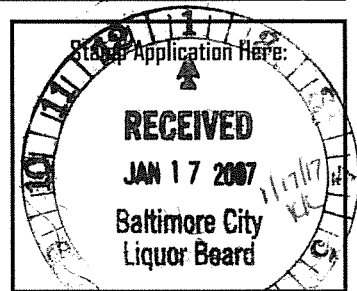

**\*Please present/draw a Floor Plan/Rendering of the Licensed Premises here. If you have a professionally drafted rendering, please attach it to the application.\***

FLOOR PLAN

Seena Wine + Liquors, 2448 N. Charles St.

Ground Floor

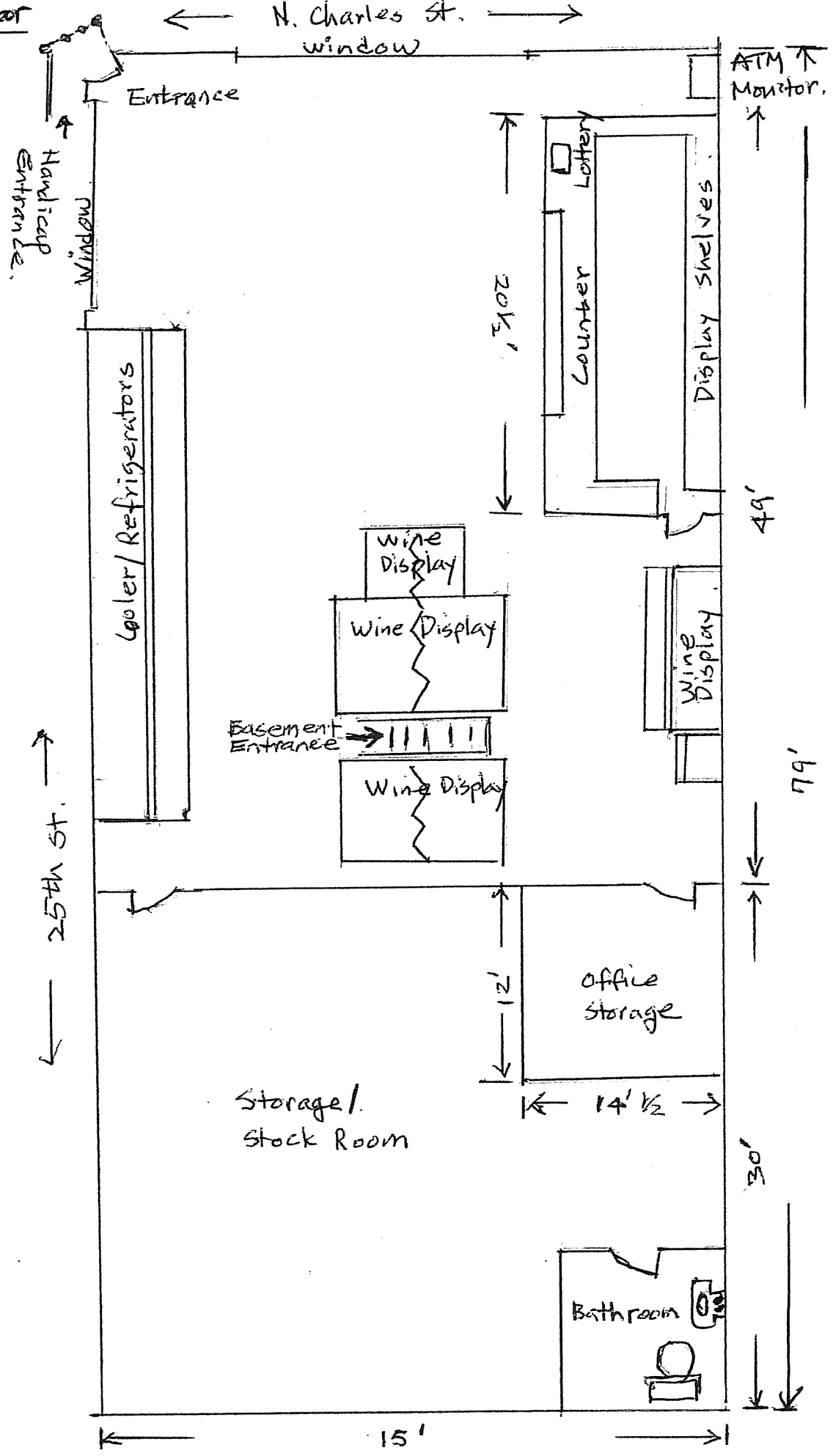



## Liquor Board System

Version 1.0

Annual-Renewal ▾ | License-Transfer ▾ | One-Day ▾ | Add New License ▾ | Query ▾ | Help ▾

### License Detail

#### License Info

License Num: **LA 039**      Cert Num: **0488**      Fee: **\$858.00**      Status: **Renewed**  
 License Date: 5/1/2017      License Year: 2017  
 CR Number: 10301861  
 Payment Date: 04-26-17

2016 - 2017 TPP Paid  Y  
 2017 Trader's License  Y     

### Add Adult Entertainment License

#### Location

Corp Name: **ODAA, INC.**  
 Trade Name: **SEENA WINES AND LIQUORS**  
 Zone Code: 21  
 Phone: 410-243-4445

Block Num: 2448      Street: CHARLES STREET NORTH  
 City: BALTIMORE      State: MD      Zip: 21218

CR Number: 10301861

Portion of Business Used:  
 USE PORTION OF PREMISES 2448 N. CHARLES STREET AS A LIQUOR STORE AS PER  
 BMZA2011-438 APPROVED WITH CONDITION OF CHARLES VILLAGE CIVIC ASSOCIATION  
 Restriction DATED 10/25/11

#### License Owners

First Name	Last Name	Street	City	State	Zip	Action	Change Owner
FEYISE	DESSALEGNE	6800 LIBERTY ROAD APT. 511	BALTIMORE	MD	21207	<input type="button" value="Edit"/>	<input type="button" value="Remove Owner"/>
ABEBECH	KUMBI	27 E. 25TH 1/2 STREET	BALTIMORE	MD	21218	<input type="button" value="Edit"/>	<input type="button" value="Remove Owner"/>

#### Sunday License

License Num:      Cert Num:      Fee:  
 License  
 Date:

Dates.

**Comments**

Date	Comment	Action
10/11/2011	10/6/2011 Public Hearing re: Application to transfer location of Class "A" BWL license presently located at 38 25th St. East unit 102 to the new location 2448 Charles St N. GRANTED.	Delete
09/13/2011	9/11 Transfer of location from 38 E. 25th Street to 2448 N. Charles Street, A-B&W liquor license, Feyise Dessalegne, Daniel Ghebrekidan, ODAA, Inc.	Delete
06/19/2006	06/09/06 FINE \$1125 PAID IN FULL #57072	Delete
06/19/2006	06/08/06 Public hearing re: Violation of rule 4.01(a) DECISION: GUILTY \$1000 OR 10 DAYS + \$125 ADM.FEE = \$1125	Delete
06/21/2005	06/20/05 Public hearing re: Violation of rule 4.01(a) DECISION: GUILTY \$500 OR 5 DAYS SUSPENDED \$200. FINE \$300 OR 3 DAYS + \$125 ADM.FEE = \$425	Delete

Print History (Print Card)

License num: LA 039                      Address: 2448 CHARLES STREET NORTH  
Trade Name: SEENA WINES AND LIQUORS

Comment:

Add Comment

**Hold Info**

Powered by:





Maryland Department of Assessments and Taxation Business Services (w2)

[Search Help](#)

Entity Name: LUCKYSEENA, INC.

Department ID: D17686767

General Information      Amendments      Personal Property      Certificate of Status

Principal Office (Current):	2448 NORTH CHARELS STREET BALTIMORE, MD 21218
Resident Agent (Current):	JAY S YOO 3440 ELLICOTT CENTER DRIVE SUITE 202 ELLICOTT CITY, MD 21043
Status:	INCORPORATED
Good Standing:	Yes What does it mean when a business is not in good standing or forfeited?
Business Code:	Ordinary Business - Stock
Date of Formation or Registration:	12/28/2016
State of Formation:	MD
Stock/Nonstock:	Stock
Close/Not Close:	Close

PROPOSED LOCATION: 2448 N. CHARLES ST

## MAP SUMMARY (RECAPITULATION)

TOTAL ESTABLISHMENTS IN MAP AREA 9

"A" BEER & WINE \_\_\_\_\_

"B" BEER & WINE \_\_\_\_\_

"C" BEER & WINE \_\_\_\_\_

"D" BEER & WINE \_\_\_\_\_

"A" BEER, WINE & LIQUOR 2

"A-2" BEER, WINE & LIQUOR \_\_\_\_\_

"B" BEER, WINE & LIQUOR 3

"C" BEER, WINE & LIQUOR \_\_\_\_\_

"D" BEER, WINE & LIQUOR \_\_\_\_\_

"BD7" BEER, WINE & LIQUOR 4

ARENA \_\_\_\_\_

HOTEL/MOTEL \_\_\_\_\_

RACING \_\_\_\_\_

PREPARED BY: Jeff Ray DATE: May 15, 2017

# 2448 N. CHARLES STREET

## LICENSED ESTABLISHMENTS

- COACH'S RONDEZVOUS LBD
- Charles Village Discount Liquors ABWL
- NEW TERRA CAFE LB
- Ottohar BD7
- Paul Chen Hong Kong Restaurant LB
- SEENA WINE AND LIQUOR ABWL
- ST. MARY'S BAR & RESTAURANT BD7
- VASACHY BD-7
- Yum's Asian Bistro LB

## TRANSFER/OWNERSHIP

- Charmington's
- Ottohar
- St. Mary's Restaurant & Bar
- Bank of America Financial Center
- CVS
- GameStop
- Brown Rice Safeway
- St. Paul's

## CHURCHES AND SCHOOLS

- New Antioch Baptist Church

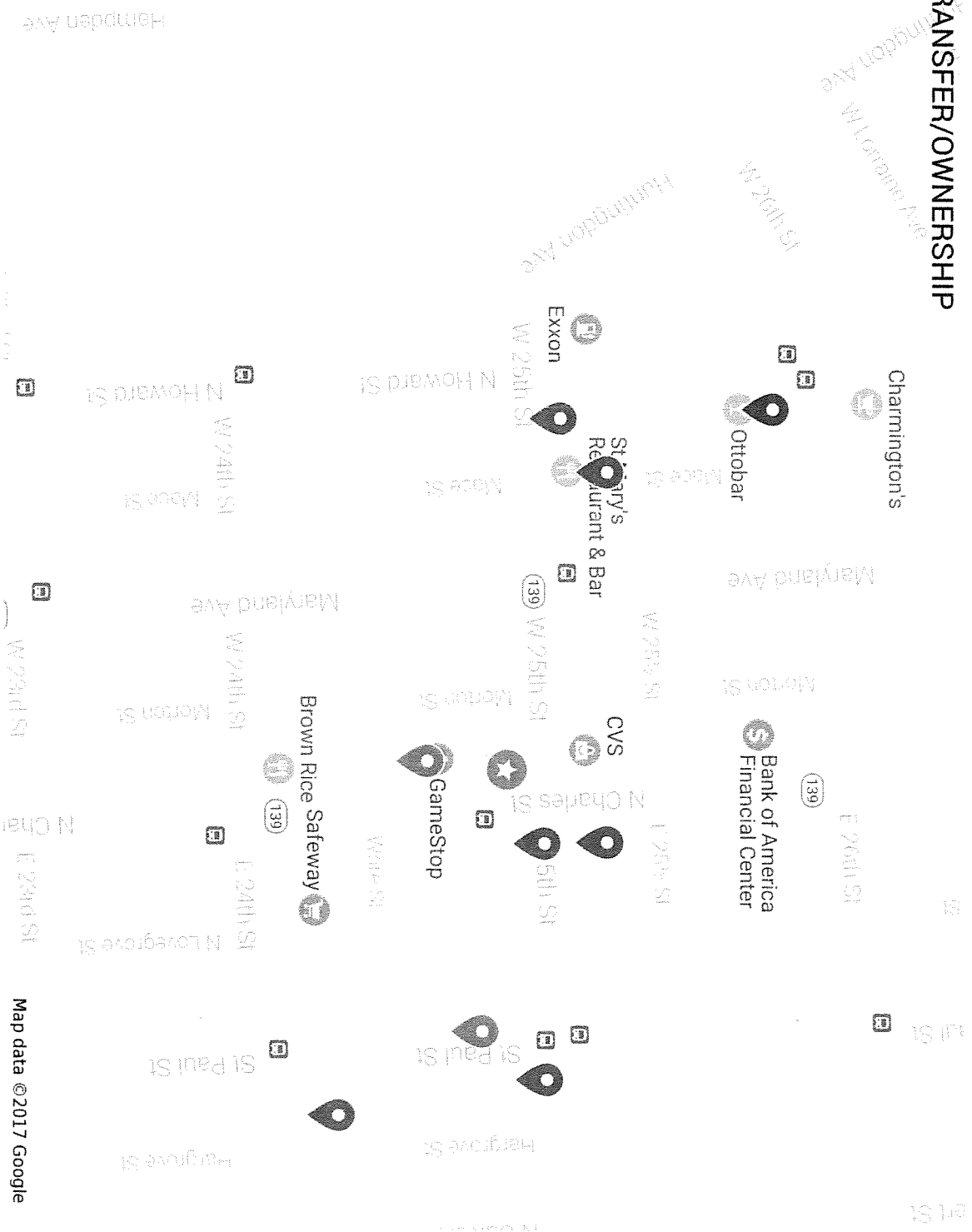

## Board of Liquor License Commissioners

For Baltimore City  
231 E. Baltimore Street, 6<sup>th</sup> Floor  
Baltimore, Maryland, 21202-3258

### INSPECTORS REPORT - TRANSFERS/NEW APPLICATIONS

<i>Licensee Information (Trade Name):</i>	<input type="text" value="Seena Wine and Liquors"/>
<i>Corporation Name:</i>	<input type="text" value="Lucky seena, Inc"/>
<i>Location Address:</i>	<input type="text" value="2448 N Charles Street"/>
<i>License Type:</i>	Class "A" Beer, Wine and Liquor ▼
<i>Is the establishment open and operating in a safe and sanitary manner? (If not open, not in comments - CLOSED or NOT OPERATING)</i>	Yes ▼
<i>Is the location within 300 feet of Church and/or School?</i>	No ▼
<i>Date Posted?</i>	<input type="text" value="5/15/2017"/> <small>12</small>
<i>Date Removed?</i>	<input type="text"/> <small>13</small>
<i>Are there any other licensed establishments within a two block radius?</i>	Yes ▼

*Other licensed locations - Describe/Note:*

Please See map for additional locations.

*Comments and Follow-up Items(s) (please note any issues or concerns about the location):*

Filed application to transfer of ownership.

*Insert Photo of Sign and location:*

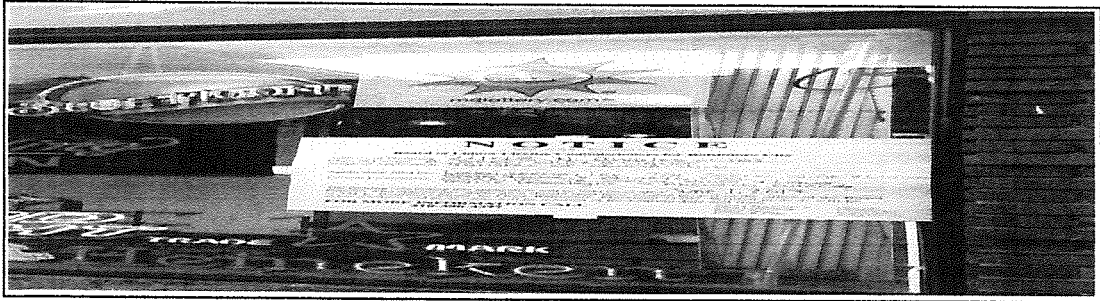

## Board of Liquor License Commissioners

For Baltimore City

231 E. Baltimore Street, 6<sup>th</sup> Floor

Baltimore, Maryland, 21202-3258

### POSTING SIGNS REPORT

<i>Applicant(s) Name:</i>	<input type="text" value="Hope Siscoe; Minhye Choi"/>
<i>Address of Premises:</i>	<input type="text" value="2448 N Charles Street"/>
<i>Inspector:</i>	<input type="text" value="i:0#.w baltimore\darryl.clark"/>
<i>Date Posted:</i>	<input type="text" value="5/15/2017"/>
<i>Time Posted:</i>	<input type="text" value="2:00 PM"/>
<i>Date Rechecked:</i>	<input type="text" value="5/24/2017"/>
<i>Time Rechecked:</i>	<input type="text" value="5:00 PM"/>
<i>Manager or Owner when sign posted:</i>	<input type="text"/>

*Summary on location of sign posted:*

Sign Posted on front left hand side of door.

*Summary on location of sign rechecked:*

The sign is still posted on the front left hand side facing the door.

*Insert Photo of Sign and location:*



## BLLC Routine Inspection

<i>Address:</i>	2448 CHARLES STREET NORTH 21218	▼
<i>Trade Name:</i>	SEENA WINES AND LIQUORS	
<i>Corporation Name</i>	ODAA, INC.	
<i>Type of License:</i>	Class "A" Beer, Wine and Liquor	▼
<i>Date/Time of Inspection:</i>	3/10/2017	11:13:46 AM
<i>Manager/Licensee</i>	Abebech Klembi	
<i>Open/Closed:</i>	Open	▼
<i>Closed Date:</i>		
<i>Clean and Free of Debris:</i>	Satisfactory	▼
<i>Location of Bar:</i>	N/A	▼
<i>Shape of Bar:</i>		
<i>Condition of Bar Area/Floors:</i>	N/A	▼
<i>Hot Water:</i>	N/A	▼
<i>Disinfectant Solution:</i>	N/A	▼
<i>Three Compartment/Washer:</i>	N/A	▼
<i>Bulletproof Partitioning:</i>	Yes	▼
<i>Separate Pkg. Goods Dept.:</i>	N/A	▼
<i>Separate Pkg. Goods Store:</i>	Yes	▼
<i>Bar/Tavern Open and Operating:</i>	Yes	▼

Selling Household/Grocery: Yes ▼

Capacity:

Location of Dining Area:

Condition of Dining Area/Floors: N/A ▼

Sanitation: N/A ▼

Menu: N/A ▼

Traders License: Yes ▼

Alcohol Awareness Certification Date Issued: 8/11/2013

Employee Records: Yes ▼

Alcohol Beverage Information Invoice Numbers and Date:

Inspector Comments:

Inspector Comments:

Exits Marked, Unobstructed: Yes ▼

Fire Capacity:

Outdoor Seating Capacity:

License is Valid:

N/A ▼

*Dancers Present 18 and older:* N/A ▼

*Cleanliness of Dressing Room:* N/A ▼

*Live Entertainment (Describe):*

*Outdoor Table Service* N/A ▼

*Violation Issued:* No ▼

*Violations Noted:*

*Instructions Given to Licensee:*

*Inspector's Comments:* *The establishment is open and operating*

*Photo Taken:*





 Attach Additional Photos

Owner Email:

Submitted by Inspector

[Update/Resubmit](#)

[Print View](#)

# Certificate of Occupancy

THIS WRITTEN INSTRUMENT, WHEN PROPERLY VALIDATED, CONSTITUTES AUTHORITY FOR DOING OR RECEIVING THE THINGS INDICATED BY THE FEES OR CHARGES SHOWN IN THE APPROPRIATE SPACES BELOW AND ALL THINGS TO BE DONE OR RECEIVED UNDER THIS WRITTEN INSTRUMENT SHALL BE DONE OR RECEIVED IN STRICT COMPLIANCE WITH THE APPLICATION HERETOFORE FILED IN THIS DEPARTMENT OF AUTHORITY CONTAINED HEREIN, INCLUDING ANY AND ALL APPROVED DRAWINGS AND OTHER DATA OR INFORMATION ATTACHED THERETO, AND SUBJECT TO ANY AND ALL LAWS, ORDINANCES, RULES AND REGULATIONS IN EFFECT IN THE CITY OF BALTIMORE AND THE STATE OF MARYLAND. WARNING: IT IS UNLAWFUL TO WORK BETWEEN THE HOURS OF 7:00 PM AND 7:00 AM WITHIN 300 FEET OF A DWELLING.

WARNING: IT IS UNLAWFUL TO CONCEAL ANY WORK UNTIL INSPECTED AND APPROVED BY THIS DEPARTMENT.

WARD	SEC.	BLOCK	LOT	ISSUE DATE	DISTRICT
12	06	3624	033	11/29/11	503

PROPERTY ADDRESS: 2436-2448 N CHARLES ST

K/A ADDRESS: 2448 N CHARLES ST

OWNER: 2436 NORTH CHARLES STREET, LLC ADDR: 265 CANAL ST, STE 601A NEW

LESSEE: ODA A INC SEENA WINES & LIQUORS ADDR: 6800 LIBERTY HEIGHTS AVI

LAND USE CODES 5920 0000 0000 0000

(USE)THE PORTION OF THE PREMISES, 2448 N CHARLES ST, AS A LIQUOR STORE . AS PER BMZA2011-438 APPROVED ON OCT25/2011 APPROVED WITH CONDITION OF THE CHARLES VILLAGE CIVIC ASSOCIATION LETTER DATED OCT25/2011.

\*AWC PER PLANNING - ANY NEW FIXED SECURITY GRILLES AND SCREENS FOR STOREFRONT WINDOWS MUST BE LOCATED ON THE INSIDE OF THE WINDOWS AND BE OPENED/REMOVED WHEN THE BUSINESS IS OPEN. ANY NEW SIGNS ASSOCIATED WITH THIS BUSINESS MUST ALSO CONFORM TO THE REGULATIONS OF THE URP. THE TOTAL AREA OF ALL THE SIGNS, POSTERS, PLACARDS, AND GRAPHIC DISPLAYS LOCATED IN A DISPLAY WINDOW MUST NOT TAKE UP MORE THAN 25% OF THE AREA OF THAT WINDOW.

1001-000000-2600-159600-400560 PER. INSP.	1001-000000-2600-158009-400480 MISC.	1001-000000-2600-158009-400480 CH. USE	1001-000000-2600-158301-400490 NEW BLDG.	1001-000000-2600-158302-400490 0 ADDITIONS
		45.00		
1001-000000-2600-158302-400490 ALTERATIONS	1001-000000-2600-158304-400490 REPAIRS	1001-000000-2600-158304-400490 MISC. CONST.	1001-000000-2600-158800-400500 ELECT.	1001-000000-2600-158901-400510 HYDRONIC/STEAM HEAT
1001-000000-2600-158902-400510 DISTRIB/EXH	1001-000000-2600-158902-400510 AIR COND.	1001-000000-2600-158902-400510 DSP. TANKS	1001-000000-2600-158905-400510 FIRE	1001-000000-2600-158906-400510 FUEL-BURNING EQUIPMENT
1001-000000-2600-159300-400530 ELEVATOR	1001-000000-2600-159000-400520 PLUMBING	1001-000000-2600-159000-400520 S & E CONTROL	1001-000000-3700-508801-401811 CHAP	1001-000000-1500-102800-400230 TAX
1001-000000-2600-158306-400490 RAZING	1001-000000-2600-159400-400540 FILING FEE	1001-000000-2600-159400-400540 LOW VOLTAGE/TELECOMMUNICATIONS	1001-000000-2600-158009-400480 PENALTY	TOTAL FEES
	0.00	50.00		

THE AUTHORITY CONTAINED HEREIN MAY NOT BE VALIDLY EXERCISED UNTIL AND AFTER ALL OF THE FEES APPEARING HEREON HAVE BEEN PAID AND EVIDENCE THEREOF APPEARS IN THIS SPACE.



*Michael Braverman*  
MICHAEL BRAVERMAN  
BUILDING OFFICIAL

Please be advised that there is a presumption of lead-based paint in properties constructed prior to 1950. Protect workers and tenants by using lead-safe work practices found in the Code of Maryland Regulations Section 26.02.07.

THE AUTHORITY CONTAINED HEREIN DOES NOT AUTHORIZE THE PERFORMANCE OF ANY WORK IN, UNDER OR OVER ANY STREET, HIGHWAY, ALLEY, SIDEWALK OR ANY OTHER PUBLIC WAY, UNLESS PERMISSION TO DO SO HAS BEEN FIRST SECURED FROM THE PROPER AUTHORITY.

**Department Of Housing And Community Development  
Division Of Construction And Building Inspection**

Property Address: 2448 N CHARLES ST Block/Lot: 3624/033

Applicant: JAY S YOO 410-465-3606  
3440 ELLICOTT CENTER DR #202 ELLICOTT CITY MD 21043

Owner/Lessee:  
Owner 2436 NORTH CHARLES STREET, LLC  
2436 NORTH CHARLES ST BALTIMORE, MD 21218  
Lessee LUCKYSEENA, INC.  
2448 N CHARLES ST BALTIMORE, MD 21218

Contractor:

**Applicant Copy**

No: **USE2017-00209**

Plan No: -

1001-000000-2600-159400-400540	Filing Fee	50.00
1001-000000-1500-102800-400230	Tax	3.00
1001-000000-2600-158009-400480	Use&Occupancy	45.00
	Total :	98.00

# Use & Occupancy Draft

THIS IS NOT A PERMIT. THIS DOCUMENT IS PROOF OF APPLICATION FOR A PERMIT. YOU MUST OBTAIN THE ACTUAL PERMIT OR CERTIFICATE OF OCCUPANCY BEFORE THE BELOW STATED WORK OR USE CAN BEGIN. FOR MORE INFORMATION CONTACT THE ONE STOP SHOP PERMIT CENTER AT 443-984-1809.

Expiration:	WORK COST:	District: 503	MINOR PRIVILEGE:
USE PORTION OF THE PREMISES, 2448 N CHARLES ST, AS A LIQUOR STORE ( PACKAGE GOODS). UNDER URP FOR CHARLES/25TH PACKAGED GOODS IS A CONDITIONAL USE			

**\*\*\*DUPLICATE\*\*\***  
PD:1/18/2017 CR:116 LOC: WOLM WS: 012  
ID:00 TR: 0038 RCT #: 00290552  
1/13/2017 4:11PM  
PERMIT #:USE2017X00209B

CO AMOUNT PAID:	\$98.00
Building Permits	\$50.00
Building Permits	\$3.00
Building Permits	\$45.00
CK	\$196.00
CHANGE	\$0.00

June 15, 2017

**Applicant(s):** Valerie Burke and Debra Guston  
The Hangar, LLC, T/a The Hangar  
6500 St. Helena Avenue 21222

**Class:** "BD7" Beer, Wine & Liquor License

Application to transfer ownership.

(a) **Applicant(s) Information:** (1) Valerie Burke was born in Baltimore, MD in March of 1972. She lives Baltimore, MD; (2) Debra Guston was born in Baltimore, MD in May of 1953. She lives in Baltimore, MD.

(b) **Ownership Breakdown:** (1) Valerie Burke (99%); and (2) Debra Guston (1%).

(c) **Purchase Price of Business:** The purchase price of the business was \$160,000. A down payment of \$6,000 was made. Balance to be paid in cash at closing.

(d) **Qualified Voters:** Marguerite Hamlin, Sheri Strausser and Jay Covelly are qualified Baltimore City voters.

(e) **Zoning:** Applicants have applied for a USE permit, for the continued use of property as a tavern.

(f) **Corporate Standing:** The Hangar, LLC is a MD LLC and as of 5/23/2017 is active and in good standing.

(g) **Posting Report:** The location was posted on 5/19/2017, and checked on 5/29/2017. This meets the 10-day rule. There are no licensed liquor establishments in the 4x4 area.

(h) **Timeline:** Last Inspection by BLLC was performed 3/16/2017. At that time, the establishment was open and operating.

(i) **Letters of Support/Opposition:** At this time the Board has no letter(s) of opposition or support.

In considering this request, under the provisions of Alcohol Beverages Article 4-210(A) the Board must consider the following factors: 1. The public need and desire for the license; 2. The number and location of existing license holders; 3. The potential effect on existing license holders of the license for which application is made; 4. The potential commonality or uniqueness of the services and products to be offered by the business of the applicant; 5. The impact of the license for which application is made on the health, safety, and welfare of the community, including issues relating to crime, traffic conditions, parking, or convenience; and 6. Any other factor that the local licensing Board considers necessary.

**Board's Decision:**

**OFFICE USE ONLY**  
 Date Filed \_\_\_\_\_  
 Posting Date: \_\_\_\_\_  
 Approved  Yes  No \_\_\_\_\_  
 Withdrawn  Yes  No \_\_\_\_\_  
 WC Information \_\_\_\_\_  
 Policy/Binder# \_\_\_\_\_

**Application for Alcoholic Beverages License**  
**Board of Liquor License Commissioners for Baltimore City**

*NEW/TRANSFER/EXPANSION/AMENDMENT(S) APPLICATION FEE - \$500.00*  
*After June 1, 2016 \$600.00 includes Hearing Fee*

**OFFICE USE ONLY**  
 Status of Zoning Verification  
 Approved: Yes  No   
 Date Sent to Zoning: \_\_\_\_\_  
 Initials: \_\_\_\_\_  
 Zoning Info: \_\_\_\_\_

INDICATE TYPE OF LICENSE APPLICATION: TRANSFER  NEW  EXPANSION OF PREMISES  AMENDMENT(S)   
 EXPLANATION OF REQUEST: Purchase CLASS TYPE: BD7  
 LICENSE AT THE LOCATION: 6500 St. Helena Ave. IF TRANSFER, PREVIOUS LOCATION: \_\_\_\_\_  
 CORPORATE/LLC/LLP/PARTNERSHIP NAME: The Hangar LLC TRADE NAME: The Hangar  
 BUSINESS PHONE NUMBER: 443-416-1780 BUSINESS CONTACT/MANAGER: Valerie Burke  
 ATTORNEY FOR THE APPLICANT: Frank Bozzer ADDRESS: 614 Bosley Ave. PHONE: 410/828-9441  
Towson, MD 21204

Part of Premises Used (Note: Floors and Areas for Storage): entire enclosed area (1st & 2nd floor)  
 Will Live Entertainment be provided?  Yes  No What Kind (Ex. DJ, Band, Etc.)? \_\_\_\_\_  
 Will Outdoor Table Service Be Provided?  Yes  No  
 Off Premise Catering of Food and Alcohol?  Yes  No BLLC Catering Application Filed?  Yes  No  
 Delivery of alcohol?  Yes  No BLLC Delivery Application Filed?  Yes  No

*Please note that as per Art. 28 § 10-202(a)(iv)(1) that an application for the issuance or transfer is not complete unless the applicant has obtained zoning approval from the City of Baltimore. Please attach Use and Occupancy Permit or letter from BMZA approving use.*

**1. Applicant A**

Valerie Burke \_\_\_\_\_  
 (Full name) (Telephone no.) E-mail (Required)  
1713 Pinewood Dr. Balto. MD 21222 \_\_\_\_\_  
 (Residence) Street City State Zip Code (period of residency in Baltimore City)  
03/1972 \_\_\_\_\_  
 (Month/Year of Birth) (Sex: Male or Female) (Place of Birth)  
Female \_\_\_\_\_  
 (Sex: Male or Female) (Place of Birth)  
 Check:  Yes  No Have you been a resident and taxpayer of the City of Baltimore for 2 years preceding this application?  
 Yes  No Are you a registered voter in the City of Baltimore?

**2. Applicant B**

REBEA GUSTON \_\_\_\_\_  
 (Full name) (Telephone no.) E-mail (Required)  
2902 Westfield Baltimore MD 21214 \_\_\_\_\_  
 (Residence) Street City State Zip Code (period of residency in Baltimore City)  
5/1/53 \_\_\_\_\_  
 (Month/Year of Birth) (Sex: Male or Female) (Place of Birth)  
M \_\_\_\_\_  
 (Sex: Male or Female) (Place of Birth)  
 Check:  Yes  No Have you been a resident and taxpayer of the City of Baltimore for 2 years preceding this application?  
 Yes  No Are you a registered voter in the City of Baltimore?

**3. Applicant C**

\_\_\_\_\_  
 (Full name) (Telephone no.) E-mail (Required)  
 \_\_\_\_\_  
 (Residence) Street City State Zip Code (period of residency in Baltimore City)  
 \_\_\_\_\_  
 (Month/Year of Birth) (Sex: Male or Female) (Place of Birth)  
 Check:  Yes  No Have you been a resident and taxpayer of the City of Baltimore for 2 years preceding this application?  
 Yes  No Are you a registered voter in the City of Baltimore?

1. Has the applicant(s) been adjudged guilty of a felony in the State of Maryland or any other?  Yes  No - If yes, indicate applicant and explain.

Applicant A  B  C

2. Has the applicant(s) been adjudged guilty of violating the laws governing the sale of any alcoholic beverage or for gambling in any State, including Maryland?  Yes  No - If yes, mark applicant and provide explanation in adjacent space provided.

Applicant A  B  C

3. State whether the applicant(s) has ever been adjudged guilty of any offense against the laws of the State of Maryland or the United States.

Yes  No - If yes, mark applicant and explain.

Applicant A  B  C

4. Has the applicant(s) ever had a license for the sale of alcoholic beverages in the State of Maryland?  Yes  No If yes, mark applicant and explain.

Applicant A  B  C

5. Has the applicant(s) ever had a liquor license suspended or revoked?  Yes  No If yes, mark applicant and explain.

Applicant A  B  C

6. Does the applicant(s) have a pecuniary interest in any other alcoholic beverage business or business for which an alcoholic beverage license has been applied for, granted, and issued?  Yes  No If yes, mark applicant and explain.

Applicant A  B  C

7. Do the spouses or children of any of the applicant(s) have a financial interest in any other alcoholic beverages license or business in Baltimore City or any other jurisdiction in the State of Maryland?  Yes  No If yes, mark applicant and explain.

Applicant A  B  C

8. Are you financially interested in any other alcoholic beverages license applied, granted or issued?  Yes  No If yes, please explain.

Applicant A  B  C

9. Is the licensed premise currently open and operating?  Yes  No If yes, please explain.

10. Do any of the applicant(s) - personally or through an entity - have any indebtedness or other financial obligations to any manufacturer, brewer, distiller, or wholesaler at the time of making this application?  Yes  No If yes, please explain. If yes, please provide information as to the applicant(s) indebted - personally or through an entity - the amount of the indebtedness, and the name of the manufacturer, brewer, distiller, or wholesaler?

Applicant A  B  C

II. Please list the following information for the Manager of the establishment to be licensed:

Name	Address	Phone	Email
owner/applicant is manager			

Applicants Applying as Business Entities - (Give name(s) and addresses - in Corporation list all officers (attach list if necessary) or in Limited Liability Company/Partnerships list all authorized persons.) Please note that all licensees MUST have a pecuniary interest in the license applied for as per Article 2B Section 10-103(b) (10)

- 1) NAME: Valerie Burke ADDRESS: 1713 Pine Wood Dr. Balto, MD 2122 TITLE: Member % OF STOCK HELD: 99% RESIDENCE: 99%
- 2) NAME: DEBRA GUSTON ADDRESS: 2902 Westfield Boro, MD 21214 TITLE: Member % OF STOCK HELD: 1% RESIDENCE: 1%
- 3) NAME: \_\_\_\_\_ ADDRESS: \_\_\_\_\_ TITLE: \_\_\_\_\_ % OF STOCK HELD: \_\_\_\_\_ RESIDENCE: \_\_\_\_\_
- 4) NAME: \_\_\_\_\_ ADDRESS: \_\_\_\_\_ TITLE: \_\_\_\_\_ % OF STOCK HELD: \_\_\_\_\_ RESIDENCE: \_\_\_\_\_

\*\*\*\*\* Attached is a list of the names and addresses of all outstanding stockholders who on the day of this application own more than 5% of the outstanding stock of the corporation and the articles of incorporation, partnership agreement or articles of organization.\*\*\*\*\*

*\*Extract from Law: If any affidavit or oath required under the provisions of this Act shall contain any false statements, the offender shall be deemed guilty of perjury. And upon indictment and conviction thereof, shall be subject to penalties provided by Law for that crime.*

CERTIFICATE OF APPLICANTS: At least one applicant whose signature appears below certifies that he/she has been a resident and taxpayer of Baltimore City, Maryland for at least two years preceding the filing of this application. Each of said applicants hereby certifies further that if the license applied for is granted, he/she will conform to all State and County laws and regulations relating to the sale of alcoholic beverages, as well as to the rules and regulations of the Board of License Commissioners for Baltimore City, and hereby grants permission to the State Comptroller, his duly authorized deputies, inspectors and clerks, The Board of License Commissioners for Baltimore City, its duly authorized agents and employees, and any peace officer of Baltimore City or the State of Maryland to inspect and search at any and all hours, without warrant, the premises and any and all parts thereof upon and in which said business is to be conducted.

Valerie D. Burke Signature of Applicant A      Debra S. Guston Signature of Applicant B      \_\_\_\_\_ Signature of Applicant C

State of Maryland: Baltimore County ss  
 THIS CERTIFIES, THAT ON THE 14th OF JANUARY, 2017  
 before the subscriber a notary public of the State of Maryland, personally appeared  
Valerie Burke & Debra Guston  
 The applicant(s) makes in the foregoing application, and made oath in due form of law that the statement therein are true to the best of (his, her, their) knowledge and belief.

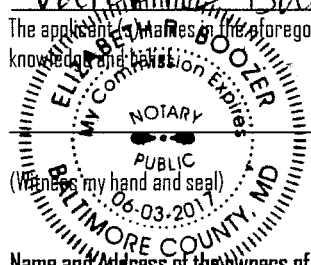

Elizabeth Bozler  
 Notary Public

Name and Address of the owners of the premise/landlord: Applicant A-B Phone Number: [REDACTED]

STATEMENT OF OWNER OF PREMISES REQUIRED IN CONNECTION WITH ALCOHOLIC BEVERAGES LAW OF MARYLAND  
 (I, WE) Valerie Burke & Debra Guston HEREBY CERTIFY, That (I am, we are) the owner(s) of the property located at 1950 St. Helena, Baltimore, City with a Zip Code of 21222, which is named in the present application made to Board of Liquor License Commissioners of Baltimore City under the Alcoholic Beverage Laws of Maryland and assent to the granting of the license applied for, and hereby authorize the State Comptroller, his duly authorized deputies, inspectors and clerks, the Board of Liquor License Commissioners of Baltimore City, its duly authorized agents

and employees, and any peace officer of the City of Baltimore and State of Maryland, to inspect and search, without warrant, the premises upon which the business is to be conducted, and any and all parts of the building in which said business is to be conducted, at any and all hours.

(Witness my, our) hand(s) and seal(s) this 19<sup>th</sup> day of Jan in the year of 2017

WITNESS: 1 Valerie D Burke  
 STATE OF MARYLAND Valerie Burke, owner

THIS CERTIFIES, THAT ON 19<sup>th</sup> day of JAN.  
 Before the subscriber, Notary Public of the State of Maryland, personally appeared Valerie Burke

and acknowledge the execution of the foregoing statement to be my own act.  
 (Witness my hand and seal) Elizabeth Boger  
 Notary Public

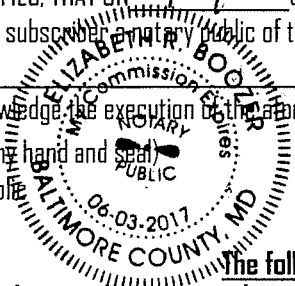

The following certificates must be signed by at least 3 persons.

We, the undersigned citizens, real estate owners and registered voters in the City of Baltimore in which the business covered by the present application is to be conducted, certify that the qualifying applicant(s) is/are personally known to us and has been a resident or a taxpayer of Baltimore City and a resident of the State of Maryland for 2 years preceding this application.

Names	Address	Signature	DOB (Month/Year)	Length of time Acquainted with the Applicant(s)
ROBERT F. GUSTON Sr.	2900 WESTFIELD AVE BALTO. MD 21214	<i>Robert F. Guston Sr.</i>	07-1951	40 yrs.
DEBRA S. GUSTON	2902 WESTFIELD AVE BALTO. MD 21214	<i>Debra S. Guston</i>	05-1953	20 yrs.
JAY COVILLY	3225 WOODHOMER BALTO, MD 21234	<i>Jay Covilly</i>	[REDACTED]	10 yrs
WILLIAM BURKE	2902 Westfield BALTO MD 21214	<i>William Burke</i>	5/1967	18 yr

Board of Liquor License Commissioners for the City of Baltimore,  
 231 East Baltimore Street, 6<sup>th</sup> Floor, Baltimore, Maryland 21202  
 Phone: 410-396-4377 Fax: 410-396-4382

Please note that this is a public document and upon request will be provided to the general members of the public.

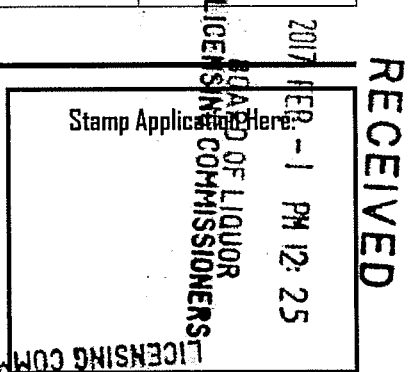

**\*Please present/draw a Floor Plan/Rendering of the Licensed Premises here. If you have a professionally drafted rendering, please attach it to the application.**



and employees, and any peace officer of the City of Baltimore and State of Maryland, to inspect and search, without warrant, the premises upon which the business is to be conducted, and any and all parts of the building in which said business is to be conducted, at any and all hours.

(Witness (my, our) hand(s) and seal(s) this \_\_\_\_\_ day of \_\_\_\_\_ in the year of \_\_\_\_\_)

WITNESS: \_\_\_\_\_

STATE OF MARYLAND

THIS CERTIFIES, THAT ON \_\_\_\_\_ day of \_\_\_\_\_

Before the subscriber a notary public of the State of Maryland, personally appeared \_\_\_\_\_

and acknowledge the execution of the foregoing statement to be \_\_\_\_\_ act.

(Witness my hand and seal)

Notary Public \_\_\_\_\_

**The following certificates must be signed by at least 3 persons.**

We, the undersigned citizens, real estate owners and registered voters in the City of Baltimore in which the business covered by the present application is to be conducted, certify that the qualifying applicant(s) is/are personally known to us and has been a resident or a taxpayer of Baltimore City and a resident of the State of Maryland for 2 years preceding this application.

Names	Address	Signature	DOB (Month/Year)	Length of time Acquainted with the Applicant(s)
MARGUERITE HANLIN	2611 Roselawn Ave	Marguerite Hanlin	11/10/61	6 yrs
Sheri Strauss	3119 Woodhome Ave <sup>M</sup>	Sheri Strauss	5/10/69	7 yrs

Board of Liquor License Commissioners for the City of Baltimore,  
231 East Baltimore Street, 6<sup>th</sup> Floor, Baltimore, Maryland 21202  
Phone: 410-396-4377 Fax: 410-396-4382

Stamp Application Here:

Please note that this is a public document and upon request will be provided to the general members of the public.

**\*Please present/draw a Floor Plan/Rendering of the Licensed Premises here. If you have a professionally drafted rendering, please attach it to the application.\***

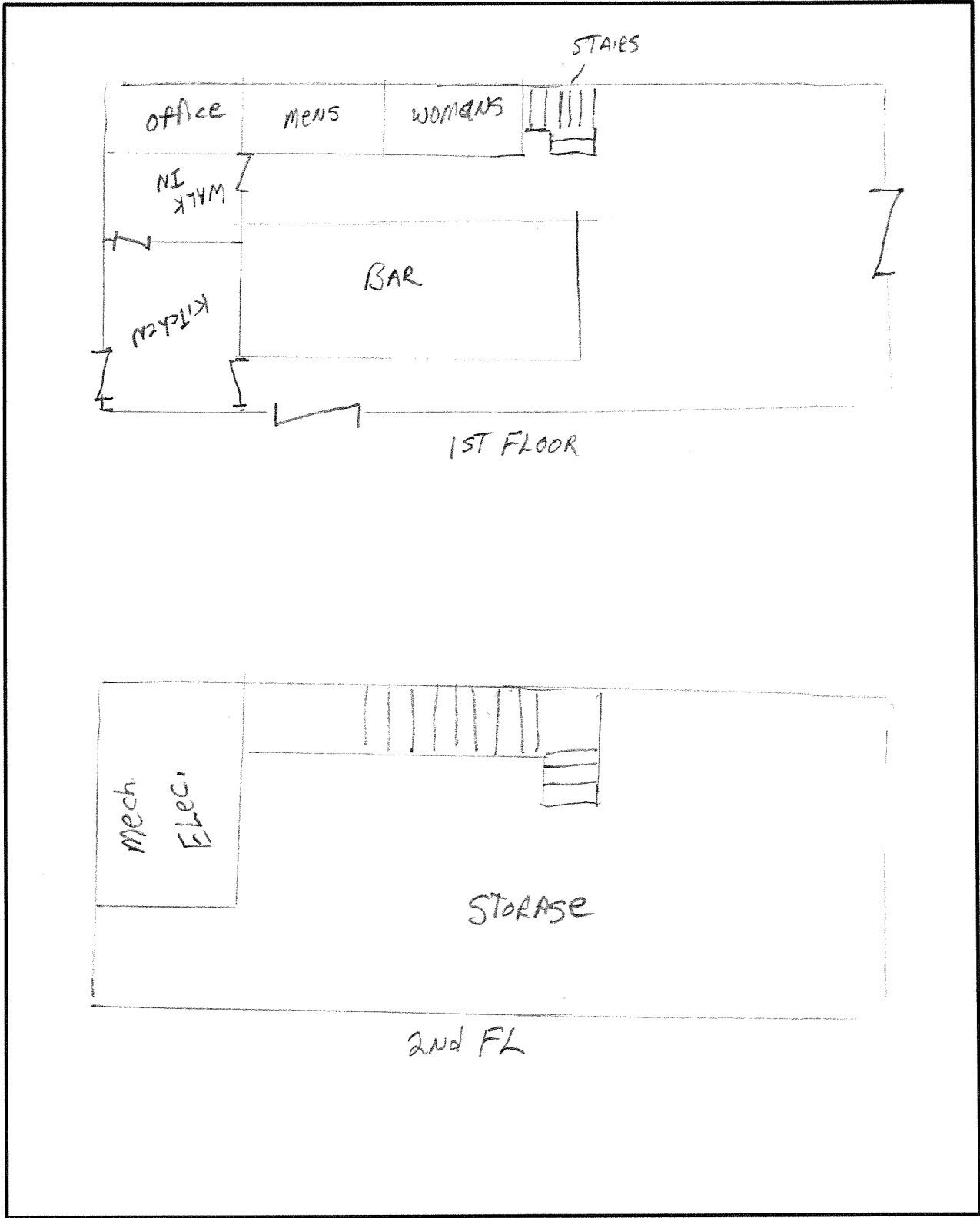



## Liquor Board System

Version 1.0

Annual-Renewal ▾ | License-Transfer ▾ | One-Day ▾ | Add New License ▾ | Query ▾ | Help ▾

### License Detail

#### License Info

License Num: **LBD7 414**      Cert Num: **1183**      Fee: **\$1,320.00**      Status: **Renewed**  
 License Date: 5/1/2016      License Year: 2016  
 CR Number: 02109781  
 Payment Date: 04-29-16

2015 - 2016 TPP Paid   
 2016 Trader's License

### Add Adult Entertainment License

#### Location

Corp Name: N/A  
 Trade Name: **RAY'S TAVERN**  
 Zone Code: 10  
 Phone: 443-570-2909

Block Num: 6500      Street: ST. HELENA AVENUE  
 City: BALTIMORE      State: MD      Zip: 21222

CR Number: 02109781

Portion of Business Used:  
 RES. N.C.U. APPR. ENTIRE BUILDING FOR BUSINESS - NO DWELLING

Restriction:  
 THERE IS TO BE NO SEPARATE PACKAGE GOODS STORE OR DEPARTMENT. ALL PACKAGE GOODS TO BE SOLD OVER THE BAR.

#### License Owners

First Name	Last Name	Street	City	State	Zip	Action	Change Owner
MERRI	TOULAS P.R	1 DELLWOOD CT.	COCKEYSVILLE	MD	21030	<input type="button" value="Edit"/>	<input type="button" value="Remove Owner"/>

#### Comments

Date	Comment	Action

07/12/2016	7/6/2016- A letter was received from Merri Toulas-PR (personal Rep. for the estate of Raymond Bondura) requesting to change the home address we have on file 1 Dellwood Ct. Cockeysville, MD 21030	Delete
05/06/2015	Alcohol Awarness exprise on 3/25/2019 ( Dawn E Davis)	Delete
05/05/2010	4/29/10 \$500 FINE COMPLETED #73549	Delete
05/05/2010	3/30/10 \$500 FINE PARTIAL PAYMENT PAID #71884	Delete
02/27/2009	02/26/09 RECONSIDERATION BY BOARD FINE REDUCED TO \$1000.GRANTED UNTIL 3/21/09.FINE \$1000	Delete
02/24/2009	02/19/09 Public Hearing re: Violation of rules 4.01(a) and 3.03(c).DECISION: RULE 4.01(a) (12/5/08) GUILTY \$500/SUSPENDED \$250(1/9/09) GUILTY \$2250/SUSPENDED \$500 AND RULE 3.03 (c) GUILTY SUSPENDED ALL.WAIVED ADM.FEE AND MUST BE PAID BY 4/20/09.FINE \$2000	Delete
01/21/2009	01/15/09 Public Hearing re: Violation of rule 4.01(a),303(a).4.18 DECISION: CASE POSTPONED	Delete

[ Print History (Print Card) ]

License num: LBD7 414

Address: 6500 ST. HELENA AVENUE

Trade Name: RAY'S TAVERN

Comment:

[ Add Comment ]

**Hold Info**

Powered by:



Maryland Department of Assessments and Taxation Business Services (w1)

[Search Help](#)

Entity Name: THE HANGAR, LLC

Department ID: W17736869

General Information      Amendments      Personal Property      Certificate of Status

Principal Office (Current):	6500 ST. HELENA BALTIMORE, MD 21222
Resident Agent (Current):	VALERIE BURKE 6500 ST. HELENA BALTIMORE, MD 21222
Status:	ACTIVE
Good Standing:	Yes
Business Code:	Other What does it mean when a business is not in good standing or forfeited?
Date of Formation or Registration:	01/19/2017
State of Formation:	MD
Stock/Nonstock:	N/A
Close/Not Close:	Unknown

PROPOSED LOCATION: 6500 Saint Helena Ave

### MAP SUMMARY (RECAPITULATION)

TOTAL ESTABLISHMENTS IN MAP AREA 0

"A" BEER & WINE \_\_\_\_\_

"B" BEER & WINE \_\_\_\_\_

"C" BEER & WINE \_\_\_\_\_

"D" BEER & WINE \_\_\_\_\_

"A" BEER, WINE & LIQUOR \_\_\_\_\_

"A-2" BEER, WINE & LIQUOR \_\_\_\_\_

"B" BEER, WINE & LIQUOR \_\_\_\_\_

"C" BEER, WINE & LIQUOR \_\_\_\_\_

"D" BEER, WINE & LIQUOR \_\_\_\_\_

"BD7" BEER, WINE & LIQUOR \_\_\_\_\_

ARENA \_\_\_\_\_

HOTEL/MOTEL \_\_\_\_\_

RACING \_\_\_\_\_

PREPARED BY: Andy Perez DATE: 6/1/17

# 6500 Saint Helena Avenue

Proposed Location

6500 St Helena Ave

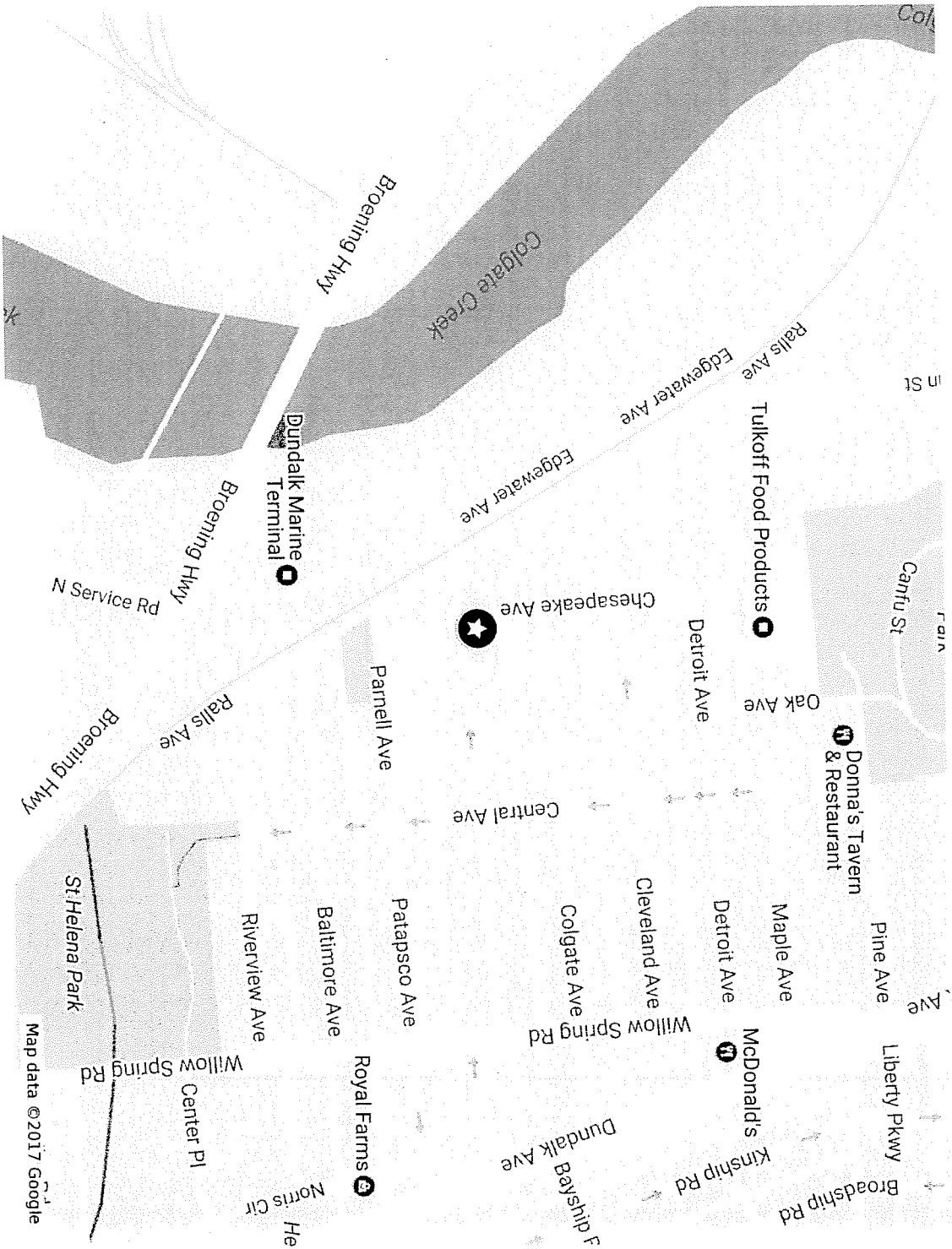

### Board of Liquor License Commissioners

For Baltimore City  
231 E. Baltimore Street, 6<sup>th</sup> Floor  
Baltimore, Maryland, 21202-3258

## INSPECTORS REPORT - TRANSFERS/NEW APPLICATIONS

Licensee Information (Trade Name):	The Hangar
Corporation Name:	The Hangar LLC
Location Address:	6500 Saint Helena Ave
License Type:	Class "BD7" Beer, Wine and Liquor
Is the establishment open and operating in a safe and sanitary manner? (If not open, not in comments - CLOSED or NOT OPERATING)	No
Is the location within 300 feet of Church and/or School?	No
Date Posted?	5/19/2017
Date Removed?	
Are there any other licensed establishments within a two block radius?	No

**Other licensed locations - Describe/Note:**

No other Liquor Licensed establishment within 2-3 block radius.

**Comments and Follow-up Items(s) (please note any issues or concerns about the location):**

Application filed for transfer of ownership.

**Insert Photo of Sign and location:**

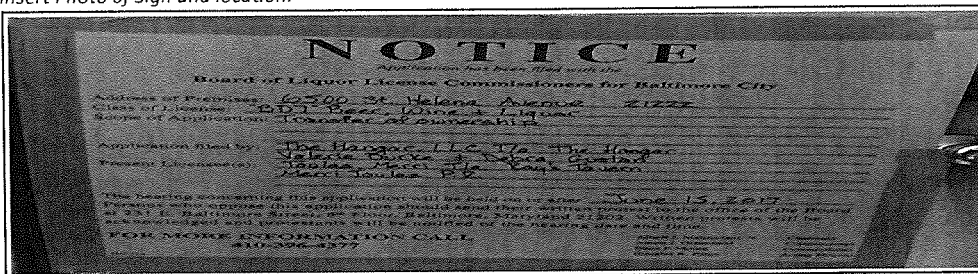



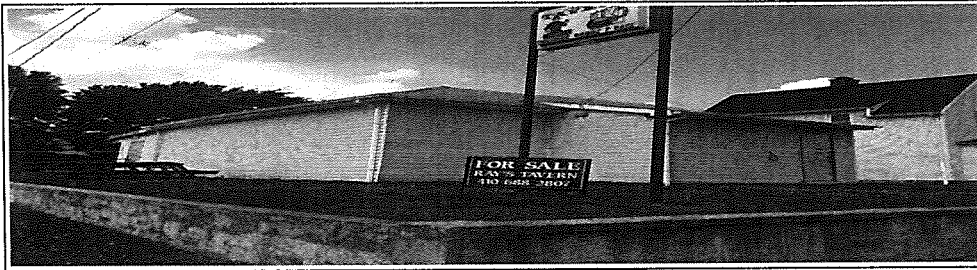
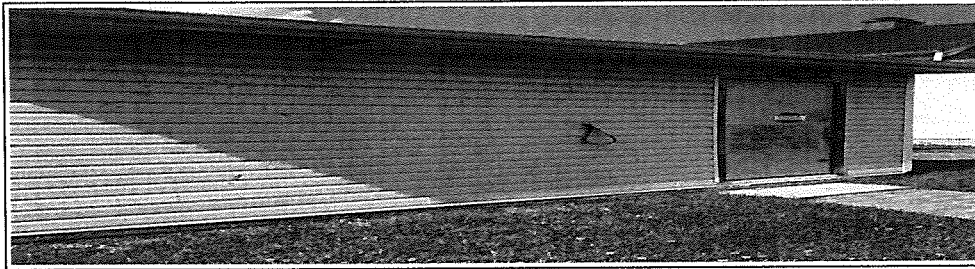

Inspector Name	Date and Time	
<input type="text" value="i:\0#w\baltimore\andy.perez"/>	<input type="text" value="5/25/2017"/>	<input type="text" value="11:53:14 AM"/>
Name of Licensee (if present)		
<input type="text"/>		

# Board of Liquor License Commissioners

For Baltimore City  
231 E. Baltimore Street, 6<sup>th</sup> Floor  
Baltimore, Maryland, 21202-3258

## POSTING SIGNS REPORT

Applicant(s) Name:	Valiere Burke & Debra Guston
Address of Premises:	6500 St. Helena Ave
Inspector:	i:0#.w baltimore\andy.perez
Date Posted:	5/19/2017
Time Posted:	3:44 PM
Date Rechecked:	5/29/2017
Time Rechecked:	5:00 PM
Manager or Owner when sign posted:	

Summary on location of sign posted:

Sign posted on front door.

Summary on location of sign rechecked:

sign remained as posted for the required 10 days period.

Insert Photo of Sign and location:



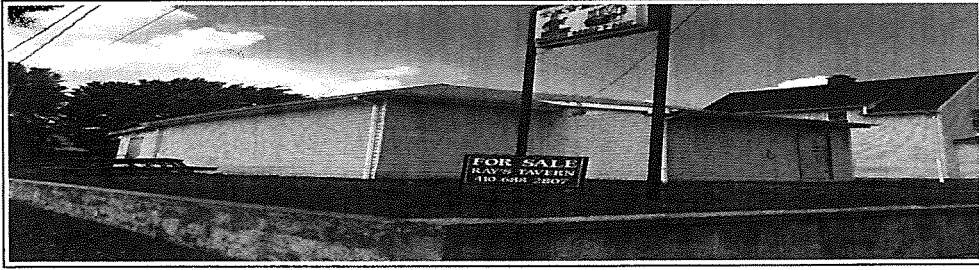

# BLLC Routine Inspection

## Licensee Information

Address: 6500 ST. HELENA AVENUE 21222

Trade Name: RAY'S TAVERN

Corporation Name: N/A

Type of License: Class "BD7" Beer, Wine and Liquor

Date/Time of Inspection: 3/16/2017

3:53:02 PM

Manager/Licensee: Merri Toulas

## Open/Closed Status

Open/Closed: Open

Closed Date:

## External Appearance

Clean and Free of Debris: Satisfactory

## Internal Appearance

Location of Bar: Front

Shape of Bar:

Condition of Bar Area/Floors: Satisfactory

Hot Water: Yes

Disinfectant Solution: Yes

Three Compartment/Washer: Yes

## Package Goods/BD7 Checklist

Bulletproof Partitioning: N/A

Separate Pkg. Goods Dept.: N/A

Separate Pkg. Goods Store: N/A

Bar/Tavern Open and Operating: Yes

Selling Household/Grocery: N/A

Dining Area

Capacity:

Location of Dining Area:

Condition of Dining Area/Floors: N/A

Sanitation: N/A

Menu: N/A

Business Records

Traders License: Yes

Alcohol Awareness Certification Date Issued: 3/25/2015

Employee Records: Yes

Alcohol Beverage Information Invoice Numbers and Date: w-2261513 3/10/2017

Kitchen

Inspector Comments: NA

Restroom

Inspector Comments: Satisfactory Rear

Public Safety

Exits Marked, Unobstructed: Yes

Fire Capacity:

Outdoor Seating Capacity: 0

Adult Entertainment - If Applicable

License is Valid: N/A

Dancers Present 18 and older: N/A

Cleanliness of Dressing Room: N/A

Ancillary Services

Live Entertainment (Describe): None

Outdoor Table Service N/A

Violations

Violation Issued: No

Violations Noted: None

Wrap-Up

Instructions Given to Licensee: None

Inspector's Comments: All records in order  
Bar was open and operating when inspector arrived.  
Health expires 6/30/2017

Photo Taken:

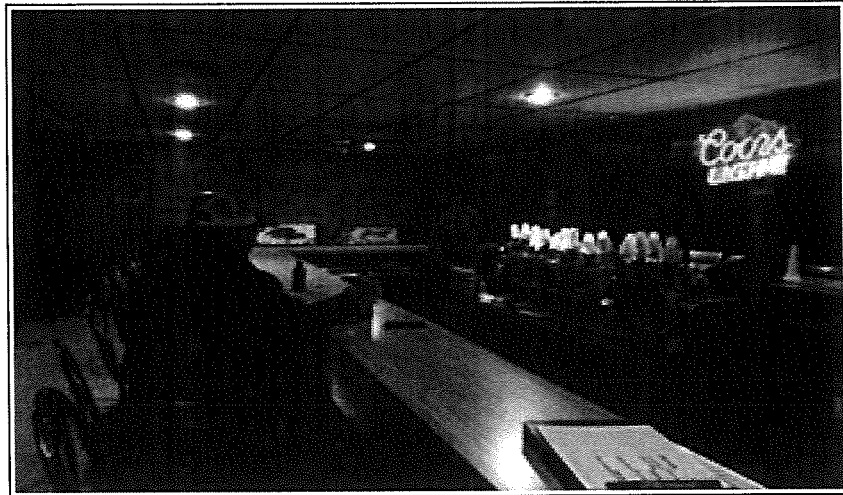

Owner Email:

Submitted by Inspector

6500 ST. HELENA AVE. 26 6987  
R-6 1 40/41

~~3/26/75 APPEAL TO B.M.Z.A. (PAPERS LOST)~~  
4/23/75 APPEAL TO B.M.Z.A.  
5/20/75 Summary L  
6/3/75 B.M.Z.A. 264-75 approved conditionally may allow for increase of floor area by 25% & time no objection from attorney met to exceed limit.

LOCATION	<u>6500 St Helena Ave.</u>		
Owner	<u>Frank W. Kaahn</u>	<u>R-6</u>	
Proposed	<u>ERECT 1st rear Addition to Tavern Use</u>		
Reviewed	<u>By Buildings Engineer 4/9/47</u>		
Violation	Use <input checked="" type="checkbox"/>	Height	Area
Appeal No	<u>348-47</u>	Date of B.Z.A. action	<u>4/27/47</u>
Decision of B.Z.A.	<u>APPROVED</u>		
Permit No.	<u>53291</u>	Issued	<u>4/25/47</u>

26 6987  
1 40/41



June 15, 2017

**Licensee(s):** Jayne Vieth  
Sole Proprietorship T/a Henninger's Tavern  
1810-12 Bank Street 21231

**Class:** "D" Beer, Wine & Liquor License

Request to add outdoor table service.

(a) **Licensee(s) Information:** (1) Jayne Vieth was born in Pennsylvania in July of 1959. She lives in Baltimore, MD.

(b) **Ownership Breakdown:** (1) Jayne Vieth (100%).

(c) **Purchase Price of Business:** N/A

(d) **Qualified Voters:** N/A

(e) **Zoning:** The licensee have filed an application for a use permit to use the premises as a restaurant with outdoor table service.

(f) **Corporate Standing:** N/A

(g) **Posting Report:** The location was posted on 5/26/2017, and checked on 6/6/2017. This meets the 10-day rule. There are 14 licensed liquor establishments in the 4x4 area: "A" BWL - 1; "B" BWL - 1; "C" BWL - 1; "D" BWL - 5; and "BD7" - 6.

(h) **Timeline:** Last Inspection of establishment was performed on 2/8/2017. At that time, the establishment was open and operating.

(i) **Letters of Support/Opposition:** At this time the Board has received one letter of support.

In considering this request, under the provisions of Article 2B, Section 10-202(a), the Board must consider the following factors: 1. The public need and desire for the license; 2. The number and location of existing licensees and the potential effect on existing licensees of the license applied for; 3. The potential commonality or uniqueness of the services and products to be offered by the applicant's business; 4. The impact on the general health, safety, and welfare of the community, including issues relating to crime, traffic condition. 5. Any other necessary factors as determined by the Board.

**Board's Decision:**

# Application for Alcoholic Beverages License Board of Liquor License Commissioners for Baltimore City

NEW/TRANSFER/EXPANSION/AMENDMENT(S) APPLICATION FEE - \$600.00

\*\*\*Place cursor on the field to enter text Do Not tab.

INDICATE TYPE OF LICENSE APPLICATION: TRANSFER  NEW  EXPANSION OF PREMISES  AMENDMENT(S)

EXPLANATION OF REQUEST: out Door Seating CLASS TYPE: D

IF NEW LICENSE REQUEST, THEN ADDRESS OF PROPOSED LOCATION: \_\_\_\_\_

IF TRANSFER OF OWNERSHIP ONLY, THEN ADDRESS OF CURRENT LICENSE: \_\_\_\_\_

IF TRANSFER OF OWNERSHIP AND LOCATION, THEN CURRENT ADDRESS OF LICENSED LOCATION: \_\_\_\_\_

IF TRANSFER OF OWNERSHIP AND LOCATION, THEN ADDRESS OF PROPOSED RELOCATION: 1810-12 Bank Street 2123

CORPORATE/LLC/LLP/PARTNERSHIP NAME: Jayne Irvin Vieth TRADE NAME: Jayne Irvin Vieth

BUSINESS PHONE NUMBER: 410-342-2172 BUSINESS EMAIL ADDRESS: \_\_\_\_\_

ATTORNEY FOR THE APPLICANT: \_\_\_\_\_ ADDRESS: \_\_\_\_\_ PHONE: \_\_\_\_\_

Part of Premises Used (Note: Floors and Areas for Storage): FIRST FLOOR BUSINESS, BASEMENT STORAGE

Live Entertainment provided?  Yes  No What Kind (Ex. DJ Band, Etc.)? \_\_\_\_\_

Outdoor Table Service Provided?  Yes  No Off Premise Catering of Food and Alcohol?  Yes  No Catering Application filed with BLLC?  Yes  No

Delivery of alcohol?  Yes  No Zoning Receipt or Current Certificate of Occupancy Permit attached to Application?  Yes  No

Please note that as per Alc. Bev. Art. 8 12-1407(A)(2), an application for the issuance or transfer, is not complete unless the applicant has obtained approval and/or verification from the Baltimore Municipal Zoning Administration (BMZA)

1. Applicant A Jayne Irvin Vieth [REDACTED]

(Full name) Jayne Irvin Vieth (Telephone no.) [REDACTED] E-mail (Required) \_\_\_\_\_

(Residence) Street 1911 Bank St City Baltimore State MD Zip Code 21231 (period of residency in Baltimore City) 30 Years

(Month/Year of Birth) 7/1959 (Sex: Male or Female) Female (Place of Birth) PA

Check:  Yes  No Have you been a resident and taxpayer of the City of Baltimore for 2 years preceding this application?  
 Yes  No Are you a registered voter in the City of Baltimore?

2. Applicant B

(Full name) \_\_\_\_\_ (Telephone no.) \_\_\_\_\_ E-mail (Required) \_\_\_\_\_

(Residence) Street \_\_\_\_\_ City \_\_\_\_\_ State \_\_\_\_\_ Zip Code \_\_\_\_\_ (period of residency in Baltimore City) \_\_\_\_\_

(Month/Year of Birth) \_\_\_\_\_ (Sex: Male or Female) \_\_\_\_\_ (Place of Birth) \_\_\_\_\_

Check:  Yes  No Have you been a resident and taxpayer of the City of Baltimore for 2 years preceding this application?  
 Yes  No Are you a registered voter in the City of Baltimore?

3. Applicant C

(Full name) \_\_\_\_\_ (Telephone no.) \_\_\_\_\_ E-mail (Required) \_\_\_\_\_

(Residence) Street \_\_\_\_\_ City \_\_\_\_\_ State \_\_\_\_\_ Zip Code \_\_\_\_\_ (period of residency in Baltimore City) \_\_\_\_\_

(Month/Year of Birth) \_\_\_\_\_ (Sex: Male or Female) \_\_\_\_\_ (Place of Birth) \_\_\_\_\_

Check:  Yes  No Have you been a resident and taxpayer of the City of Baltimore for 2 years preceding this application?  
 Yes  No Are you a registered voter in the City of Baltimore?

RECEIVED  
BALTIMORE LIQUOR COMMISSIONERS  
7:22 PM 3:45

1. Has the applicant(s) been adjudged guilty of a felony in the State of Maryland or any other?  Yes  No - If yes, indicate applicant and explain.  
Applicant A  B  C

[Redacted area]

2. Has the applicant(s) been adjudged guilty of violating the laws governing the sale of any alcoholic beverage or for gambling in any State, including Maryland?  Yes  No - If yes, mark applicant and provide an explanation in adjacent space provided.  
Applicant A  B  C

[Redacted area]

3. State whether the applicant(s) has ever been adjudged guilty of any offense against the laws of the State of Maryland, any other State within the United States, or against the United States (Federal Crime)?  Yes  No - If yes, mark applicant and explain.  
Applicant A  B  C

[Redacted area]

4. Has the applicant(s) ever had a license for the sale of alcoholic beverages in the State of Maryland?  Yes  No If yes, mark applicant and explain.  
Applicant A  B  C

[Redacted area]

5. Has the applicant(s) ever had a liquor license suspended or revoked?  Yes  No If yes, mark applicant and explain.  
Applicant A  B  C

[Redacted area]

6. Does the applicant(s) have a financial interest in any other alcoholic beverage business or business for which an alcoholic beverage license has been applied for, granted, and issued?  Yes  No If yes, mark applicant and explain.  
Applicant A  B  C

[Redacted area]

7. Do the spouses or children of any of the applicant(s) have a financial interest in any other alcoholic beverages license or business in Baltimore City or any other jurisdiction in the State of Maryland?  Yes  No If yes, mark applicant and explain.  
Applicant A  B  C

[Redacted area]

8. Are you financially interested in any other alcoholic beverages license applied, granted or issued?  Yes  No If yes, please explain.  
Applicant A  B  C

[Redacted area]

9. Is the licensed premise currently open and operating?  Yes  No If no, then please explain when the establishment ceased operations.

[Redacted area]

10. Do any of the applicant(s) - personally or through an entity - have any indebtedness or other financial obligations to any manufacturer, brewer, distiller, or wholesaler at the time of making this application?  Yes  No If yes, please explain. If yes, please provide information as to the applicant(s) indebted - personally or through an entity - the amount of the indebtedness, and the name of the manufacturer, brewer, distiller, or wholesaler?

Applicant A  B  C

[Redacted area]

**II. Please list the following information for the Manager of the establishment to be licensed:**

Name	Address	Phone	Email
Kenneth VIETH	1911 BANK ST BALTIMORE MD 21231	410 253 7100	VIETH.KENNY@COMCAST

Applicants Applying as Business Entities - (Give name(s) and addresses - in Corporation list all officers (attach list if necessary) or in Limited Liability Company/Partnerships list all authorized persons.) *Please note that all licensees MUST have a FINANCIAL INTEREST in the license applied for as per Alc. Bev. Art. § 4-109 (a)(11). If necessary, please attach a list of the names and address of all outstanding stock holders who at the time of application own more than 5% of the outstanding stock of the corporation and the articles of incorporation, partnership agreement or articles of organization.*

- 1) NAME: Jayne Vieth ADDRESS: 1911 BANK ST  
BALTIMORE MD 21231 TITLE: OWNER %OF STOCK HELD: N/A
- 2) NAME: \_\_\_\_\_ ADDRESS: \_\_\_\_\_ TITLE: \_\_\_\_\_ %OF STOCK HELD: \_\_\_\_\_
- 3) NAME: \_\_\_\_\_ ADDRESS: \_\_\_\_\_ TITLE: \_\_\_\_\_ %OF STOCK HELD: \_\_\_\_\_
- 4) NAME: \_\_\_\_\_ ADDRESS: \_\_\_\_\_ TITLE: \_\_\_\_\_ %OF STOCK HELD: \_\_\_\_\_

*\*Extract from Law: If any affidavit or oath required under the provisions of this Act shall contain any false statements, the offender shall be deemed guilty of perjury. And upon indictment and conviction thereof, shall be subject to penalties provided by Law for that crime.*

**CERTIFICATE OF APPLICANTS:** At least one applicant whose signature appears below certifies that he/she has been a resident and taxpayer of Baltimore City, Maryland for at least two years preceding the filing of this application. Each of said applicants hereby certifies further that if the license applied for is granted, he/she will conform to all State and County laws and regulations relating to the sale of alcoholic beverages, as well as to the rules and regulations of the Board of License Commissioners for Baltimore City, and hereby grants permission to the State Comptroller, his duly authorized deputies, inspectors and clerks, The Board of License Commissioners for Baltimore City, its duly authorized agents and employees, and any peace officer of Baltimore City or the State of Maryland to inspect and search at any and all hours, without warrant, the premises and any and all parts thereof upon and in which said business is to be conducted.

Jayne Vieth  
Signature of Applicant A

I hereby certify that on the 22 day of MAY, 2017, before me, the subscriber, a notary public of the State of MARYLAND in and for BALTIMORE, personally appeared JAYNE IRVIN VIETH the applicant(s) named in this renewal application made oath in due form of law that the matter and facts contained in said application are true and correct. As witness, my hand and notarial seal.

Signature: Ryan J. Frederick [Notary Seal] My Commission expires MARCH 22, 2021

Printed Name: RYAN J FREDERICK

**RYAN JOSEPH FREDERICK  
NOTARY PUBLIC  
BALTIMORE COUNTY  
MARYLAND  
My Commission Expires March 22, 2021**

\_\_\_\_\_  
Signature of Applicant B

I hereby certify that on the \_\_\_\_\_ day of \_\_\_\_\_, 20\_\_\_\_, before me, the subscriber, a notary public of the State of \_\_\_\_\_ in and for \_\_\_\_\_, personally appeared \_\_\_\_\_ the applicant(s) named in this renewal application made oath in due form of law that the matter and facts contained in said application are true and correct. As witness, my hand and notarial seal.

Signature: \_\_\_\_\_ [Notary Seal] My Commission expires \_\_\_\_\_

Printed Name: \_\_\_\_\_

\_\_\_\_\_  
Signature of Applicant C

I hereby certify that on the \_\_\_\_\_ day of \_\_\_\_\_, 20\_\_\_\_, before me, the subscriber, a notary public of the State of \_\_\_\_\_ in and for \_\_\_\_\_, personally appeared \_\_\_\_\_ the applicant(s) named in this renewal application made oath in due form of law that the matter and facts contained in said application are true and correct. As witness, my hand and notarial seal.

Signature: \_\_\_\_\_ [Notary Seal] My Commission expires \_\_\_\_\_

Printed Name: \_\_\_\_\_

Name and Address of the owners of the premise/landlord: Jayne + Kenneth Vieth Phone Number: [REDACTED]  
1911 Bank St. Balt Md 21231

**STATEMENT OF OWNER OF PREMISES REQUIRED IN CONNECTION WITH ALCOHOLIC BEVERAGES LAW OF MARYLAND**

(I, WE) Jayne + Kenneth VIETH HEREBY  
 CERTIFY, That (I am, we are) the owner(s) of the property located at 1812 Bank St. BALT MD  
 Baltimore, City with a Zip Code of 21231, which is named in the present application made to Board of Liquor License  
 Commissioners of Baltimore City under the Alcoholic Beverage Laws of Maryland and assent to the granting of the license applied for,  
 and hereby authorize the State Comptroller, his duly authorized deputies, inspectors and clerks, the Board of Liquor License  
 Commissioners of Baltimore City, its duly authorized agents and employees, and any peace officer of the City of Baltimore and State  
 of Maryland, to inspect and search, without warrant, the premises upon which the business is to be conducted, and any and all parts  
 of the building in which said business is to be conducted, at any and all hours.

I hereby certify that on the 22 day of MAY, 2017, before me, the subscriber, a notary public of the State of MARYLAND, in and  
 for BALTIMORE, personally appeared JAYNE IRVIN VIETH the  
 applicant(s) named in this renewal application made oath in due form of law that the matter and facts contained in said application are true and correct.

As witness, my hand and notarial seal.

Signature: Ryan J. Frederick

[Notary Seal] My Commission expires MARCH 22, 2021

Printed Name: RYAN J. FREDERICK

**The following certificates must be signed by at least 3 persons.**

**We, the undersigned citizens, real estate owners and registered voters in the City of Baltimore in which the business covered by the present application is to be conducted, certify that the qualifying applicant(s) is/are personally known to us and has been a resident or a taxpayer of Baltimore City and a resident of the State of Maryland for 2 years preceding this application.**

Names	Address	Signature	DOB (Month/Year)	Length of time Acquainted with the Applicant(s)
Cassandra Kasparian	315 S. Durham St	<i>Cassandra M. Kasparian</i>	06/01/1977	5 years
Zorana Grdjic	327 S. Ann St.	<i>Zorana Grdjic</i>	2/01/71	20 yrs
Jim Shetler	330 S. Patterson Park	<i>Jim Shetler</i>	3/01/62	25 yrs
Kristin Corsi	1816 Bank St.	<i>Kristin Corsi</i>	10/01/65	10 yrs.
DAN HARRISON	1903 BANK ST	<i>Dan Harrison</i>	4/01/54	30 yrs

Board of Liquor License Commissioners for the City of Baltimore,  
 231 East Baltimore Street, 6<sup>th</sup> Floor, Baltimore, Maryland 21202  
 Phone: 410-396-4377 Fax: 410-396-4382

Please note that this is a public document and upon request will be provided to the general members of the public.

RYAN JOSEPH FREDERICK  
 NOTARY PUBLIC  
 BALTIMORE COUNTY  
 MARYLAND  
 My Commission Expires March 22, 2021

**\*Please present/draw a Floor Plan/Rendering of the Licensed Premises here. If you have a professionally drafted rendering, please attach it to the application.\***

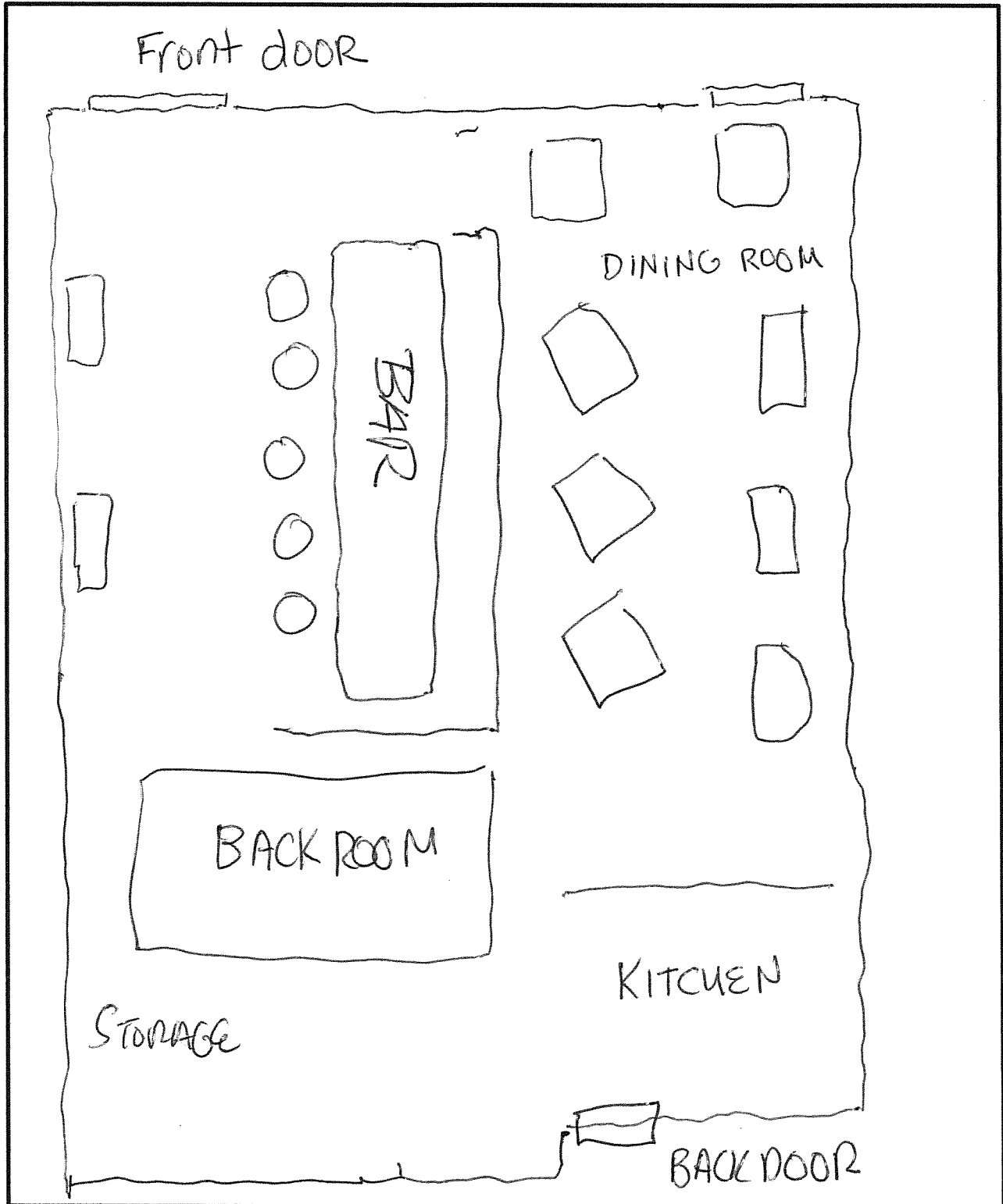

Alley

Trash

1808 Bank St.  
Michael Ruetz  
Amy Ruetz  
1808 Bank St.  
Baltimore, MD 21231

1814 Bank St.  
Marla Streb  
1814 Bank St.  
Baltimore, MD  
21231

### Henninger's Tavern 1810 Bank St.

Kenneth J. Vieth  
Jayne B. Vieth  
1911 Bank St.  
Baltimore, MD 21231  
3 story "double-wide" masonry  
& wood framed building  
R-8

BLOCK / LOT  
1763 024

300 Block S. Durham St.

67'-0" Lot Depth

Sallyport/walkway

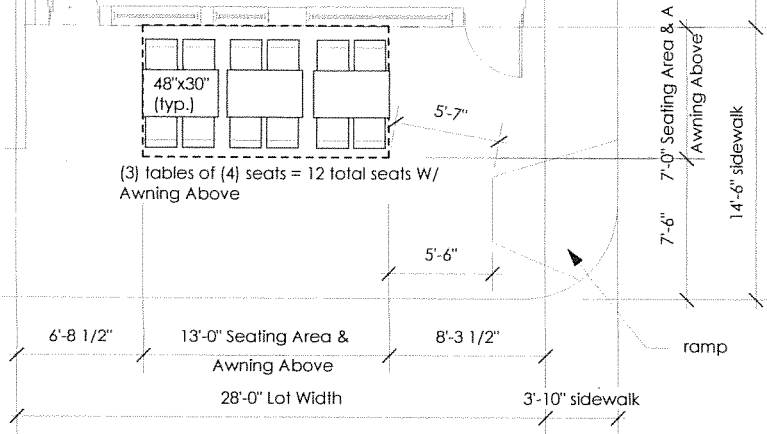

1800 Block Bank St.

trace  
ARCHITECTS

Site Plan  
scale: 1/8" = 1'-0"

CLIENT: Henninger's Tavern

PROJECT: 1810 Bank St.  
Baltimore, MD 21231

DATE: 09.16.2010

C-1  
1 of 1



## Liquor Board System

Version 1.0

Annual-Renewal ▾ | License-Transfer ▾ | One-Day ▾ | Add New License ▾ | Query ▾ | Help ▾

### License Detail

#### License Info

License Num: LD 040                      Cert Num: 0895                      Fee: \$825.00                      Status: Renewed  
 License Date: 5/1/2017                      License Year: 2017  
 CR Number: 04758165  
 Payment Date: 04-27-17

2016 - 2017 TPP Paid   
 2017 Trader's License

[Click to Start License Renewal](#)

### Add Adult Entertainment License

#### Location

Corp Name: N/A  
 Trade Name: HENNINGER'S TAVERN  
 Zone Code: 23  
 Phone: 410-342-2172

Block Num: 1810-12                      Street: BANK STREET  
 City: BALTIMORE                      State: MD                      Zip: 21231

CR Number: 04758165

Portion of Business Used:  
 FIRST FLOOR FOR BUSINESS & BASEMENT FOR STORAGE

Restriction:

#### License Owners

First Name	Last Name	Street	City	State	Zip	Action	Change Owner
JAYNE B.	VIETH	1911 BANK STREET	BALTIMORE	MD	21231	<input type="button" value="Edit"/>	<input type="button" value="Remove Owner"/>

#### Comments

Date	Comment	Action



11/15/2016	Mailed letter of recognition for underage drinking compliance check on 10/28/16	Delete
03/21/2016	RELEASED STATE HOLD.... /sb	Delete
01/19/2016	State of MD Tax Hold, letter sent... /sb	Delete
01/30/2015	State of MD Tax Hold, letter sent to merchant on January 23, 2015.	Delete

[ Print History (Print Card) ]

License num: LD 040                      Address: 1810-12 BANK STREET  
 Trade Name: HENNINGER'S TAVERN

Comment:

[ Add Comment ]

Hold Info

Powered by:



PROPOSED LOCATION: 1810 BANK STREET

## MAP SUMMARY (RECAPITULATION)

TOTAL ESTABLISHMENTS IN MAP AREA 14

"A" BEER & WINE \_\_\_\_\_

"B" BEER & WINE \_\_\_\_\_

"C" BEER & WINE \_\_\_\_\_

"D" BEER & WINE \_\_\_\_\_

"A" BEER, WINE & LIQUOR 1 \_\_\_\_\_

"A-2" BEER, WINE & LIQUOR \_\_\_\_\_

"B" BEER, WINE & LIQUOR 1 \_\_\_\_\_

"C" BEER, WINE & LIQUOR 1 \_\_\_\_\_

"D" BEER, WINE & LIQUOR 5 \_\_\_\_\_

"BD7" BEER, WINE & LIQUOR 6 \_\_\_\_\_

ARENA \_\_\_\_\_

HOTEL/MOTEL \_\_\_\_\_

RACING \_\_\_\_\_

PREPARED BY: J. RAY DATE: MAY 26, 2017

# 1810 Bank Street

## LICENSED ESTABLISHMENTS

- ★ Henninger's Tavern LC
- 📍 SPIRITS TAVERN LC
- 📍 Tela Mares Restaurant LE
- 📍 HONEY'S LOUNGE BD7
- 📍 RYDER'S BD7
- 📍 MARY'S TAVERN LD
- 📍 POLISH NATIONAL ALLIANCE COUNCIL 21 LC
- 📍 BRASS MONKEY SALOON BD7
- 📍 SUNLIGHT LOUNGE LD
- 📍 PORT CITY TAVERN BD7
- 📍 BENDERS BD7
- 📍 SWEET CAROLINA LA
- 📍 207 S Broadway LC
- 📍 SHERRY'S PLACE BD7

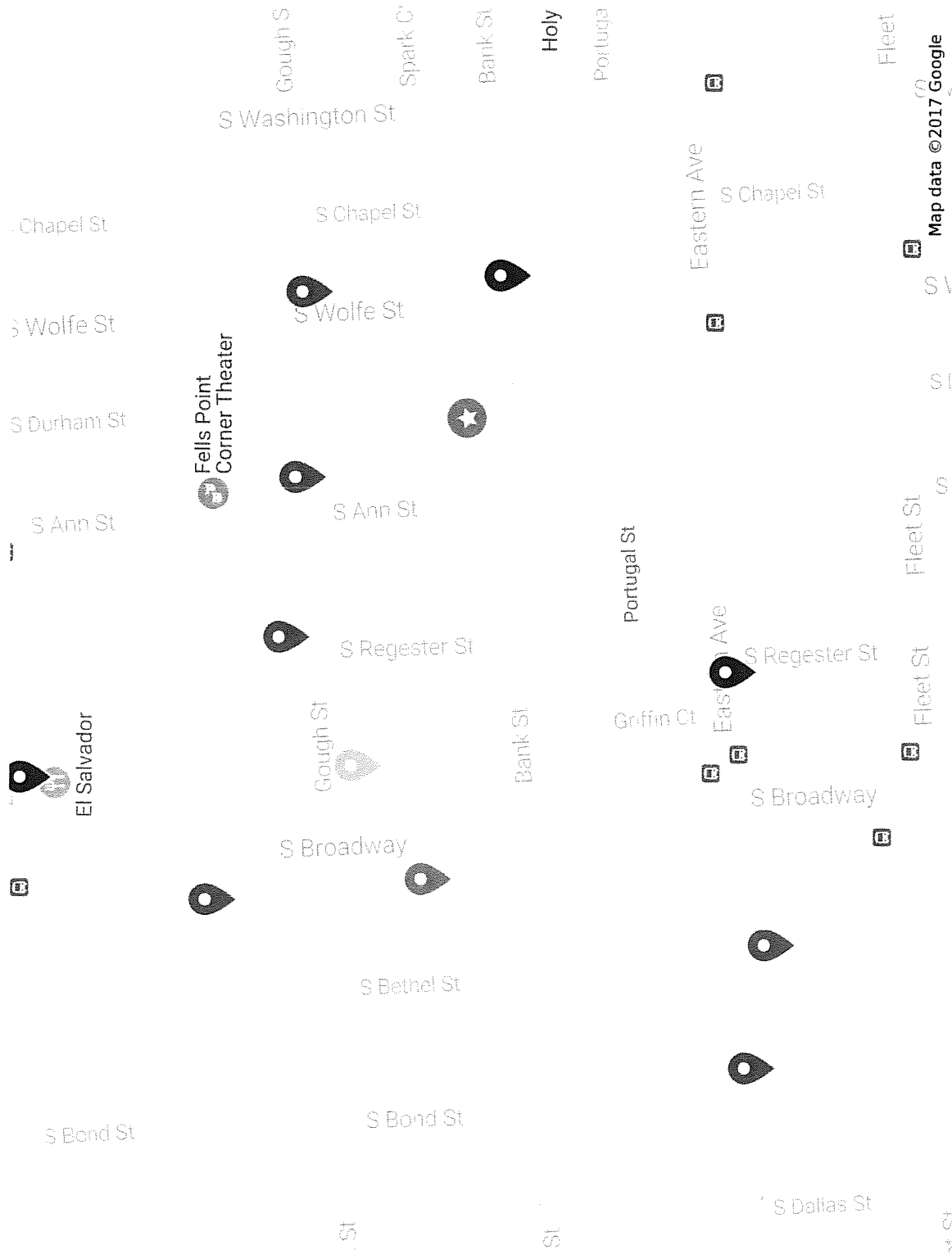

**Board of Liquor License Commissioners**

For Baltimore City  
 231 E. Baltimore Street, 6<sup>th</sup> Floor  
 Baltimore, Maryland, 21202-3258

**INSPECTORS REPORT - TRANSFERS/NEW APPLICATIONS**

<i>Licensee Information (Trade Name):</i>	Henninger's Tavern
<i>Corporation Name:</i>	N/A
<i>Location Address:</i>	1810-12 Bank St.
<i>License Type:</i>	Class "D" Beer, Wine and Liquor
<i>Is the establishment open and operating in a safe and sanitary manner? (If not open, not in comments - CLOSED or NOT OPERATING)</i>	Yes
<i>Is the location within 300 feet of Church and/or School?</i>	No
<i>Date Posted?</i>	5/26/2017
<i>Date Removed?</i>	
<i>Are there any other licensed establishments within a two block radius?</i>	Yes

*Other licensed locations - Describe/Note:*

See attached map

*Comments and Follow-up Items(s) (please note any issues or concerns about the location):*

Application filed to request outdoor table service.

*Insert Photo of Sign and location:*



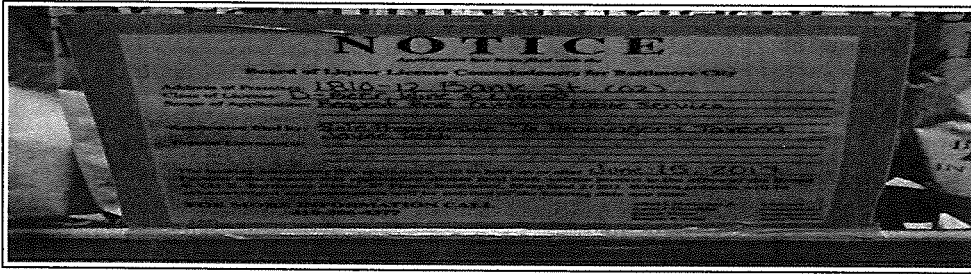

Inspector Name		Date and Time	
<input type="text" value="i:0#.w/baltimore\andy.perez"/>		<input type="text" value="6/7/2017"/>	<input type="text" value="10:10:14 AM"/>
Name of Licensee (if present)			
<input type="text"/>			
<input type="text"/>			

**Board of Liquor License Commissioners**

For Baltimore City  
 231 E. Baltimore Street, 6<sup>th</sup> Floor  
 Baltimore, Maryland, 21202-3258

**POSTING SIGNS REPORT**

<i>Applicant(s) Name:</i>	Jayne Irvin Vieth
<i>Address of Premises:</i>	1810-12 Bank St.
<i>Inspector:</i>	i:0#w/baltimore\andy.perez
<i>Date Posted:</i>	5/26/2017
<i>Time Posted:</i>	1:00 PM
<i>Date Rechecked:</i>	6/6/2017
<i>Time Rechecked:</i>	2:00 PM
<i>Manager or Owner when sign posted:</i>	

*Summary on location of sign posted:*

Sign posted on front window.

*Summary on location of sign rechecked:*

Sign remained as posted for the required 10 days period.

*Insert Photo of Sign and location:*



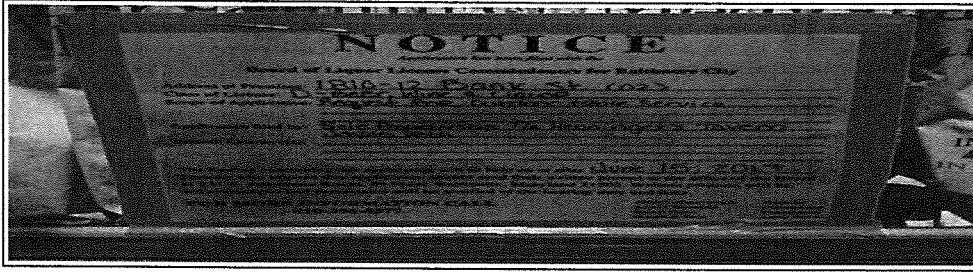

# BLLC Routine Inspection

*Licensee Information*

Address: 1810-12 BANK STREET 21231

Trade Name: HENNINGER'S TAVERN

Corporation Name: N/A

Type of License: Class "D" Beer, Wine and Liquor

Date/Time of Inspection: 2/8/2017

11:51:37 AM

Manager/Licensee: Ms. Vieth

*Open/Closed Status*

Open/Closed: Open

Closed Date:

*External Appearance*

Clean and Free of Debris: Satisfactory

*Internal Appearance*

Location of Bar: Front

Shape of Bar: Straight

Condition of Bar Area/Floors: Satisfactory

Hot Water: Yes

Disinfectant Solution: Yes

Three Compartment/Washer: Yes

*Package Goods/BD7 Checklist*

Bulletproof Partitioning: N/A

Separate Pkg. Goods Dept.: N/A

Separate Pkg. Goods Store: N/A

Bar/Tavern Open and Operating: N/A

Selling Household/Grocery: N/A



Dining Area

Capacity:

Location of Dining Area:

Condition of Dining Area/Floors:

Sanitation:

Menu:

Business Records

Traders License:

Alcohol Awareness Certification Date Issued:

Employee Records:

Alcohol Beverage Information Invoice Numbers and Date:

Kitchen

Inspector Comments:

Restroom

Inspector Comments:

Public Safety

Exits Marked, Unobstructed:

Fire Capacity:

Outdoor Seating Capacity:

Adult Entertainment - If Applicable

License is Valid:

Dancers Present 18 and older:

Cleanliness of Dressing Room: N/A

Ancillary Services

Live Entertainment (Describe): NO

Outdoor Table Service Yes

Violations

Violation Issued: No

Violations Noted:

Wrap-Up

Instructions Given to Licensee:

Inspector's Comments:

Photo Taken:

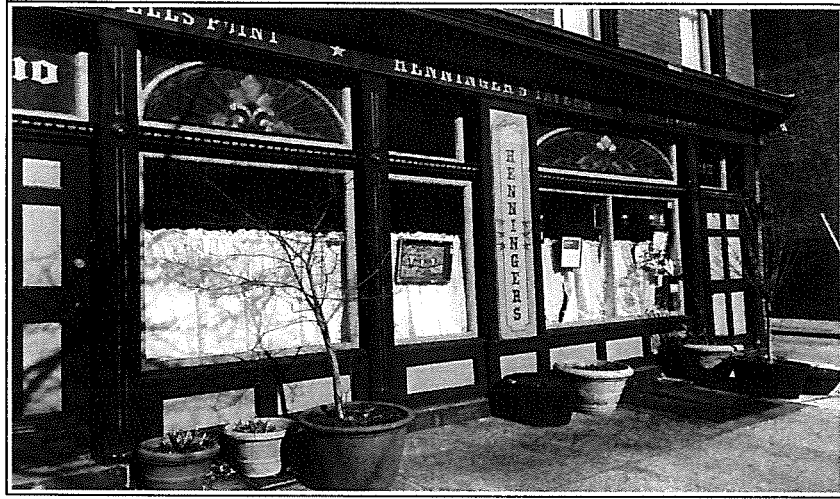

Owner Email:

Submitted by Inspector

# Certificate of Occupancy

THIS WRITTEN INSTRUMENT, WHEN PROPERLY VALIDATED, CONSTITUTES AUTHORITY FOR DOING OR RECEIVING THE THINGS INDICATED BY THE FEES OR CHARGES SHOWN IN THE APPROPRIATE SPACES BELOW. ANY AND ALL THINGS TO BE DONE OR RECEIVED UNDER THIS WRITTEN INSTRUMENT SHALL BE DONE OR RECEIVED IN STRICT COMPLIANCE WITH THE APPLICATION HERETOFORE FILED IN THIS DEPARTMENT FOR THE AUTHORITY CONTAINED HEREIN, INCLUDING ANY AND ALL APPROVED DRAWINGS AND OTHER DATA OR INFORMATION ATTACHED THERETO, AND SUBJECT TO ANY AND ALL LAWS, ORDINANCES, RULES AND REGULATIONS IN EFFECT IN THE CITY OF BALTIMORE AND THE STATE OF MARYLAND. WARNING: IT IS UNLAWFUL TO WORK BETWEEN THE HOURS OF 7:00 PM AND 7:00 AM WITHIN 300 FEET OF A DWELLING.

WARNING: IT IS UNLAWFUL TO CONCEAL ANY WORK UNTIL INSPECTED AND APPROVED BY THIS DEPARTMENT.

WARD	SEC.	BLOCK	LOT	ISSUE DATE	DISTRICT
02	02	1763	024	9/29/11	201

PROPERTY ADDRESS: 1810-1812 BANK ST

OWNER: JAYNE B VIETH ADDR: 1911 BANK ST BALTIMORE MD  
LESSEE: ADDR:

LAND USE CODES 5817 0000 0000 0000

(USE)CHANGE USE OF PREMISES FORM A TAVERN TO A RESTAURANT WITH OUTDOOR TABLE SERVICE. 3 TABLES WITH TOTAL OF 12 SEATS AS PER BMZA2010-289 APPROVED ON 08/17/10

1001-000000-2600-159600-400560 PER. INSP.	1001-000000-2600-158009-400480 MISC.	1001-000000-2600-158009-400480 CH. USE	1001-000000-2600-158301-400490 NEW BLDG.	1001-000000-2600-158302-400490 ADDITIONS	
		45.00			
1001-000000-2600-158302-400490 ALTERATIONS	1001-000000-2600-158304-400490 REPAIRS	1001-000000-2600-158304-400490 MISC. CONST.	1001-000000-2600-158800-400500 ELECT.	1001-000000-2600-158901-400510 HYDRONIC/STEAM HEAT	
1001-000000-2600-158902-400510 DISTRIB/EXH	1001-000000-2600-158902-400510 AIR COND.	1001-000000-2600-158902-400510 DISP. TANKS	1001-000000-2600-158905-400510 FIRE	1001-000000-2600-158906-400510 FUEL-BURNING EQUIPMENT	
1001-000000-2600-159300-400530 ELEVATOR	1001-000000-2600-159000-400520 PLUMBING	1001-000000-2600-159000-400520 S & E CONTROL	1001-000000-3700-508801-401811 CHAP	1001-000000-1500-102800-400230 TAX	3.00
1001-000000-2600-158306-400490 RAZING	1001-000000-2600-159400-400540 FILING FEE	1001-000000-2600-159400-400540 LOW VOLTAGE/TELECOMMUNICATIONS	1001-000000-2600-158009-400480 PENALTY	TOTAL FEES	98.00
	0.00	50.00			

THE AUTHORITY CONTAINED HEREIN MAY NOT BE VALIDLY EXERCISED UNTIL AND AFTER ALL OF THE FEES APPEARING HEREON HAVE BEEN PAID AND EVIDENCE THEREOF APPEARS IN THIS SPACE.



*Michael Braverman*  
MICHAEL BRAVERMAN  
BUILDING OFFICIAL

Please be advised that there is a presumption of lead-based paint in properties constructed prior to 1950. Protect workers and tenants by using the lead-safe work practices found in the Code of Maryland Regulations Section 26.02.07.

THE AUTHORITY CONTAINED HEREIN DOES NOT AUTHORIZE THE PERFORMANCE OF ANY WORK IN, ON UNDER OR OVER ANY STREET, HIGHWAY, ALLEY SIDEWALK OR ANY OTHER PUBLIC WAY, UNLESS PERMISSION TO DO SO HAS BEEN FIRST SECURED FROM THE PROPER AUTHORITY.

From: **Jeff May** landuse@upperfellspoint.org  
Subject: Letter re: Outdoor Seating  
Date: May 19, 2017 at 6:26 PM  
To: vieth\_kenny@comcast.net



Kenny,

Attached is a letter from UFPIA supporting Henninger's Outdoor seating.

Please let me know if it meets your needs.

I have not sent this to the commissioners yet. Will you submit it with your application?

Good Luck!

Jeff



*the*  
**UPPER FELL'S POINT**  
*Improvement Association/Asociación de Mejoramiento*  
Upper Fells Point, Baltimore, MD 21202



Board of Liquor License Commissioners for Baltimore City  
231 E. Baltimore Street, 6th Floor  
Baltimore, MD 21202

Re: Henninger's Tavern, 1812 Bank Street, Baltimore, MD 21231

Commissioners:

With respect to Henninger's Tavern, the Upper Fells Point Improvement Association (UFPIA) considers this establishment to be a model neighbor and an invaluable community asset. Jayne and Kenneth Vieth run Henninger's in a manner which is beyond reproach. Furthermore, the Association considers outdoor seating is a valuable community amenity. The seating will contribute to public safety by keeping "eyes on the street" while also contributing to the social life of the community.

APPROVED BY THE UFPIA BOARD

Jeffrey B. May  
Land Use Chair  
Upper Fells Point Improvement Association

cc: Councilman Zeke Cohen  
Kenneth Vieth, Henninger's Tavern

**June 15, 2017**

**Licensee(s):** Corey LaPrade  
Laprade Lounge at 148, LLC, T/a Tavern at 148  
148 S. East Avenue 21224

**Class:** "BD7" Beer, Wine & Liquor License

Request for a hardship extension.

**Board's Information:**

(a) **Ownership Breakdown:** (1) Corey LaPrade (100%)

(b) **Corporate Standing:** Laprade Lounge at 148, LLC is a MD LLC and as of 5/23/2017 is not in good standing.

(c) **Timeline of request:** On 5/4/2017 staff received hardship letter request from the licensee for the license. According to request the establishment was closed as of 1/8/2017. The first 180 days of the hardship extension runs until 7/7/2017. As the hardship letter was filed within 180 days, this hardship extension request meets the requirements of Alc. Bev. Art. 12-2202 as it was filed within the 180 day period (on or before July 7, 2017).

**Board's Decision:**

LAW OFFICES  
**MELVIN J. KODENSKI, ESQUIRE**  
19 E. FAYETTE STREET  
SUITE 400  
BALTIMORE, MARYLAND 21202

TELEPHONE (410-685-5100)  
FACSIMILE (410-685-5825)  
[melvinjkodenski@hotmail.com](mailto:melvinjkodenski@hotmail.com)

May 4, 2017

Liquor Board Commissioners  
231 E. Baltimore Street – 6<sup>th</sup> Floor  
Baltimore, Maryland 21202  
Attn: Thomas Akras

Re: 148 S. East Avenue

Dear Mr. Akras:

The application for transfer of license from 148, LLC to Harbor East Parcel-D Rooftop Dining LLC has been withdrawn.

At this time I would like to request a hardship extension on behalf of the Licensee, as they were counting on this transfer to the sum and extent that a hardship extension is necessary. This is the last asset that the LLC has to dispose of and it would cause a financial hardship not to be able to sell same and there is a possible other application to be filed shortly.

Thank you for your kind cooperation.

Very truly yours,

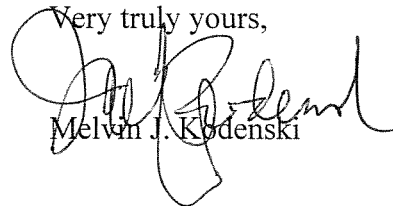

Melvin J. Kodenski

MJK:dl  
Enclosure  
cc: Corey LaPrade

MJK\3085

RECEIVED  
MAY 10 10:26 AM '17

RECEIVED

LAW OFFICES  
**MELVIN J. KODENSKI, ESQUIRE**  
19 E. FAYETTE STREET  
SUITE 400  
BALTIMORE, MARYLAND 21202

TELEPHONE (410-685-5100)  
FACSIMILE (410-685-5825)  
[melvinjkodenski@hotmail.com](mailto:melvinjkodenski@hotmail.com)

May 17, 2017

Liquor Board Commissioners  
231 E. Baltimore Street – 6<sup>th</sup> Floor  
Baltimore, Maryland 21202  
Attn: Thomas Akras

Re: 148 S. East Avenue

Dear Mr. Akras:

There was a question on the hardship extension as to when the last time the place was open and I received confirmation from my client that January 7, 2017 was the last open day and he paid sales tax in the month of February.

Kindly add this letter to the file.

Thank you for your kind cooperation.

Very truly yours,



Melvin J. Kodenski

MJK:dl  
MJK\3085

RECEIVED  
MAY 22 AM 9:25  
COMMISSIONERS OF LIQUOR





## Liquor Board System

Version 1.0

Annual-Renewal | License-Transfer | One-Day | Add New License | Query | Help

### License Detail

[Close the License](#)

[Print License](#)

[Print Renewal Letter](#)

[<< Go Back](#)

#### License Info

License Num: **LBD7 376**

Cert Num: **1092**

Fee: **\$1,320.00** Status: **Renewed**

License Date: 5/1/2017

License Year: 2017

CR Number: 02965547

Payment Date: 05-10-17

2016 - 2017 TPP Paid

2017 Trader's License  [Update Info](#)

[Click to Start License Renewal](#)

### Add Adult Entertainment License

[Add New Adult Entertainment License](#)

#### Location

Corp Name: **LAPRADE LOUNGE AT 148, LLC**

Trade Name: **TAVERN AT 148**

Zone Code: 11

Phone: 410-342-5845

Block Num: 148

City: BALTIMORE

Street: EAST AVENUE SOUTH

State: MD

Zip: 21224

CR Number: 02965547

Portion of Business Used:

USE THE FIRST FLOOR AS A TAVERN NEW OPERATOR BASEMENT ACCESSORY STORAGE,  
CLASS 3 NONCONFORMING USE REMAINS NEVER CLOSED ZONED R-8

Restriction:

[Edit the License Location Info](#)

[Alternate Mailing Address](#)

#### License Owners

First Name	Last Name	Street	City	State	Zip	Action	Change Owner
COREY	LAPRADE	208 S. EAST AVENUE	BALTIMORE	MD	21224	<a href="#">Edit</a>	<a href="#">Remove Owner</a>

#### Comments

Date	Comment	Action

03/22/2017	*****RELEASED STATE HOLD..... /mb	Delete
01/18/2017	*****STATE OF MD TAX HOLD, letter sent to Licensee on January 17, 2017.***** /sb	Delete
11/04/2016	PAID \$100.00 for Hearing dated 10/27/16 for Hardship Extension. Invoice #104398.../sb	Delete
10/31/2016	10/28/16 - Sent Fax to Mel Kodenski office stating that Licensee owes \$100.00 for hearing administrative fee.... /sb	Delete
10/28/2016	10/27/2016- Public hearing re: request for hardship extension, and request to reopen after being closed for more than 90 days- APPROVED	Delete
08/18/2016	Submitted "Personal Property Tax Clearance".... /sb	Delete
08/16/2016	Mr. Akras informed Ms Robinson that Mr Lapade needs to submit copies of invoice from the distributor and not a print out of same day transactions. Mr. Akras also stated that Mr. Lapae needs to submit an affidavit basically telling the board that he cease the sell of alcohol but he has been operating Ms. Robinson tried to call Mr Lapade about the additional information but was not able to leave voicemail [REDACTED]....per t/a	Delete
08/16/2016	License owner ( Corey Lapade) paid for the license fee for 2016-2017 in \$1320.00 (invoice #103953) Mr. Lapade submitted proof that business has been opening and operating since license has been expired 2. letter of good standing . Licensee did not submit 2016 trader's license we were unable to release the license today 08/16/2016.....k/r	Delete
08/12/2016	Manger of business (Chris) came in to pay the 2016 License Fee. It was told to client that in order to release the 2016 License the following documents need to be received: 1. Bring letter of good standing 2. License fee of the amount \$1320.00 (made out to Director of Finance) 3. Proof that business has been opening in operating during time of expired license date .....per t.a/ k.r	Delete
07/26/2016	07/25/16 - Mailed letter to Licensee about "Personal Property Tax Owed to the City of Baltimore".... /sb	Delete
05/23/2016	Client bought in letter of good standing but was not able to make a payment today.....k/r check folder for letter	Delete
05/09/2016	must provide certificate of good standing--hold license. ND	Delete
06/08/2015	Alcohol Awareness expires 03/10/18 (Charles H. Thrasher)	Delete
01/30/2015	State of MD Tax Hold, letter sent to merchant on January 23, 2015.	Delete
01/28/2014	1/09/2014 Public Hearing re: Application to transfer ownership. Board APPROVED transfer	Delete

[ Print History (Print Card) ]

License num: LBD7 376                      Address: 148 EAST AVENUE SOUTH  
 Trade Name: TAVERN AT 148

Comment: \_\_\_\_\_

[ Add Comment ]

**Hold Info**



## Business Entity Search, Certificate of Status & Document Order

LAPRADE LOUNGE AT 148 LLC: W15558208

[Order Documents](#)

[General Information](#) [Filing History](#) [Personal Property](#)

### General Information

**Department ID Number:**  
W15558208

**Business Name:**  
LAPRADE LOUNGE AT 148 LLC

**Principal Office:**  
208 S. EAST AVE.  
BALTIMORE MD 21224

**Resident Agent:**  
COREY LAPRADE  
208 S. EAST AVE.  
BALTIMORE MD 21224

**Status:**  
REVIVED

**Good Standing:**  
THIS BUSINESS IS NOT IN GOOD STANDING  
» [Order Certificate of Status](#)

**Reason(s) for Status:**  
RETURN DUE  
What does it mean if a business entity is not in good standing or forfeited?

**Business Type:**  
DOMESTIC LLC

**Business Code:**  
ENTITIES OTHER THAN CORPORATIONS

**Date of Formation/ Registration:**  
11/22/2013

**State of Formation:**  
MD

**Stock Status:**  
N/A

**Close Status:**  
N/A

[New Search](#) [Order Documents](#)

Your Progress

Business Entity Search

**➔ General Information**

Document Order

June 15, 2017

**Licensee(s):** Ronald Persaud  
MVP Entertainment, LLC T/a Club 347  
347 N. Calvert Street 21202

**Class:** "BD7" Beer, Wine & Liquor License

Request for a hardship extension.

**Board's Information:**

(a) **Ownership Breakdown:** (1) Ronald Persaud (100%).

(b) **Corporate Standing:** MVP Entertainment, LLC is a MD LLC and as of 5/17/2017 is in good standing.

(c) **Timeline of request:** On 5/2/2017 staff received a hardship letter request from the attorney for the licensee for the license. According to the request the establishment closed as of 12/20/2016. The first 180 days of the hardship extension runs until 6/18/2017. As the hardship letter was filed within 180 days, this hardship extension request meets the requirements of Alc. Bev. Art. 12-2202 as it was filed within the 180 day period (on or before June 18, 2017).

**Board's Decision:**

LAW OFFICES  
**MELVIN J. KODENSKI, ESQUIRE**  
19 E. FAYETTE STREET  
SUITE 400  
BALTIMORE, MARYLAND 21202

TELEPHONE (410-685-5100)  
FACSIMILE (410-685-5825)  
[melvinjkodenski@hotmail.com](mailto:melvinjkodenski@hotmail.com)

May 1, 2017

Thomas Akras  
Douglas Paige  
Baltimore City Liquor Board  
231 E. Baltimore Street – 6<sup>th</sup> Floor  
Baltimore, Maryland 21202

Re: license: MVP Entertainment, LLC, t/a Club 347  
347 N. Calvert Street

Gentlemen:

On behalf of MVP Entertainment, LLC, t/a Club 347, we would like to request a hardship extension for the following reasons.

Mercy Medical Center purchased the real property at 347 N. Calvert Street and did not wish to lease the property to the licensee (i.e. use the property as a tavern) and subsequently, the licensee had to find a new location. The business closed on December 20, 2016.

MVP Entertainment, LLC is submitting a transfer of location application with this letter. The license is being moved to 3601 Pulaski Highway and it will take some time before the hearing is held and the license can be transferred to the new location; therefore, we are requesting a hardship extension.

I am enclosing a check of \$100.00 for the hardship fee.

Thank you for your kind cooperation.

Very truly yours,

  
Melvin J. Kodenski

MJK\ep  
MJK\4126  
Enclosures

RECEIVED  
BALTIMORE CITY LIQUOR BOARD  
LICENSING COMMISSIONERS

MAY - 2 PM 2: 25

RECEIVED



# Liquor Board System

Version 1.0

Annual-Renewal ▾ | License-Transfer ▾ | One-Day ▾ | Add New License ▾ | Query ▾ | Help ▾

## License Detail

### License Info

License Num: **LBD7 409**      Cert Num: **1158**      Fee: **\$1,320.00**      Status: **Renewed**  
 License Date: 5/1/2017      License Year: 2017  
 CR Number: 11781606  
 Payment Date: 05-02-17

2016 - 2017 TPP Paid   
 2017 Trader's License

## Add Adult Entertainment License

### Location

Corp Name: **MVP ENTERTAINMENT, LLC**  
 Trade Name: **CLUB 347**  
 Zone Code: 25  
 Phone: 410-547-0414

Block Num: 347      Street: CALVERT STREET NORTH  
 City: BALTIMORE      State: MD      Zip: 21202

CR Number: 11781606

Portion of Business Used:  
 FIRST & SECOND FLOORS FOR BUSINESS & BASEMENT FOR STORAGE

Restriction:  
 APPROVED FOR LIVE ENTERTAINMENT

### License Owners

First Name	Last Name	Street	City	State	Zip	Action	Change Owner
RONALD	PERSAUD	2009-I WOODLAWN DRIVE	BALTIMORE	MD	21207	<input type="button" value="Edit"/>	<input type="button" value="Remove Owner"/>

### Comments

Date	Comment	Action

04/27/2017	Contacted Ronald Persaud and informed him that he needs to file a transfer application or a hardship within 180 days of 12/6/2016 or the license will expire. TRA	Delete
06/07/2016	6/2/2016 -PROTEST OF RENEWAL 2016- PROTEST WITHDRAWN WITH TERMS (3-0 VOTE) TO RENEW LICENSE	Delete
03/16/2016	reviewed 2016 renewal application-LLC is not in good standing-must submit certificate of good standing before license is released. ND	Delete
02/09/2015	2/2/2015 Alcohol Awareness Certified John S Murray expires 2/2/2019	Delete
09/29/2004	09/09/04 Public Hearing re: Violation of rule 4.10(a)and rule 4.18.DECISION: RULE 4.10(a) GUILTY \$100 OR 1 DAYS AND RULE 4.18 DISMISSED + \$125 ADM.FEE. LICENSEE PAID \$125 ADM.FEE AND TOOK 1 DAY SUSPENSION.	Delete
09/10/2004	09/09/04 FINE PAID IN FULL FOR 5/20/04 HEARING (2466)	Delete
05/21/2004	05/20/04 Public Hearing re: Violation of rules 4.05(a),4.05(b),Art.2B,Sec.11-304(d)(2), rule 3.02 and rule 4.16. (1/11/04) DECISION: RULE 4.05(a)GUILTY \$500 OR 5 DAYS/SUSPENDED \$300-FINE \$200 OR 2 DAYS,RULE 4.05(b)DISMISSED,aRT.2B,SEC.11-304(D)(2)GUILTY \$500 OR 5 DAYSSUSPENDED \$300-FINE \$200 OR 2 DAYS,RULE 3.02 GUILTY \$500 OR 5 DAYS,AND RULE 4.16 DISMISSED. FINE \$900 OR 9 DAYS + \$125 ADM.FEE = \$1025	Delete

Print History (Print Card)

License num: LBD7 409  
Trade Name: CLUB 347

Address: 347 CALVERT STREET NORTH

Comment:

Add Comment

Hold Info

Powered by:



## Business Entity Search, Certificate of Status & Document Order

MVP ENTERTAINMENT, LLC: W10178127

[General Information](#)   [Filing History](#)   [Personal Property](#)

### General Information

**Department ID Number:**  
W10178127

**Business Name:**  
MVP ENTERTAINMENT, LLC

**Principal Office:**  
355 N. CALVERT STREET  
BALTIMORE MD 21202

**Resident Agent:**  
RONALD PERSAUD  
355 N. CALVERT STREET  
BALTIMORE MD 21202

**Status:**  
ACTIVE

**Good Standing:**  
THIS BUSINESS IS IN GOOD STANDING  
» [Order Certificate of Status](#)

**Business Type:**  
DOMESTIC LLC

**Business Code:**  
ENTITIES OTHER THAN CORPORATIONS

**Date of Formation/ Registration:**  
07/19/2004

**State of Formation:**  
MD

**Stock Status:**  
N/A

**Close Status:**  
N/A

🔍 [New Search](#)

[Your Progress](#)

[Business Entity Search](#)

➔ [General Information](#)

[Document Order](#)

[Contact Information](#)



June 15, 2017

**Licensee(s):** Michael Buenger and Carolyn Lissau  
Diamond Jim, Inc. T/a Diamond Lounge  
415 E. Baltimore Street 21202

**Class:** "BD7" Beer, Wine & Liquor License and Class "AE" Adult Entertainment License

Request for a hardship extension.

**Board's Information:**

(a) **Ownership Breakdown:** (1) Michael Buenger (90%); and (2) Carolyn Lissau (10%).

(b) **Corporate Standing:** Diamond Jim, Inc. is a MD Corporation and as of 5/17/2017 is in good standing.

(c) **Timeline of request:** On 5/1/2017 staff received a hardship letter request from the attorney for the licensee for the license. According to the letter from attorney the establishment closed as of 2/15/2017. The first 180 days of the hardship extension runs until 8/14/2017. As the hardship letter was filed within 180 days, this hardship extension request meets the requirements of Alc. Bev. Art. 12-2202 as it was filed within the 180 day period (on or before August 14, 2017).

**Board's Decision:**

LAW OFFICES  
**MELVIN J. KODENSKI, ESQUIRE**  
19 E. FAYETTE STREET  
SUITE 400  
BALTIMORE, MARYLAND 21202

TELEPHONE (410-685-5100)  
FACSIMILE (410-685-5825)  
[melvinjkodenski@hotmail.com](mailto:melvinjkodenski@hotmail.com)

May 10, 2017

Douglas Paige  
Thomas Akras  
Baltimore City Liquor Board  
231 E. Baltimore Street – 6<sup>th</sup> Floor  
Baltimore, Maryland 21202

Re: Diamond Jim, Inc.  
415 ½ E. Baltimore Street

Dear Gentlemen:

On behalf of Diamond Jim, Inc., we would request a hardship extension, which is the last remaining asset of Diamond Jim, Inc. There is a possible sale pending, however, in an abundance of caution, we would like to request a hardship extension for both the liquor license and adult entertainment license.

I enclose a check for \$100.00 for payment of the hearing.

Thank you for your kind cooperation.

Very truly yours,

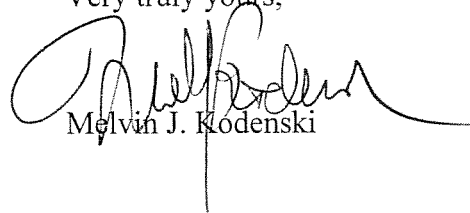

Melvin J. Kodenski

MJK:dl

Enclosure

cc: Michael Buenger

MJK\3934

RECEIVED  
MAY 10 10 46 AM '17  
BOARD OF LIQUOR  
LICENSING COMMISSIONERS

MAY 10 10 46 AM '17

RECEIVED

LAW OFFICES  
**MELVIN J. KODENSKI, ESQUIRE**  
19 E. FAYETTE STREET  
SUITE 400  
BALTIMORE, MARYLAND 21202

TELEPHONE (410-685-5100)  
FACSIMILE (410-685-5825)  
[melvinjkodenski@hotmail.com](mailto:melvinjkodenski@hotmail.com)

May 18, 2017

Thomas Akras  
Staci Russell  
Baltimore City Liquor Board  
231 E. Baltimore Street – 6<sup>th</sup> Floor  
Baltimore, Maryland 21202

Re: Diamond Jim, Inc.  
415 ½ E. Baltimore Street

Dear Mr. Akras & Ms. Russell:

I have been advised that you needed the date of the last time Diamond Jim, Inc. was open, as we had filed for a hardship extension on May 10, 2017.

Mr. Buenger has advised that the last day they were open was January 17, 2017, as indicated on the renewal application, which should be in the file, as part of his record.

I hope this brings everything up-to-date.

Very truly yours,



Melvin J. Kodenski

MJK:dl  
Enclosure  
cc: Michael Buenger  
MJK\3934

BOARD OF LIQUOR  
LICENSING COMMISSIONERS

7 MAY 18 AM 9:44

RECEIVED



## Liquor Board System

Version 1.0

Annual-Renewal ▾ | License-Transfer ▾ | One-Day ▾ | Add New License ▾ | Query ▾ | Help ▾

### License Detail





#### License Info

License Num: **LBD7 386**Cert Num: **1116**Fee: **\$1,320.00** Status: **Renewed**

License Date: 5/1/2017

License Year: 2017

CR Number: 07580927

Payment Date: 04-26-17

2016 - 2017 TPP Paid 2017 Trader's License 



### Add Adult Entertainment License

#### Location

Corp Name: **DIAMOND JIM, INC.**Trade Name: **DIAMOND LOUNGE**

Zone Code: 26

Phone: 410-685-4651

Block Num: 415

City: BALTIMORE

Street: BALTIMORE STREET EAST

State: MD

Zip: 21202

CR Number: 07580927

Portion of Business Used:

BASEMENT FOR BUSINESS

Restriction:

BILL BOND BARRED FROM PREMISES IN ANY CAPACITY.



#### License Owners

First Name	Last Name	Street	City	State	Zip	Action	Change Owner
MICHAEL J	BUENGER	2 FAWN DRIVE	SHREWSBURY	PA	17361	<input type="button" value="Edit"/>	<input type="button" value="Remove Owner"/>
CAROLYN L.	LISSAU	1210 FREDERICK ROAD	BALTIMORE	MD	21228	<input type="button" value="Edit"/>	<input type="button" value="Remove Owner"/>

#### Comments

Date	Comment	Action
05/04/2017	Spoke with Attorney Mel Kodenski on this matter. He stated that his client will be submitting a hardship extension request letter for this property. It closed sometime between Jan-Mar of 2017. TRA	Delete
12/28/2016	07-06-16 - Submitted Fire Permit... /sb	Delete
12/14/2015	PAID \$625.00 for Hearing dated; November 19, 2015, Invoice #100139.... /sb	Delete
11/03/2015	3/12/15 VIOLATION HEARING RE: Violation of Rule 3.12 Violation of Rule 4.18 Violation of Adult Entertainment Rule 9 Violation of Adult Entertainment Rule 14 GUILTY--\$500 FINE +\$125 ADMIN FEE	Delete
03/18/2015	3/12/2015 Liquor Board fine is PAID IN FULL	Delete
01/23/2009	01/21/09 \$100 COMPLIANCE CONF FEE PAID IN FULL #65634	Delete

[Print History \(Print Card\)](#)

License num: LBD7 386

Address: 415 BALTIMORE STREET EAST

Trade Name: DIAMOND LOUNGE

Comment:

[Add Comment](#)

**Hold Info**

Powered by:



## Business Entity Search, Certificate of Status & Document Order

DIAMOND JIM, INC.: D04236840

[Order Documents](#)

[General Information](#) [Filing History](#) [Personal Property](#)

### General Information

**Department ID Number:**  
D04236840

**Business Name:**  
DIAMOND JIM, INC.

**Principal Office:**  
415 1/2 E BALTIMORE ST  
BALTIMORE MD 21202

**Resident Agent:**  
MICHAEL BUENGER  
735 WILTON FARM DR  
CATONSVILLE MD 21228

**Status:**  
INCORPORATED

**Good Standing:**  
THIS BUSINESS IS IN GOOD STANDING  
» [Order Certificate of Status](#)

**Business Type:**  
CORPORATION

**Business Code:**  
ORDINARY BUSINESS - STOCK

**Date of Formation/ Registration:**  
10/02/1995

**State of Formation:**  
MD

**Stock Status:**  
STOCK

**Close Status:**  
YES

[New Search](#) [Order Documents](#)

Your Progress

Business Entity Search

➔ **General Information**

Document Order

Contact Information

June 15, 2017

**Licensee(s):** Edward Foreman, Brian Foreman, and Daniel Inouye  
JBE Corporation, T/a Parkville Bowling Lanes  
7603-09 Harford Road 21234

**Class:** ""D" Beer & Wine License

Request for a hardship extension.

**Board's Information:**

(a) **Ownership Breakdown:** (1) Edward Foreman (50%); (2) Brian Foreman (50%); and (3) Daniel Inouye (0%).

(b) **Corporate Standing:** JBE Corporation is a MD LLC and as of 5/17/2017 is in good standing.

(c) **Timeline of request:** On 4/3/2017 staff received a hardship letter request from the attorney for the licensee for the license. According to the letter from the attorney the establishment closed as of 10/19/2016. The first 180 days of the hardship extension runs until 4/17/2017. As the hardship letter was filed within 180 days, this hardship extension request meets the requirements of Alc. Bev. Art. 12-2202 as it was filed within the 180 day period (on or before April 17, 2017).

**Board's Decision:**

LAW OFFICES  
**MELVIN J. KODENSKI, ESQUIRE**  
19 E. FAYETTE STREET  
SUITE 400  
BALTIMORE, MARYLAND 21202

TELEPHONE (410-685-5100)  
FACSIMILE (410-685-5825)  
[melvinjkodenski@hotmail.com](mailto:melvinjkodenski@hotmail.com)

April 1, 2017

Thomas Akras  
Douglas Paige  
Baltimore City Liquor Board  
231 E. Baltimore Street – 6<sup>th</sup> Floor  
Baltimore, Maryland 21202

Re: 7603-09 Harford Road  
JEB Corporation t/a Parkville Bowling Lanes

Gentlemen:

On behalf of JEB Corporation t/a Parkville Bowling Lanes and the landlord, Parkville Shopping Center, LLC, we would like to request a hardship extension, as there was some damage to the bowling lanes and there is a possible situation where the license may be transferred to the Landlord. The hardship would be getting the location into proper shape for re-opening.

The last date the place was open for business was October 19, 2016 and I enclose a copy of the Statement from the Operator for your files.

Thank you for your kind cooperation.

Very truly yours,

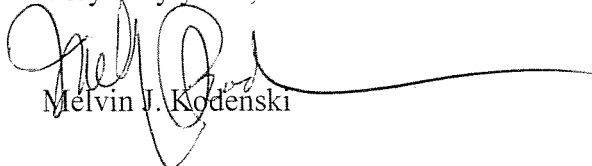
  
Melvin J. Kodenski

MJK:dl  
Enclosure  
MJK\4099

RECEIVED  
017 MAR 31 AM 10:34  
BOARD OF LIQUOR  
LICENSING COMMISSIONERS



STATEMENT

I, Edward Foreman, Operator of Parkville Bowling Lanes, hereby solemnly state and affirm under the penalties of perjury that the last date of business for Parkville Bowling Lanes was Oct. 19, 2016.

Edward Foreman

Operator



## Liquor Board System

Version 1.0

Annual-Renewal ▾ | License-Transfer ▾ | One-Day ▾ | Add New License ▾ | Query ▾ | Help ▾

### License Detail





#### License Info

License Num: **WD 040**Cert Num: **1098**Fee: **\$165.00**Status: **Renewed**

License Date: 5/1/2017

License Year: 2017

CR Number: 03885996

Payment Date: \*\*\*\*

2016 - 2017 TPP Paid 2017 Trader's License 



### Add Adult Entertainment License

#### Location

Corp Name: **JBE CORP**Trade Name: **PARKVILLE BOWLING LANES**

Zone Code: 44

Phone: 410-444-6100

Block Num: 7603-09

Street: HARFORD ROAD

City: BALTIMORE

State: MD

Zip: 21234

CR Number: 03885996

Portion of Business Used:

50' FRONT PORTION OF BUILDING IN BASEMENT FOR BUSINESS

Restriction:



#### License Owners

First Name	Last Name	Street	City	State	Zip	Action	Change Owner
EDWARD	FOREMAN	6 DANDELION COURT	OWINGS MILLS	MD	21117	<input type="button" value="Edit"/>	<input type="button" value="Remove Owner"/>
BRIAN	FOREMAN	4800 CARMAN DRIVE	ELLCOTT CITY	MD	21043	<input type="button" value="Edit"/>	<input type="button" value="Remove Owner"/>
DANIEL TJ	INOUYE	3402 NORTHWAY DRIVE	BALTIMORE	MD	21234	<input type="button" value="Edit"/>	<input type="button" value="Remove Owner"/>

### Comments

Date	Comment	Action
01/17/2017	*****STATE OF MD TAX HOLD, letter sent to Licensee on January 17, 2017.***** /sb	<input type="button" value="Delete"/>

License num: WD 040                      Address: 7603-09 HARFORD ROAD  
Trade Name: PARKVILLE BOWLING LANES

Comment: \_\_\_\_\_

### Hold Info



Business Entity Search, Certificate of Status & Document Order

JBE CORP.: D02205656

Order Documents

General Information Filing History Personal Property

General Information

Department ID Number:  
D02205656

Business Name:  
JBE CORP.

Principal Office:  
7603 HARFORD ROAD  
BALTIMORE MD 21234

Resident Agent:  
EDWARD FOREMAN  
7603 HARFORD ROAD  
BALTIMORE MD 21234

Status:  
INCORPORATED

Good Standing:  
THIS BUSINESS IS IN GOOD STANDING  
» Order Certificate of Status

Business Type:  
CORPORATION

Business Code:  
ORDINARY BUSINESS - STOCK

Date of Formation/ Registration:  
09/24/1986

State of Formation:  
MD

Stock Status:  
STOCK

Close Status:  
UNKNOWN

New Search

Order Documents

Your Progress

Business Entity Search

**→ General Information**

Document Order

Contact Information

June 15, 2017

**Applicant(s):** Dimitris Spiliadis, Pauline Spiliadis, and Sotirios Spiliadis  
Olive Grove Catering, Inc., T/a Inn at the Black Olive  
803 S. Caroline Street 21231

**Class:** "B" Beer, Wine & Liquor License

Request for a hardship extension.

**Board's Information:**

(a) **Ownership Breakdown:** (1) Dimitris Spiliadis (33 1/3%); (2) Pauline Spiliadis (33 1/3 %); and (3) Sotirios Spiliadis (33 1/3%).

(b) **Corporate Standing:** Olive Grove Catering, Inc. is a MD Corporation and as of 5/17/2017 is in good standing.

(c) **Timeline of request:** On 4/21/2017 staff received a hardship letter request from the building owner. According to landlord the establishment closed as of 10/28/2016. The first 180 days of the hardship extension runs until 4/26/2017. As the hardship letter was filed within 180 days, this hardship extension request meets the requirements of Alc. Bev. Art. 12-2202 as it was filed within the 180 day period (on or before 4/26/2017).

**Board's Decision:**

April 21, 2017

Mr. Thomas R. Akras, ESQ.  
Deputy Executive Secretary  
Board of Liquor License Commissioners  
231E. Baltimore St.  
Baltimore, Maryland 21202

Dear Mr. Akras

Please find this letter as a request for a Hardship Extension regarding the Liquor License number LB 309 currently held by Olive Grove Catering, Inc. As owner of the building in which Olive Grove Catering, Inc. was the tenant, 803 South Caroline Street LLC, is seeking to have the license transferred to us in order to allow for use in the re-tenanting of the restaurant component of the property located at 803 South Caroline Street Baltimore MD 21231. Olive Grove Catering ceased operation at the property October 28<sup>th</sup> 2016.

We are requesting this extension in order to work through the transfer process which includes an existing personal property tax issue incurred by the current license holder.

Thank you in advance for the consideration in this matter and we look forward to your response.

Dan Baird  
Managing Member  
803 South Caroline Street LLC

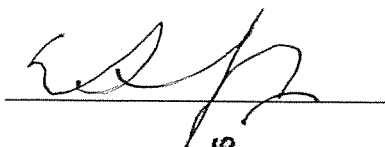

RECEIVED

APR 21 PM 1:52

BOARD OF LIQUOR  
LICENSING COMMISSIONERS



## Liquor Board System

Version 1.0

Annual-Renewal ▾ | License-Transfer ▾ | One-Day ▾ | Add New License ▾ | Query ▾ | Help ▾

### License Detail





#### License Info

License Num: **LB 286**Cert Num: **1086**Fee: **\$1,820.00** Status: **Renewed**

License Date: 5/1/2017

License Year: 2017

CR Number: 15446684

Payment Date: \*\*\*\*

2016 - 2017 TPP Paid 2017 Trader's License 



### Add Adult Entertainment License

#### Location

Corp Name: **OLIVE GROVE CATERING, INC.**Trade Name: **INN AT THE BLACK OLIVE**

Zone Code: 23

Phone: 410-276-7141

Block Num: 803

City: BALTIMORE

Street: CAROLINE STREET SOUTH

State: MD

Zip: 21231

CR Number: 15446684

Portion of Business Used:

USE FIRST FLOOR AS A MARKET/CAFE, SECOND THRU FOURTH FLOORS AS A HOTEL WITH  
FOUR ROOMS ON EACH FLOOR AND ON THE FIFTH FLOOR USE AS A RESTAURANT

Restriction:



#### License Owners

First Name	Last Name	Street	City	State	Zip	Action	Change Owner
DIMITRIS	SPILIADIS	716 S. BETHEL STREET	BALTIMORE	MD	21231	<input type="button" value="Edit"/>	<input type="button" value="Remove Owner"/>
PAULINE	SPILIADIS	1609 SHAKESPEARE STREET	BALTIMORE	MD	21231	<input type="button" value="Edit"/>	<input type="button" value="Remove Owner"/>
SOTIRIOS	SPILIADIS	1609 SHAKESPEARE STREET	BALTIMORE	MD	21231	<input type="button" value="Edit"/>	<input type="button" value="Remove Owner"/>

**Comments**

Date	Comment	Action
04/21/2017	4/21/17 Hardship letter received Invoice # 106524	Delete
12/02/2016	SUSPENSION NOTICE HAS BEEN ISSUED AND PLACED ON BUILDING UNTIL FURTHER NOTICE..... /sb	Delete
07/28/2016	07/28/16 - Mailed letter to Licensee about "Personal Property Tax Owed to the City of Baltimore".... /sb	Delete
04/29/2016	***** RELEASED STATE TAX HOLD ***** /sb	Delete
03/18/2016	*****STATE TAX HOLD - RENEWAL 2016-2017***** /sb	Delete
04/02/2015	RELEASED STATE OF MD TAX HOLD ON 04/01/15...../sb	Delete
02/03/2015	State of MD Tax Hold, letter sent to merchant on January 23, 2015.	Delete

[Print History \(Print Card\)](#)

License num: LB 286

Address: 803 CAROLINE STREET SOUTH

Trade Name: INN AT THE BLACK OLIVE

Comment:

[Add Comment](#)

**Hold Info**

Powered by:





## Business Entity Search, Certificate of Status & Document Order

OLIVE GROVE CATERING, INC.: D03981669

[Order Documents](#)

[General Information](#) [Filing History](#) [Personal Property](#)

### General Information

**Department ID Number:**

D03981669

**Business Name:**

OLIVE GROVE CATERING, INC.

**Principal Office:**

814 SOUTH BOND ST  
BALTIMORE MD 21231

**Resident Agent:**

DIMITRIS SPILIADIS  
814 SOUTH BOND STREET  
BALTIMORE MD 21231

**Status:**

REVIVED

**Good Standing:**

THIS BUSINESS IS IN GOOD STANDING  
» [Order Certificate of Status](#)

**Business Type:**

CORPORATION

**Business Code:**

ORDINARY BUSINESS - STOCK

**Date of Formation/ Registration:**

10/04/1994

**State of Formation:**

MD

**Stock Status:**

STOCK

**Close Status:**

NO CLOSE

[New Search](#)

[Order Documents](#)

Your Progress

Business Entity Search

**➔ General Information**

Document Order

Contact Information